

NOTES:

- 1.MATERIAL: BAR RECT.ALUMINUM TYPE 6061-T6 PER ASTM B221.
- 2.VIBRO-ETCH PART WITH DRAWING NUMBER WITH MIN..12 HIGH CHARACTERS IN ACCORDANCE WITH MIL-STD 130. LOCATE APPROX. AS SHOWN.

REVISION APPROVALS

REV	ECN NO.	DESCRIPTION	DATE	BY	CHK	DES	ENG	SUPV
A	-	INITIAL RELEASE	-	-	-	-	-	-

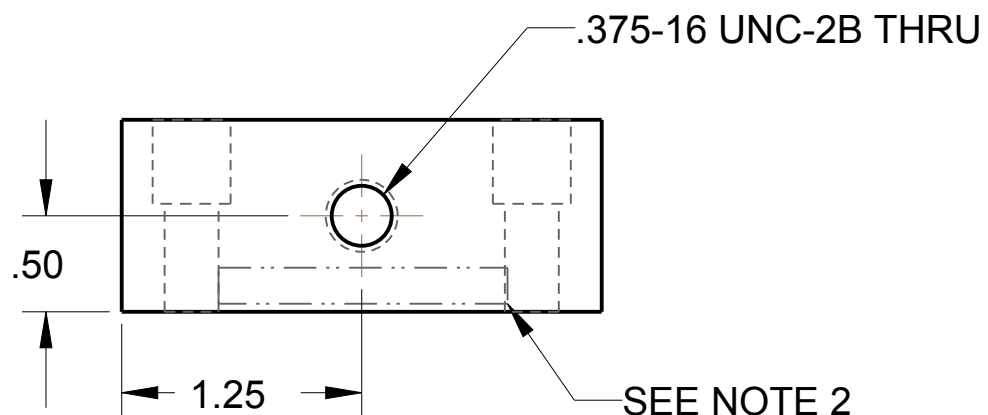
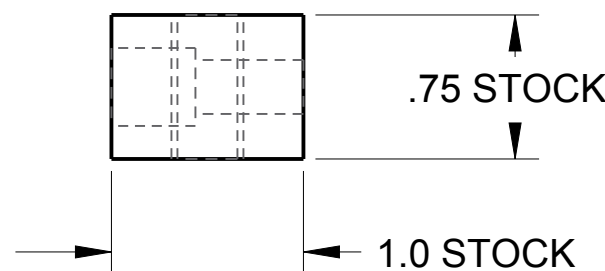
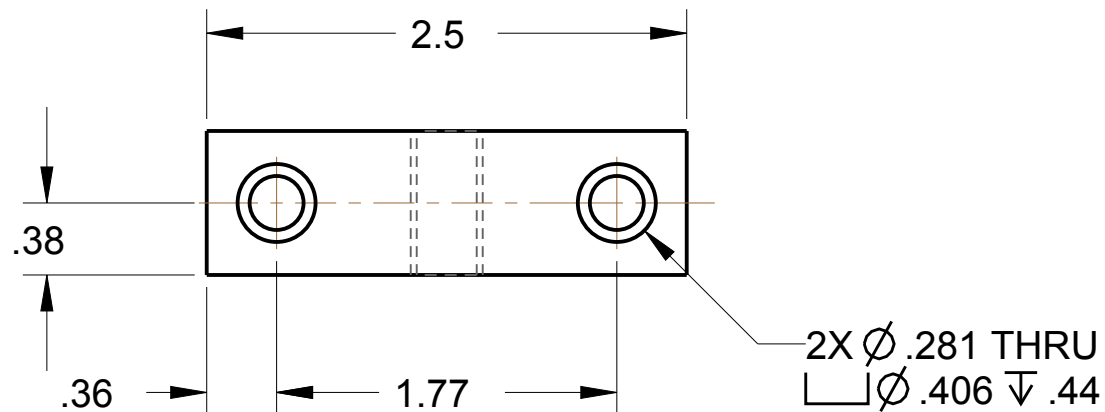

2570M0033	4		
2570M0030	4	2570M0057	4
2570M0027	4	2570M0054	4
2570M0024	4	2570M0051	4
2570M0021	4	2570M0048	4
2570M0018	4	2570M0045	4
2570M0015	4	2570M0042	4
2570M0012	4	2570M0039	4
2570M0008	4	2570M0036	4
USED ON DRAWING NO.	QTY. PER ASS'Y.	USED ON DRAWING NO.	QTY. PER ASS'Y.
APPLICATION		APPLICATION	

INTERPRET IN GENERAL ACCORDANCE WITH ASME Y14.5

UNLESS OTHERWISE SPECIFIED

DIMENSIONS ARE IN INCHES
 DECIMAL TOLERANCES
 .X± .030
 .XX± .015
 .XXX± .005

ANGULAR TOLERANCE ±1°

125
 FINISH ✓

BREAK SHARP EDGES
 MAX. .031IN. 015



COLLIDER-ACCELERATOR DEPARTMENT
 BROOKHAVEN NATIONAL LABORATORY
 UPTON, N. Y. 11973

CBETA
 GIRDER ASSEMBLY
 PUSH BLOCK

DRAWN BY	S. TRABOCCHI	03/29/17
CHECKED BY	S. RESTMEYER	3/19/18
DESIGN APPROVAL	A. ARNO	3/20/18
ENG / PHY APPROVAL	G. MAHLER	3/20/18
SUPERVISOR APPROVAL	J. TUOZZOLO	3/20/18
CEE / CME		
DIVISION HEAD		
Q.A.		
SAFETY / RSC		
DEPARTMENT CHAIR		

SIZE	DRAWING NUMBER:		REV.
B	2570M0059		A
Q.A. CATEGORY	SCALE:	WEIGHT:	SHEET
A3	1/1	0.2	1