

NOTES:

1. MATERIAL: ANGLE ALUMINUM STRUCTURAL TYPE 6061-T6 PER ASTM B308
2. VIBRO-ETCH PART WITH DRAWING NUMBER WITH MIN .12 HIGH CHARACTERS IN ACCORDANCE WITH MIL-STD-130, LOCATE APPROX AS SHOWN.

REVISION APPROVALS								
REV	ECN NO.	DESCRIPTION	DATE	BY	CHK	DES	ENG	SUPV
A	-	INITIAL RELEASE	-	-	-	-	-	-

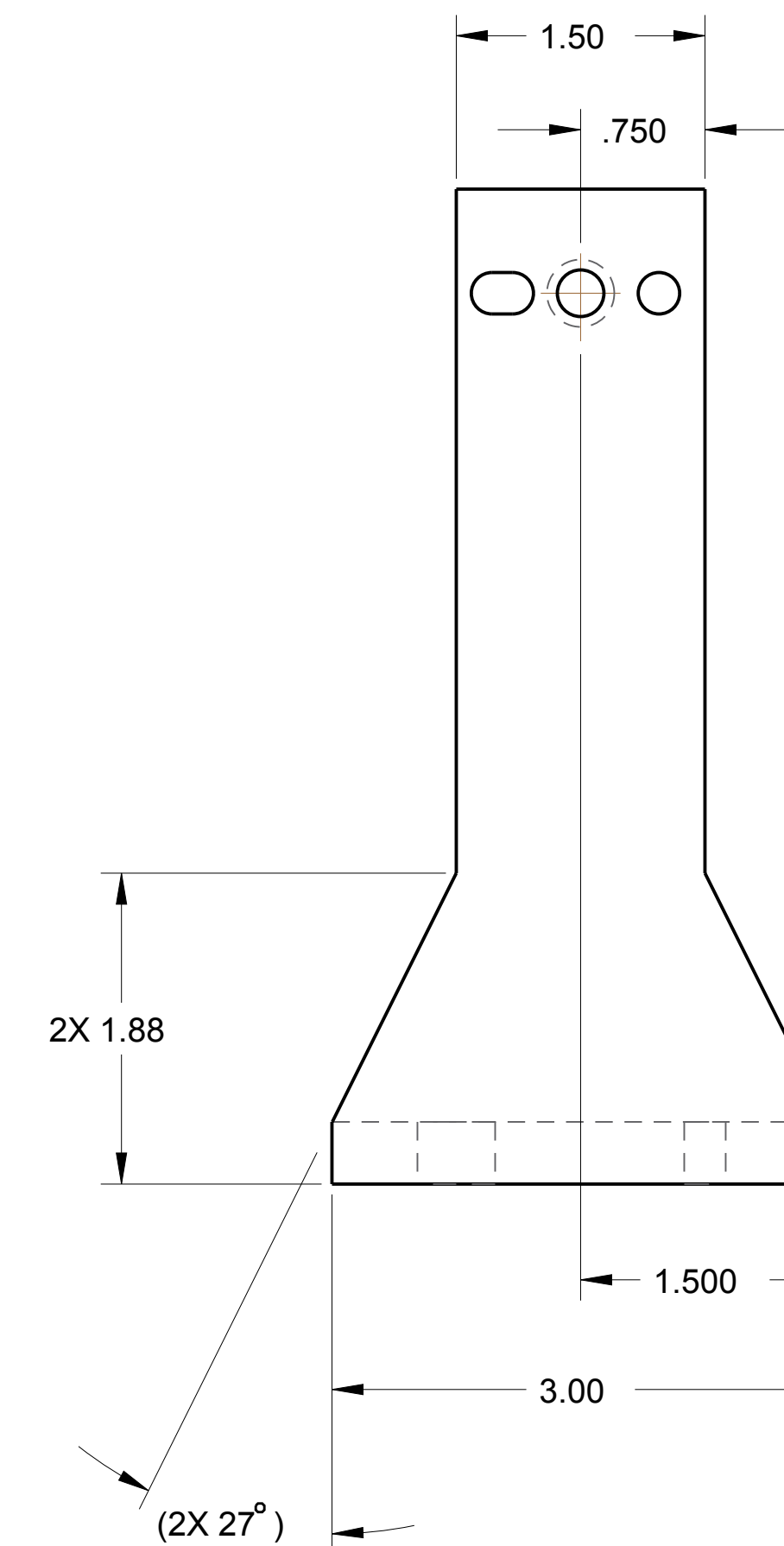
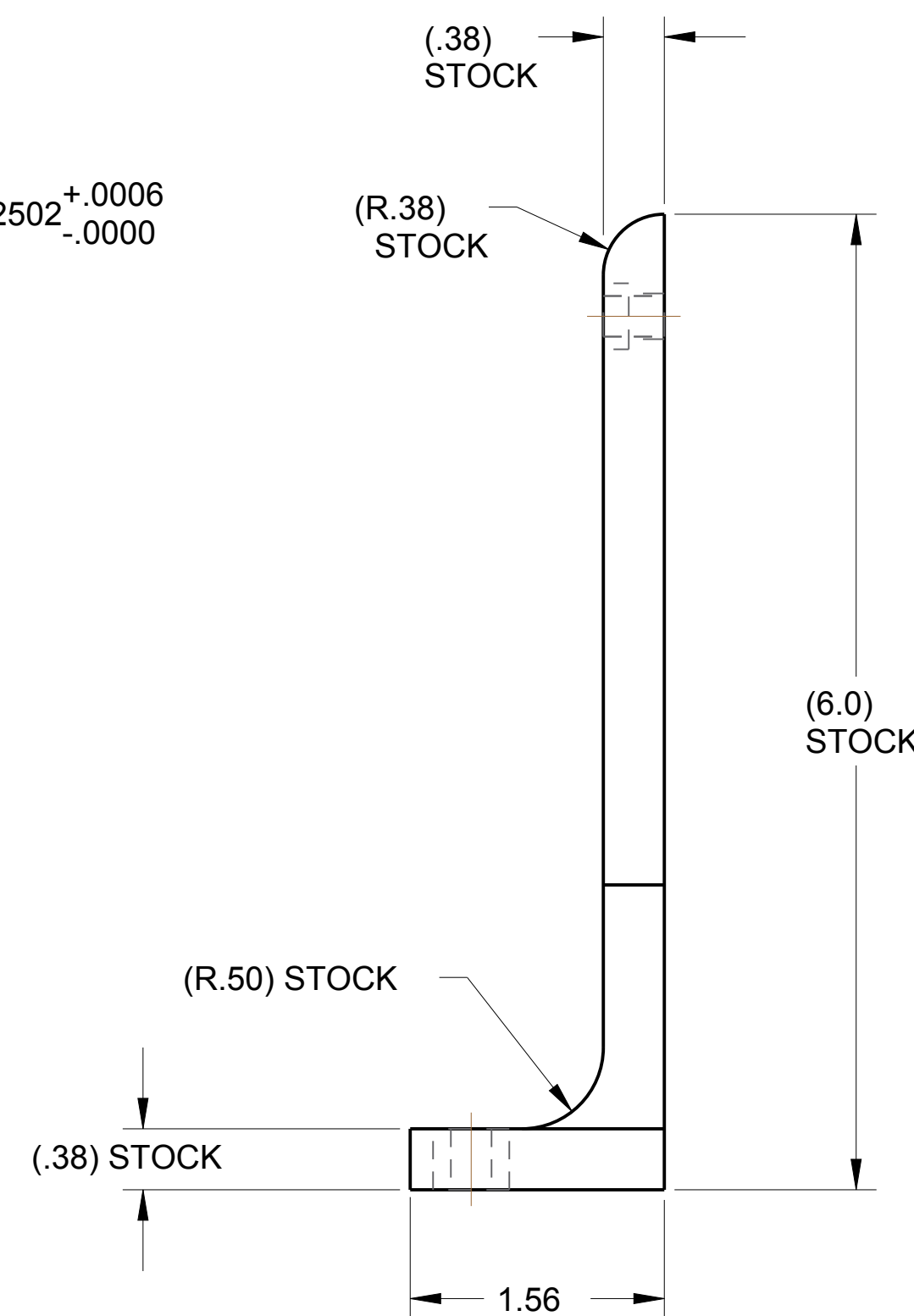
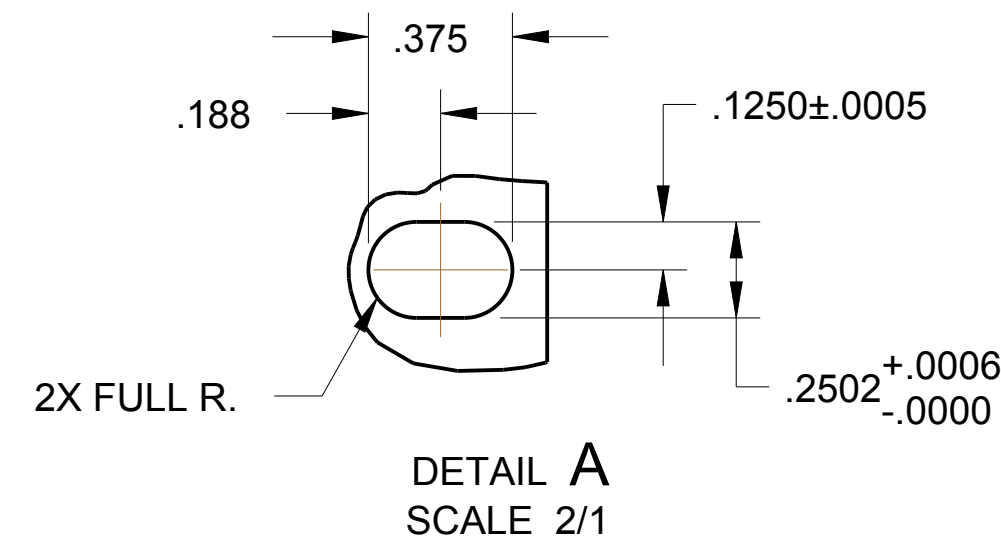
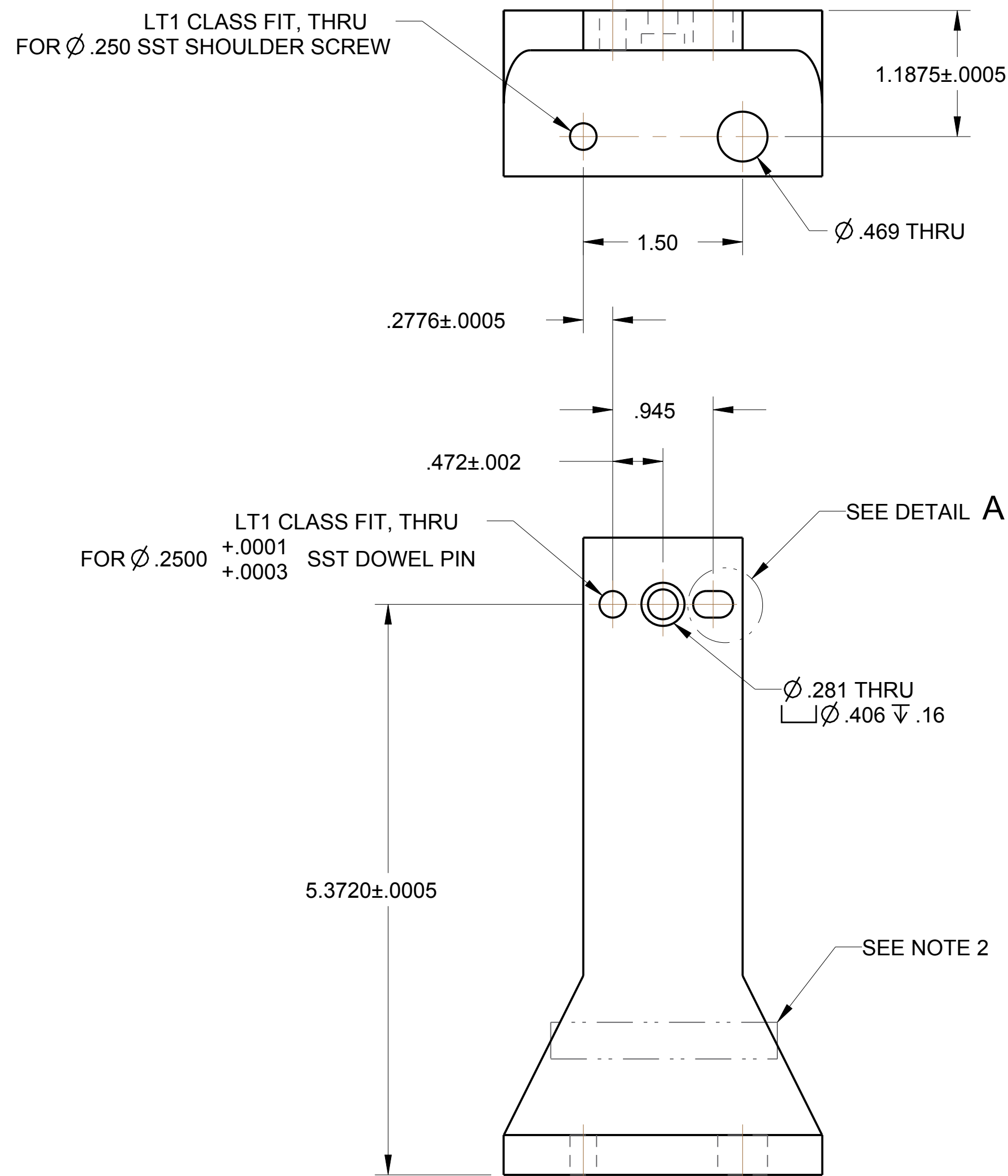

INTERPRET IN GENERAL ACCORDANCE WITH ASME Y14.5				COLLIDER-ACCELERATOR DEPARTMENT BROOKHAVEN NATIONAL LABORATORY UPTON, N.Y. 11973			
UNLESS OTHERWISE SPECIFIED		DRAWN BY: S. TRABOCCHI 08/24/17		CBETA TOP PLATE ASSEMBLY BRACKET, BPM SUPPORT, TYPE 1			
DIMENSIONS ARE IN INCHES		CHECKED BY: S. RESTMEYER 3/19/18		SIZE: D			
DECIMAL TOLERANCES		DESIGN APPROVAL: A. ARNO 3/20/18		DRAWING NUMBER: 2570M0066			
XX± .030		ENGR / PRTY APPROVAL: G. MAHLER 3/20/18		REV. A			
XXX± .015		SUPERVISOR APPROVAL: J. TUOZZOLO 3/20/18		Q.A. CATEGORY: A3			
ANGULAR TOLERANCE ±1°		CEE / CME		SCALE: 1/1			
USED ON DRAWING NO. 2570M0038		DIVISION HEAD		WEIGHT: 0.5			
QTY. PER ASSY. 1		QA		SHEET OF 1 1			
APPLICATION		SAFETY / RSC		CREO			
FINISH 125		DEPARTMENT CHAIR					
BREAK SHARP EDGES							
MAX. .001 IN. 015							

DWG NO 2570M0066

SHT 1 OF 1

CREO