

REVISIONS				
SYM	ZONE	DESCRIPTION	DATE	APP
		Initial Release		

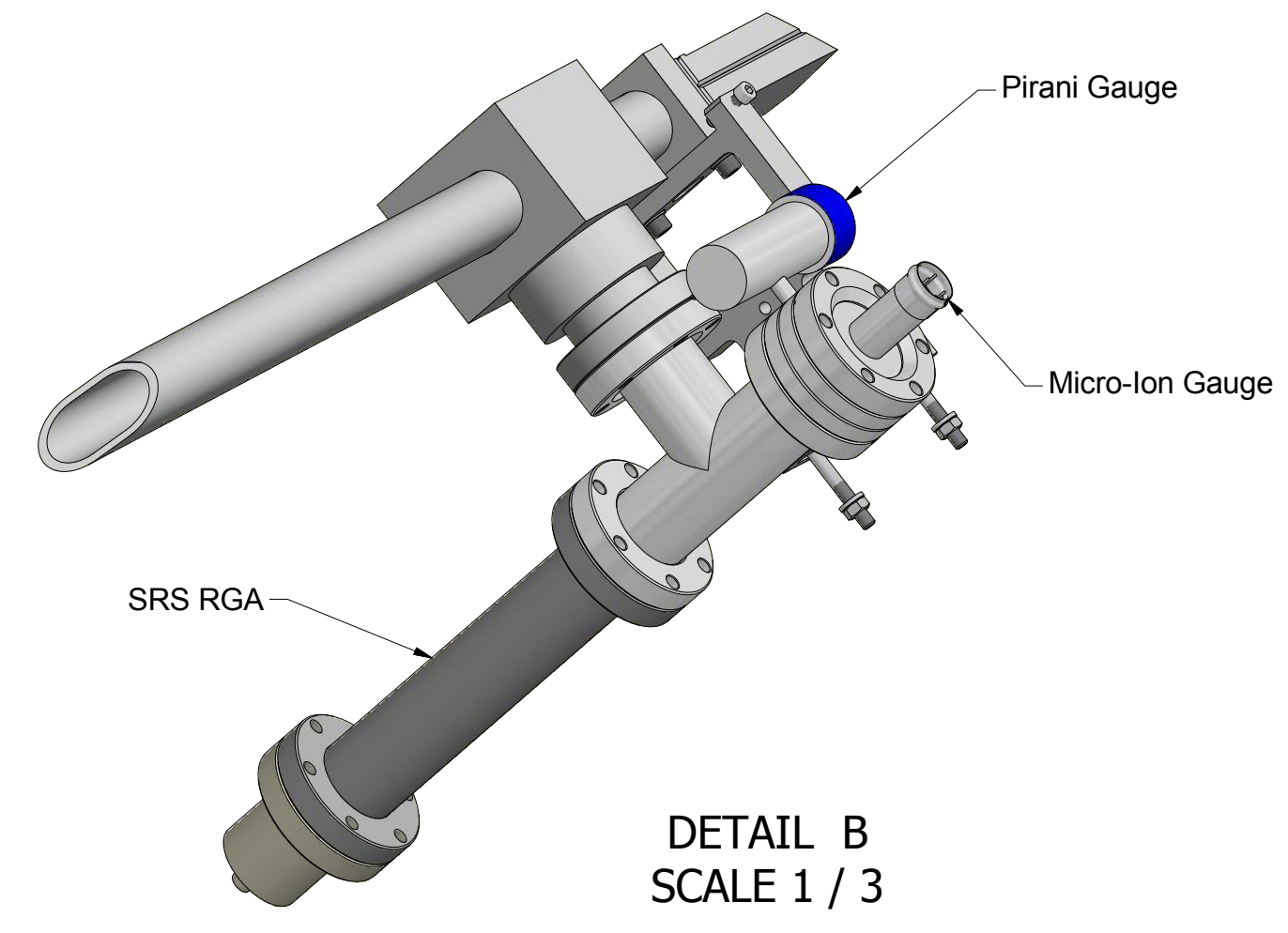
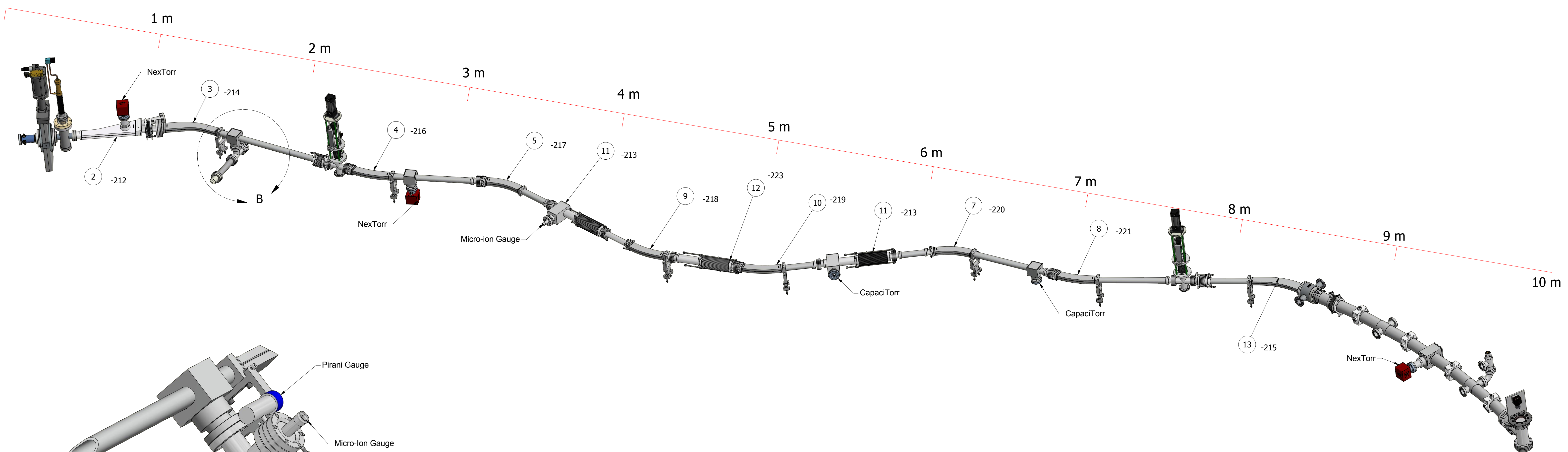

Parts List					
32	Viewer Rear Mount Camera		2		
30	7211-008	Mount Assembly, Vacuum Chambers	7		
29	Purchased	Pirani Gauge on DS CF275	1		MKS Model 275
28	Purchased	2-3/4" CF Tee	1		MDC's #404002
26	7208-302	Stationary Viewer	1		
25	Purchased	SRS RGA	1		
24	Purchased	2-3/4" Non-Rot Blank	1		
22	Purchased	355 Micro-Ion Gauge, 2-3/4"CF Flange	2		Granville-Phillips 355001-YG
20	Purchased	CapaciTorr D100	2		
19	Purchased	MLC_test_east_end	1		
18	Purchased	1-1/2" Right Angle Valve, 2-3/4" CF Flanges	1		Varian 951-5027
17	Purchased	2-3/4" CF Elbow, 90 Deg.	1		MDC's 403002
16	Purchased	NEXTorr D100-5	3		
15	7206-625	DN63 GV Replacement Cross	1		Lesker #A0056173
14	7206-301	First FFAG Girder Beampipe	1		CLASSE
13	7206-215	Common Dipole Chamber, S1-BEN08	1		CLASSE
12	7206-223	FAT Center Sliding Joint Assembly	1		CLASSE
11	7206-213	FAT Sliding Joint Assembly W/ Pump	2		CLASSE
10	7206-219	Splitter Dipole Chamber S1-BEN05	1		CLASSE
9	7206-218	Splitter Dipole Chamber S1-BEN04	1		CLASSE
8	7206-221	Splitter Dipole Chamber S1-BEN07	1		CLASSE
7	7206-220	Splitter Dipole Chamber S1-BEN06	1		CLASSE
5	7206-217	Splitter Dipole Chamber S1-BEN03	1		CLASSE
4	7206-216	Splitter Dipole Chamber S1-BEN02	1		CLASSE
3	7206-214	Common Dipole Chamber S1-BEN01	1		CLASSE
2	7206-212	Dipole Chamber - Beam Dump Weldment	1		CLASSE
1	Reference	7200-310 Lattice, Splitter, SX	1		BMAD

ITEM	DWG. NO.	DESCRIPTION	G1	G2	G3	REMARKS	REV.
			QUANTITY				
PRINT DATE: _____ CAD FILE NAME: 7206-224.idw							
D SH. NO. 1 OF 4	CR-1 UNLESS OTHERWISE SPECIFIED: DIMENSIONS ARE IN MILLIMETERS; TOLERANCES ON: X ± .5 XX ± .2 XXX ± .1 ANGLES ± 0.5° ALL SURFACES \sqrt{R}	Cornell Laboratory for Accelerator-based ScienceS and Education (CLASSE)		Vacuum String from MLC to End of Fractional Arc			
	CHECKED BY: _____ APPROVED BY: _____	DRAWN BY: _____	DRAWN FOR: _____	DATE: 1/11/2018	SCALE: D	7206-224 SH. NO. 1 OF 4	REV. _____

REVISIONS				
SYM	ZONE	DESCRIPTION	DATE	APP
		Initial Release		

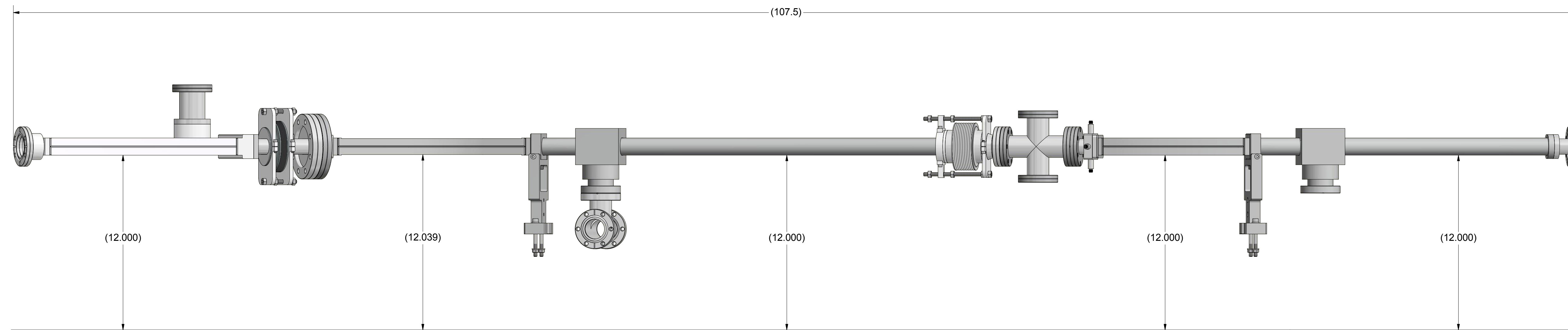

Artificial Flat Top

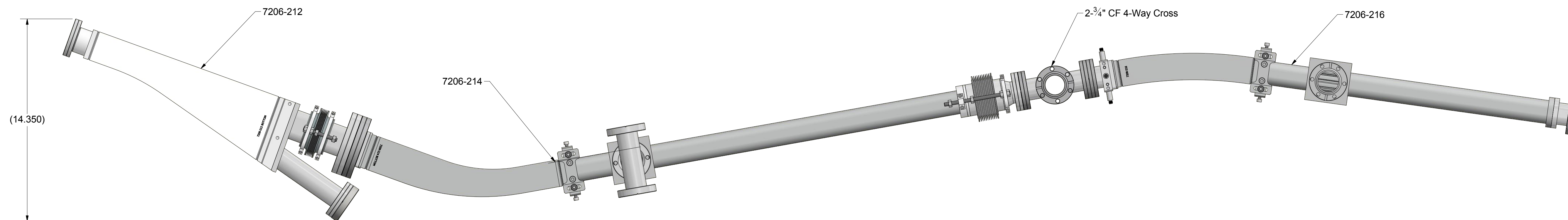

FAT S1 String #1

ITEM	DWG. NO.	DESCRIPTION	G1	G2	G3	REMARKS	REV.
			QUANTITY				
D	PRINT DISTR.	PLOT DATE: CAD FILE NAME: 7206-224.idw					
7206-224 SH. NO. 2 OF 4	CR-1	UNLESS OTHERWISE SPECIFIED: DIMENSIONS ARE IN MILLIMETERS; TOLERANCES ON: X ± 5 XX ± 2 XXX ± 1 ANGLES ± 0.5° ALL SURFACES √ ₅	 Cornell Laboratory for Accelerator-based ScienceS and Education (CLASSE)				
	Vacuum String from MLC to End of Fractional Arc Beampipe String #1						
REV.	CHECKED BY:	DRAWN BY	DRAWN FOR	DATE	SCALE	D	7206-224 SH. NO. 2 OF 4
	APPROVED BY:			1/11/2018			

REVISIONS				
SYM	ZONE	DESCRIPTION	DATE	APP
		Initial Release		

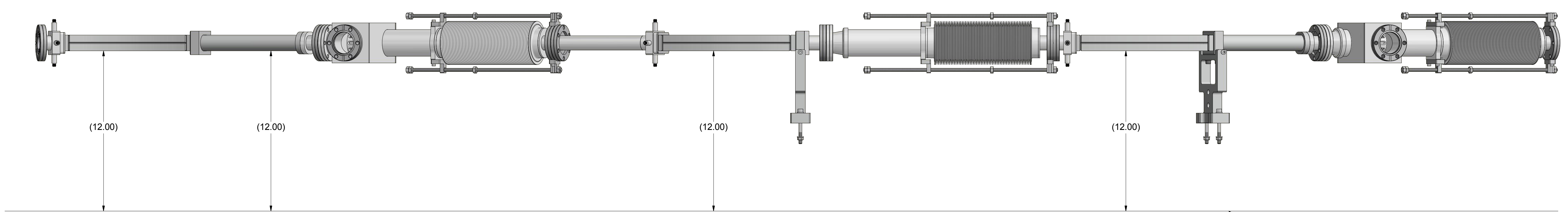
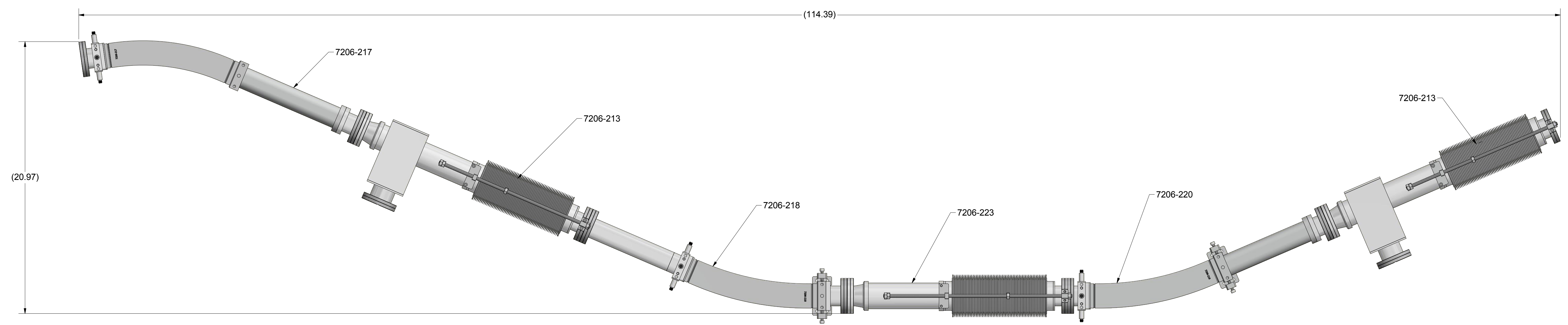

FAT S1 String #2

ITEM	DWG. NO.	DESCRIPTION	G1	G2	G3	REMARKS	REV.
			QUANTITY				
PRINT DISTR.	PLOT DATE: CAD FILE NAME: 7206-224.idw						
7206-224 SH. NO. 3 OF 4	CR-1	UNLESS OTHERWISE SPECIFIED: DIMENSIONS ARE IN MILLIMETERS; TOLERANCES ON: X ± 5 XX ± 2 XXX ± 1 ANGLES ± 0.5° ALL SURFACES √ _R	 Cornell Laboratory for Accelerator-based ScienceS and Education (CLASSE)		Vacuum String from MLC to End of Fractional Arc Beampipe String #2		
	CHECKED BY: APPROVED BY:	DRAWN BY	DRAWN FOR	DATE	SCALE	D	7206-224 SH. NO. 3 OF 4

REVISIONS				
SYM	ZONE	DESCRIPTION	DATE	APP
		Initial Release		

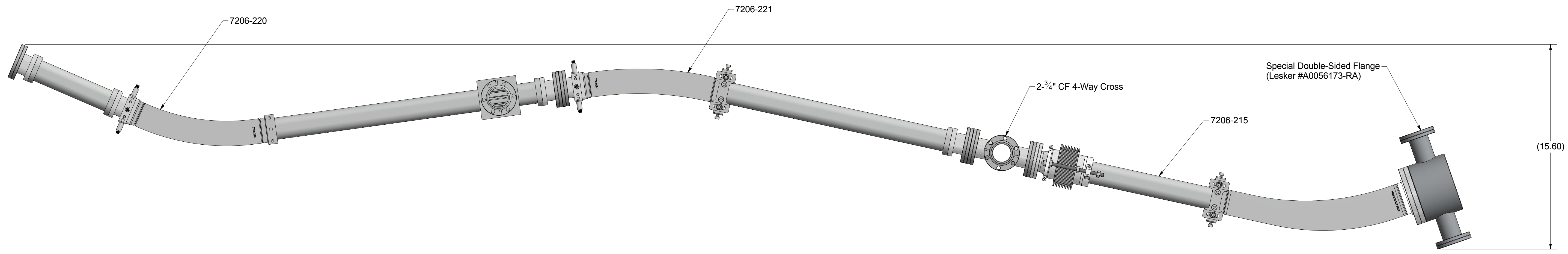
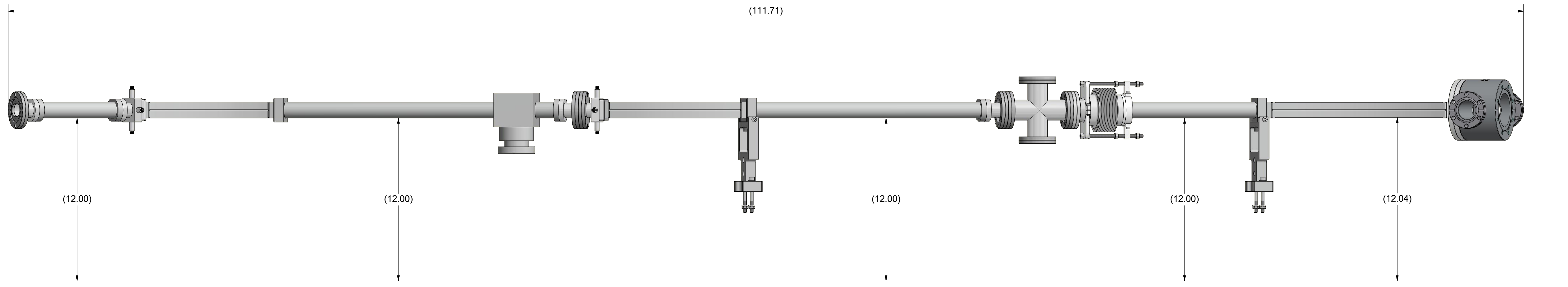

FAT S1 String #3

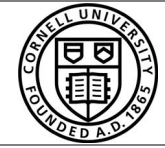
REV.	ITEM	DWG. NO.	DESCRIPTION	G1	G2	G3	REMARKS	REV.
				QUANTITY				
D	PRINT DISTR.		PLOT DATE: CAD FILE NAME: 7206-224.idw					
7206-224 SH. NO. 4 OF 4	CR-1		UNLESS OTHERWISE SPECIFIED: DIMENSIONS ARE IN MILLIMETERS; TOLERANCES ON: X ± .5 XX ± .2 XXX ± .1 ANGLES ± 0.5° ALL SURFACES \sqrt{R}	 Cornell Laboratory for Accelerator-based ScienceS and Education (CLASSE)			Vacuum String from MLC to End of Fractional Arc	
	CHECKED BY:		DRAWN BY	DRAWN FOR	DATE	SCALE	D	7206-224 SH. NO. 4 OF 4
	APPROVED BY:				1/11/2018			