

PG_CARRIER = Carrier Good Power Indicator (Open Collector Wired Or)

VCCIO_EN is provided by the power good output of the 1.8V regulator on the uZED board

microZed Breakout Board MBCC-BKO

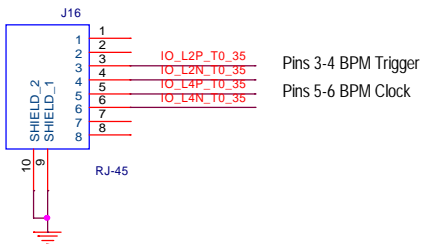
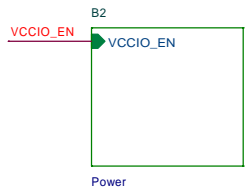
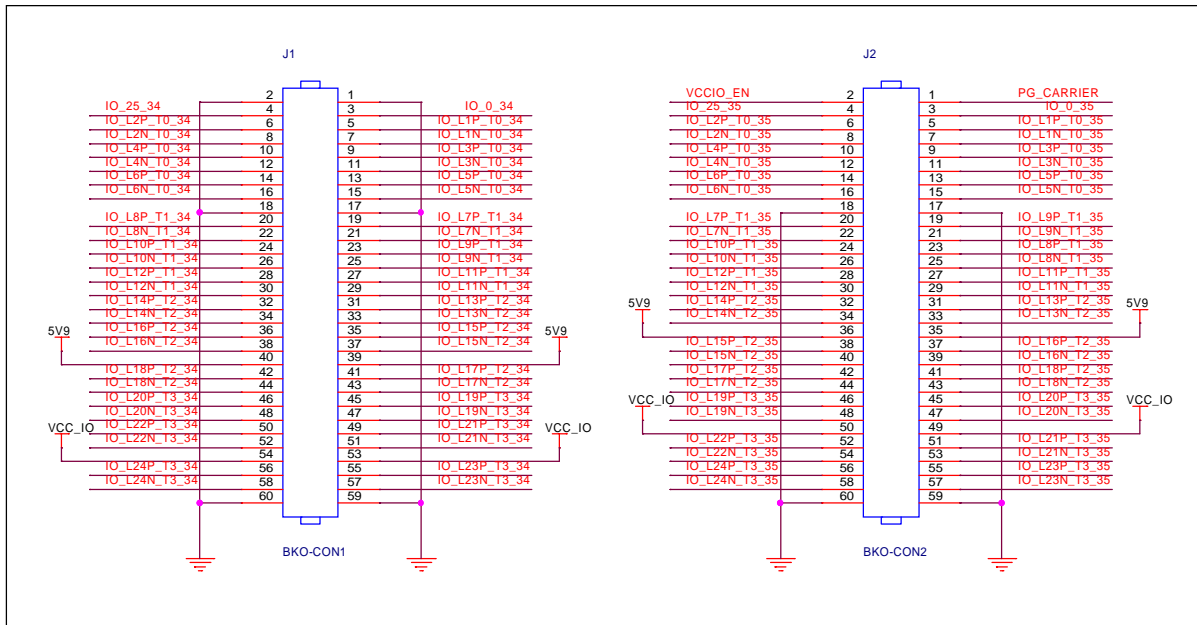

Title	<Title>	
Size	Document Number	Rev
B	<Doc>	<RevC>
Date:	Friday, January 18, 2019	Sheet 1 of 4

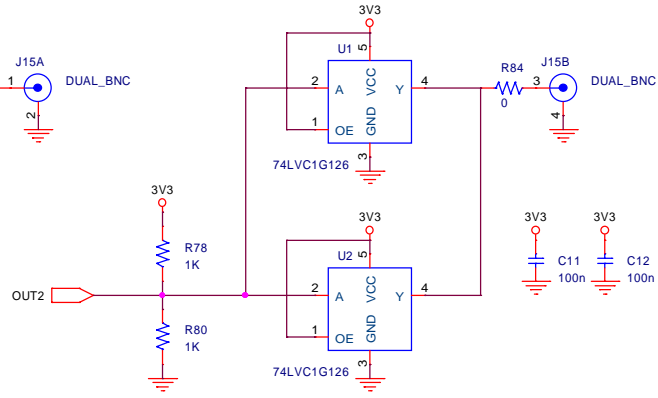
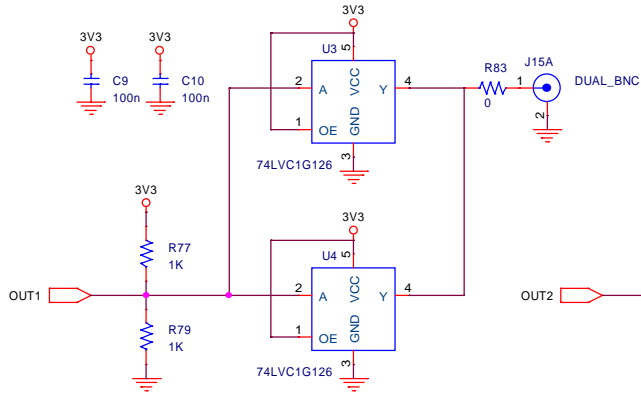
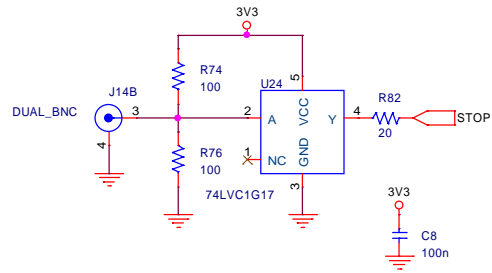
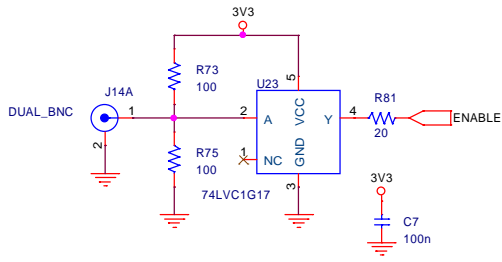

Title	<Title>	
Size	Document Number	Rev
B	<Doc>	<RevCod
Date:	Friday, January 18, 2019	Sheet 2 of 4

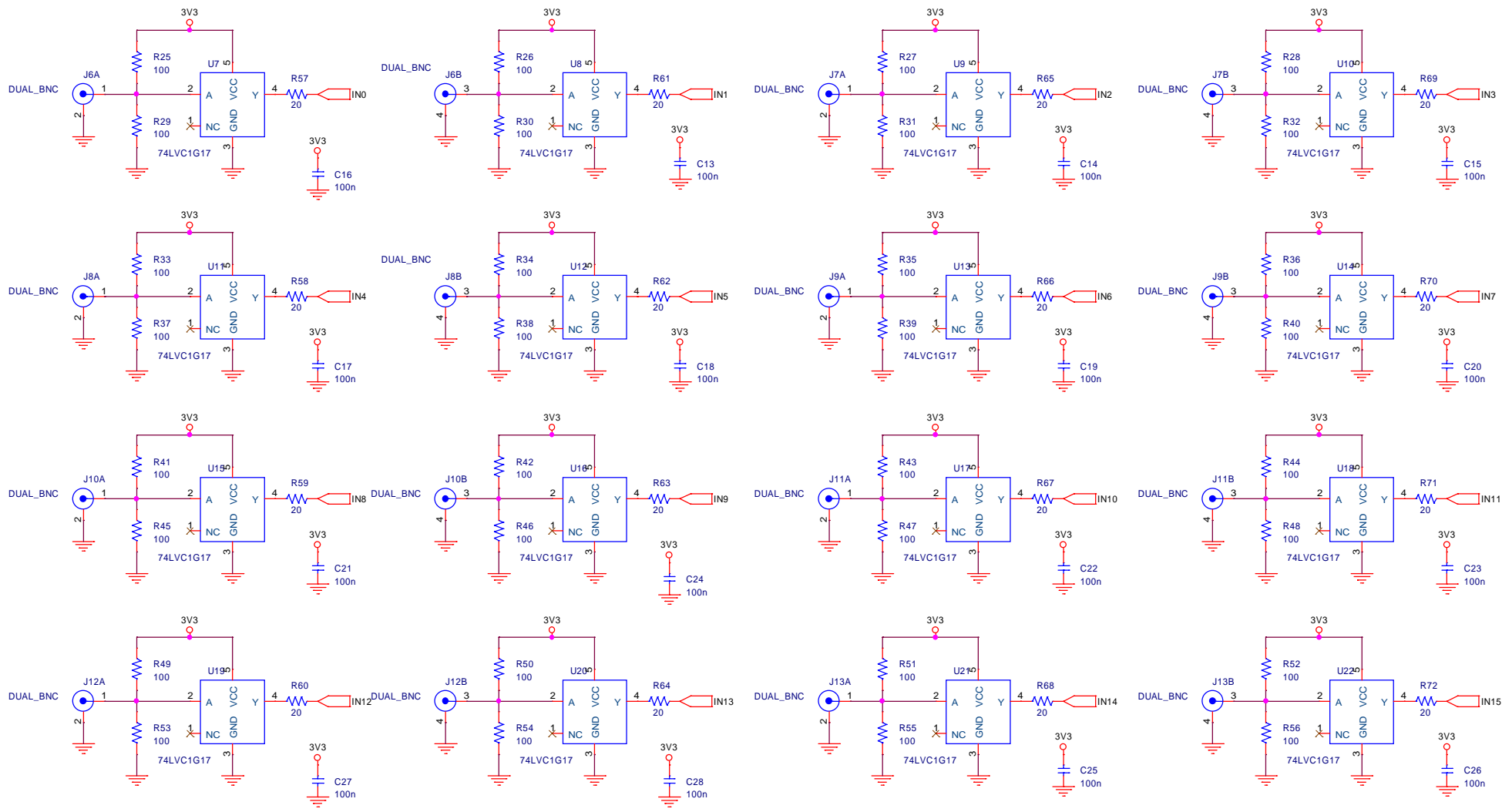

Title	<Title>	
Size	Document Number	Rev
B	<Doc>	<RevCod
Date:	Friday, January 18, 2019	Sheet 3 of 4

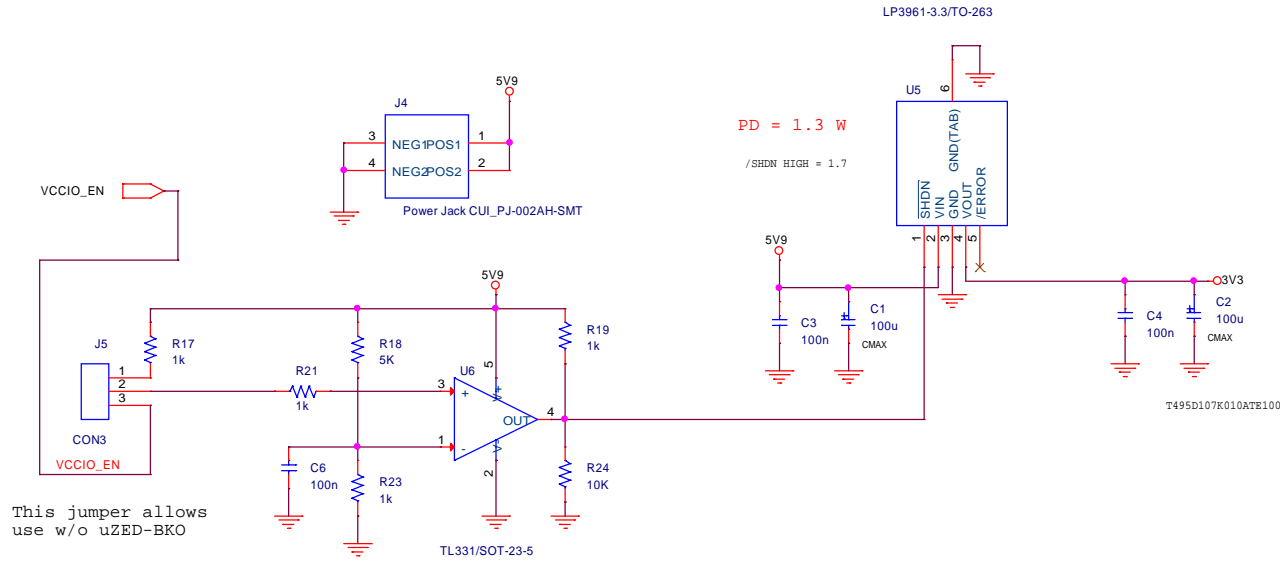
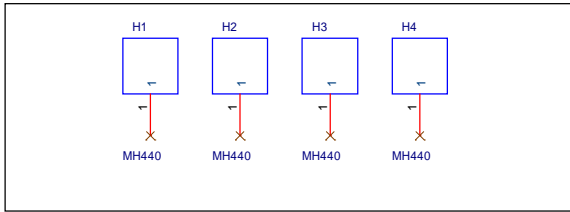

This jumper allows
use w/o uZED-BKO

Title	<Title>	
Size	Document Number	Rev
B	<Doc>	<RevCod
Date:	Friday, January 18, 2019	Sheet 4 of 4