

Positron Undulator Progress Report

Submitted April 2007 by Cornell University
A. Mikhailichenko, M. Tigner

Purpose

A superconducting, helical undulator based source has been selected as the baseline design for the ILC. This report outlines progress towards design, modeling and testing elements of the needed undulator. A magnetic length of approximately 150 m is needed to produce the desired positron beam. This could be composed of about 50 modules of 4 m overall length each.

This project is dedicated to the design and eventual fabrication of one full scale, 4 m long undulator module. The concept builds on a copper vacuum chamber of 8 mm internal bore [1].

Progress to Date

An overall concept design for the module as shown in Fig. 7 has been developed. The design is very compact, having an outside cryostat diameter of 100 mm. Standard size plumbing components are used throughout. Figure 1 shows the cross section design for tapered end coils.

We have made optimization studies for undulators having 10 and 12 mm period with 8 mm clear bore and wound with various commercially available wires.

Technology for fabrication of the undulator has been reduced to practice including winding of the wire and the helical iron yoke as well as procedures and apparatus for measuring the field distribution at the operating temperature.

Several 40 cm long undulator models with 10 and 12 mm period, 8 mm clear bore have been made and measured. See table 1

Table 1: Parameters of tested and planned undulators.

SC wire	54 filaments	56 filaments	56 filaments
# layers	5*	6*	9** (12***)
$\lambda=10\text{ mm}$	K=0.36 tested	K=0.42 tested	K \approx 0.5 (calculated)
$\lambda=12\text{ mm}$	K=0.72 tested	K=0.83 tested	K \approx 1 (calculated)

*) Wire – Ø0.6 mm bare

**) Wire – Ø0.4 mm bare

***) Wire – Ø0.3 mm bare

Figures 1 – 5 show photos of the models and measurement results for the 6 layer, 12 mm period model of 40 cm length. 9 layer models soon to be made and tested will push the achievable K significantly higher.

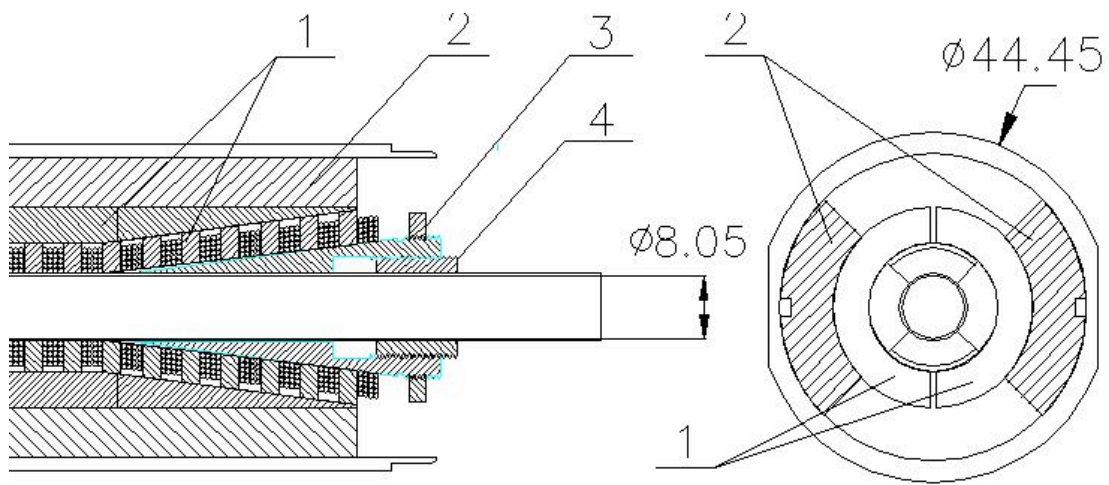

Fig. 1 Details of cold mass design at the fringe with conical tapering. 1–Iron yoke, 2–Copper collar, 3, 4–trimming Iron nuts. Inner diameter of Copper vacuum chamber is 8.05mm clear.

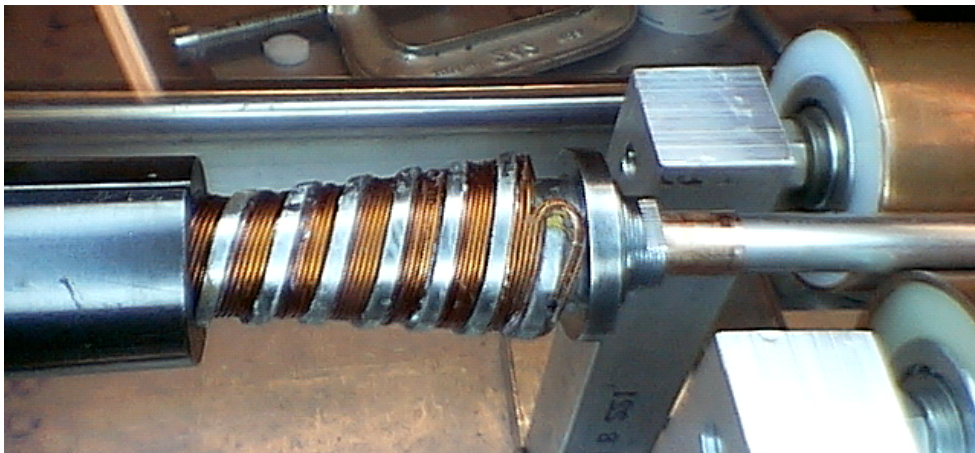

Fig. 2 Conical coil end during fabrication



Fig. 3 Coil end of Figs. 1&2 during assembly of the model.

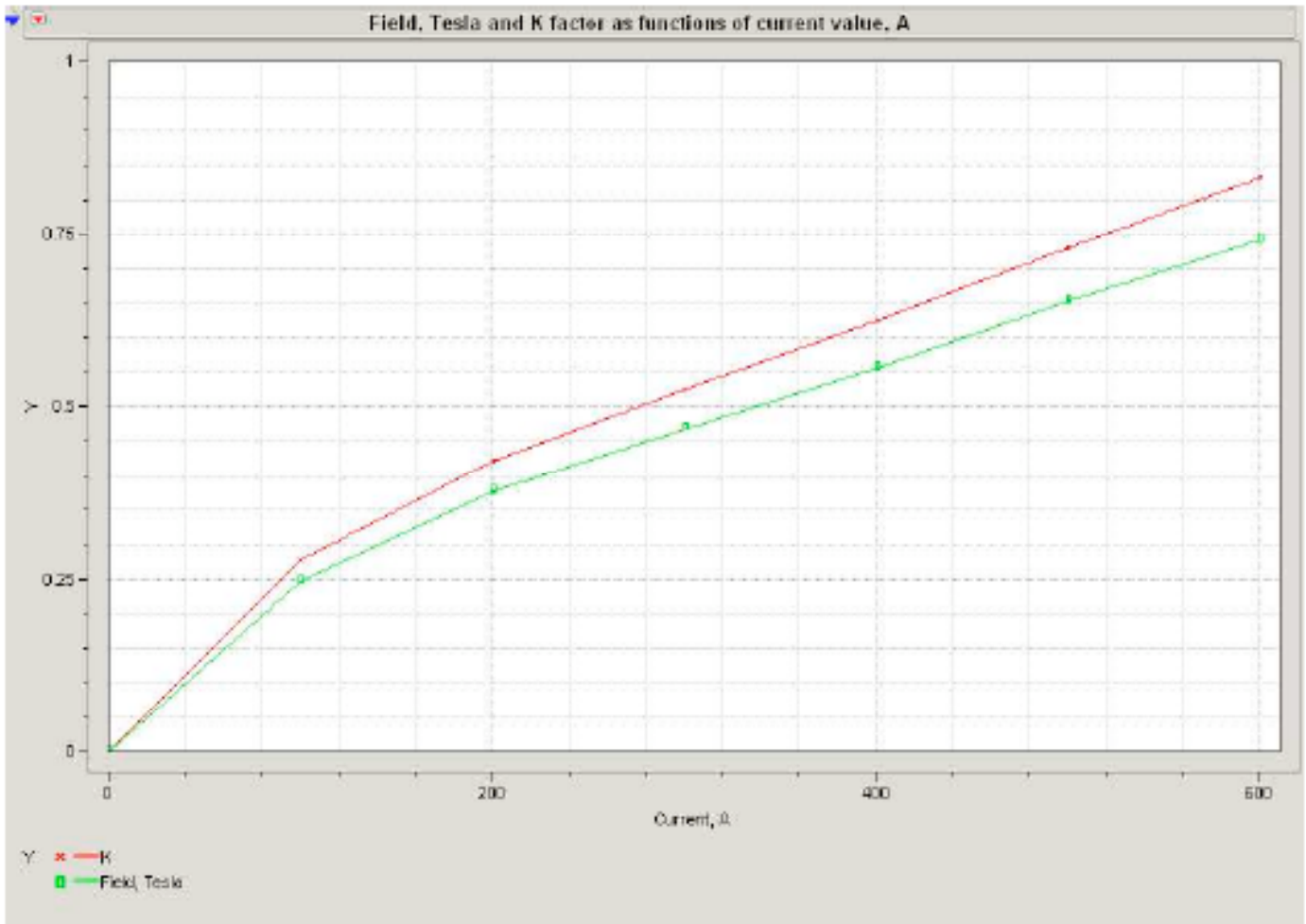

Fig. 4 Excitation curve for 6 layer, 12 mm period model - K value in red and field in green

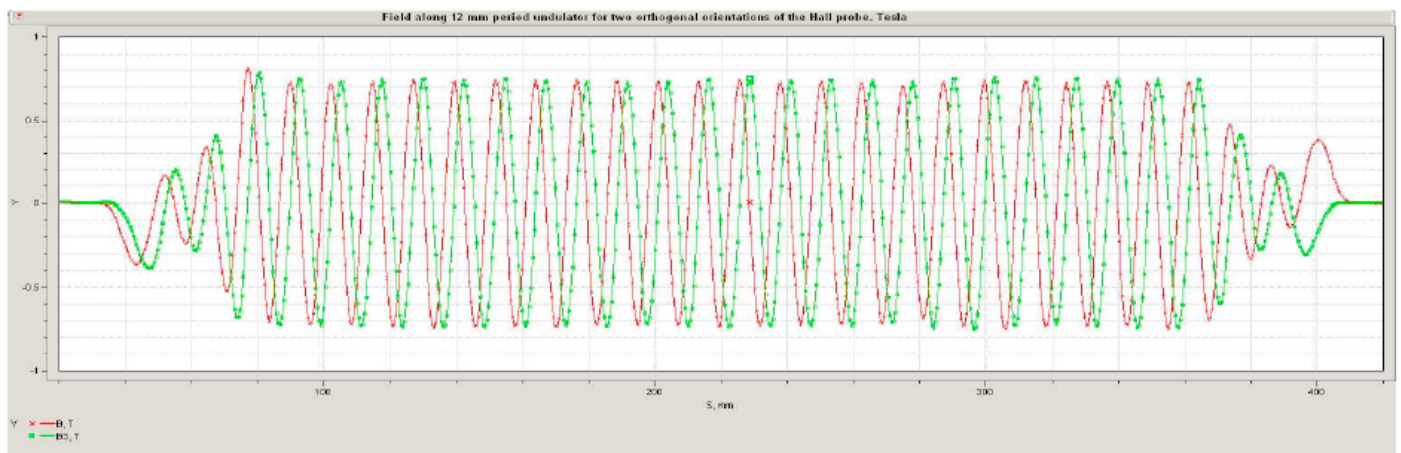

Fig. 5 Field profile – conical ends. 6 layer, 12 mm period – orthogonal hall probes. 1 Tesla full scale



Fig. 6. 1m long model of undulator cryostat for testing with 40 cm model cores waiting for assembly

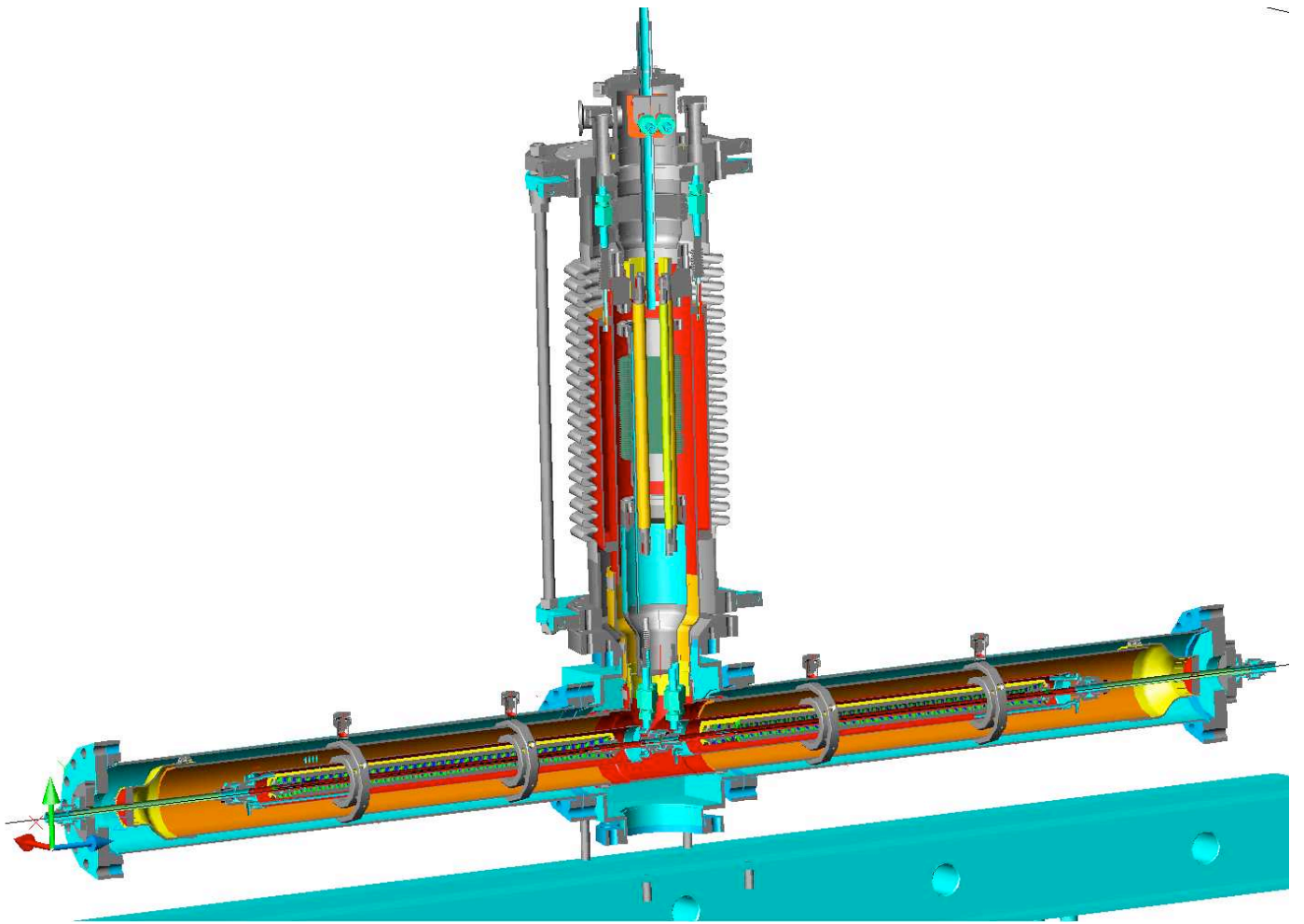

Fig. 7 Extensible prototype concept for ILC positron undulator

-
- [1] A.Mikhailichenko, “*Status and Plans of Cornell Undulator Prototyping*”, ILCW, Valencia, 6-10 November 2006, see: <http://iflc.uv.es/%7Eilc/ECFA-GDE2006/>