



# Development of a Fast High-Power Pulsed and ILC DR Injection/Extraction Kicker

Anatoly Krasnykh (SLAC)

ILC Damping Ring R&D Workshop  
Cornell University

September 26-28, 2006

# Contents

1. Introduction: Higher Order Mode (HOM) Considerations
2. Modulator Topologies
3. Experimental Evaluation of the Drift Step Recovery Device (DSRD)-based Pulser Topology
4. Kicker Electrodynamics: Development of Reduced Beam Impedance Kicker Structures

# 1. Introduction

(Experimental results: SLAC Transverse Feed Back (TFB) Kicker)

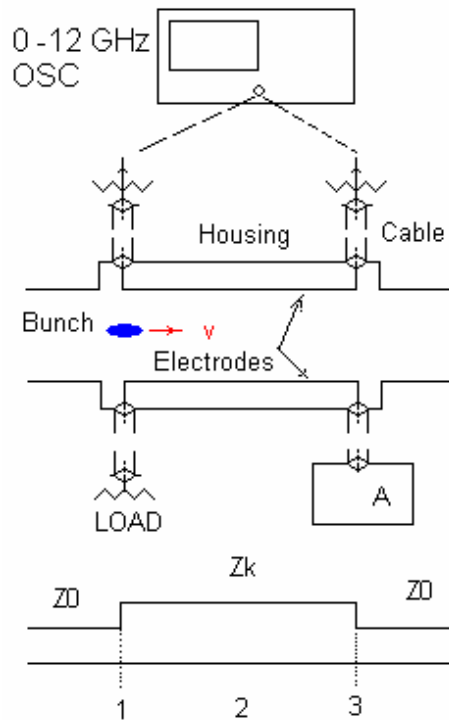

$I_b = 0.62A$ , 801 bunches

$V_p = 450V @ 50\Omega$

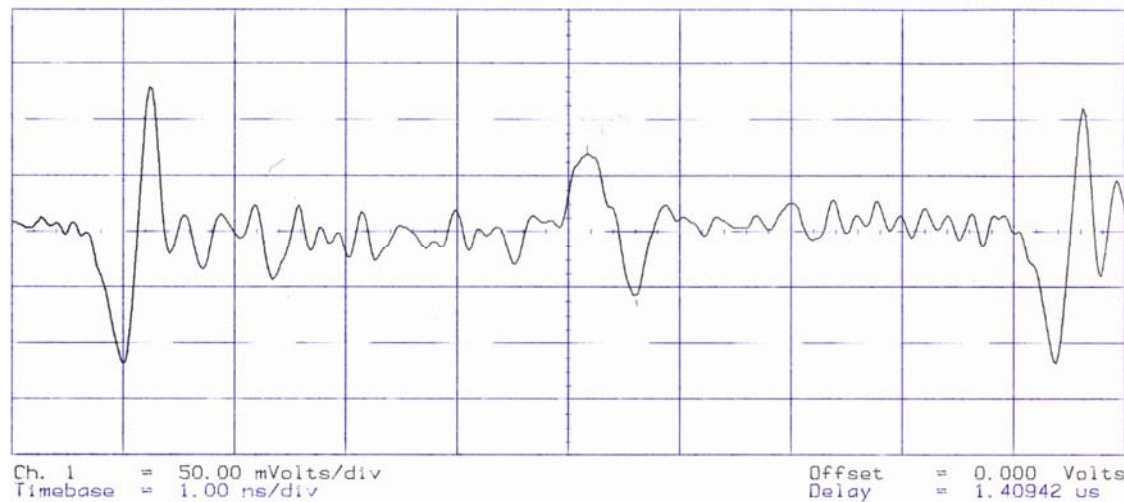
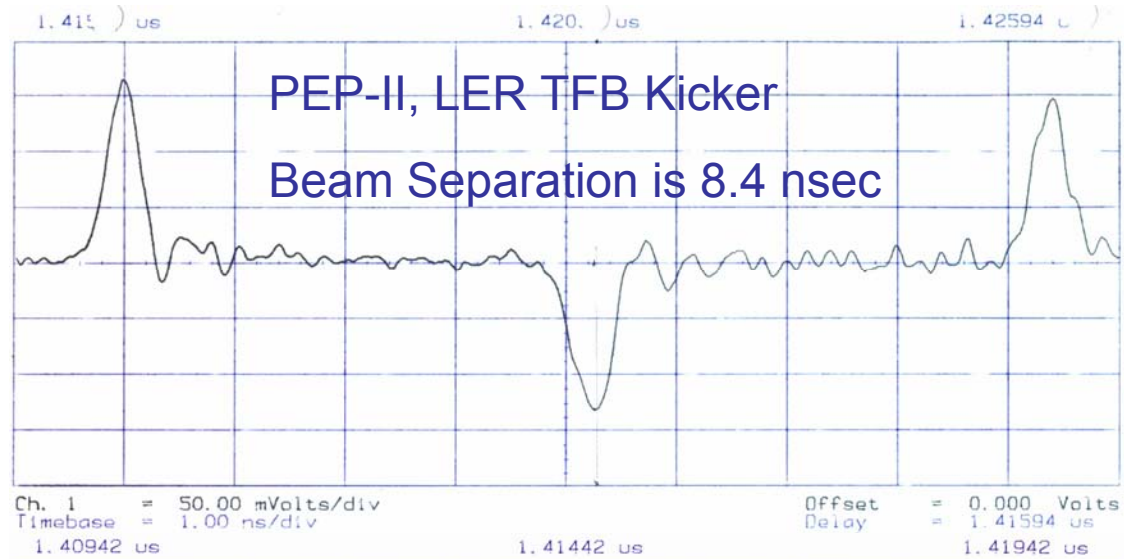

# Introduction (cont.)

## KEK ATF DR Kicker

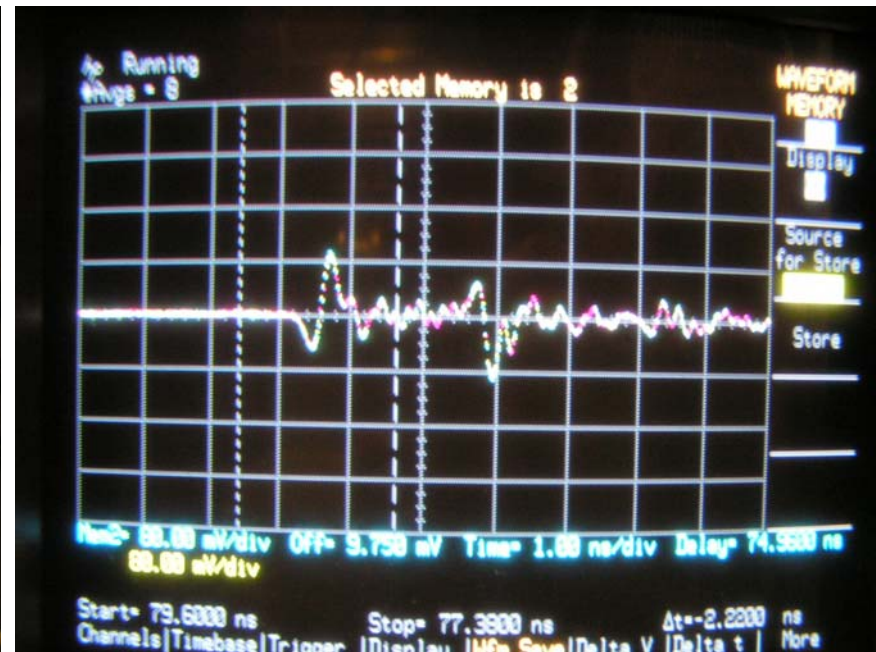
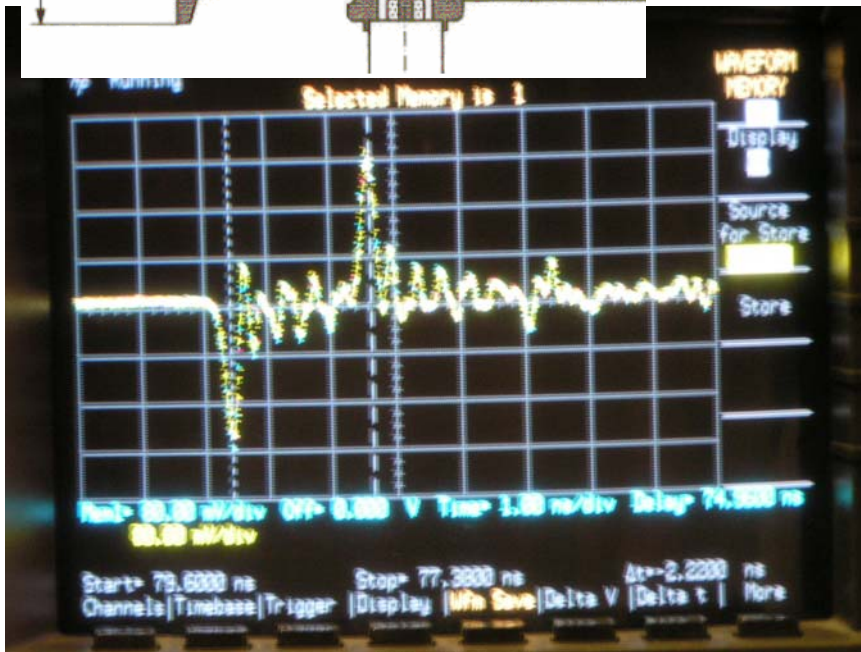
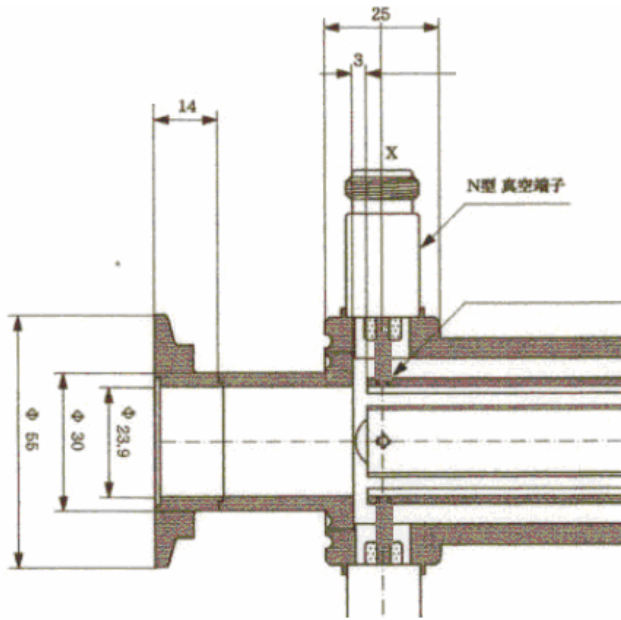

Single Bunch Mode Operation

## Introduction (cont.)

### HOM Power at the Upstream Kicker Feeder

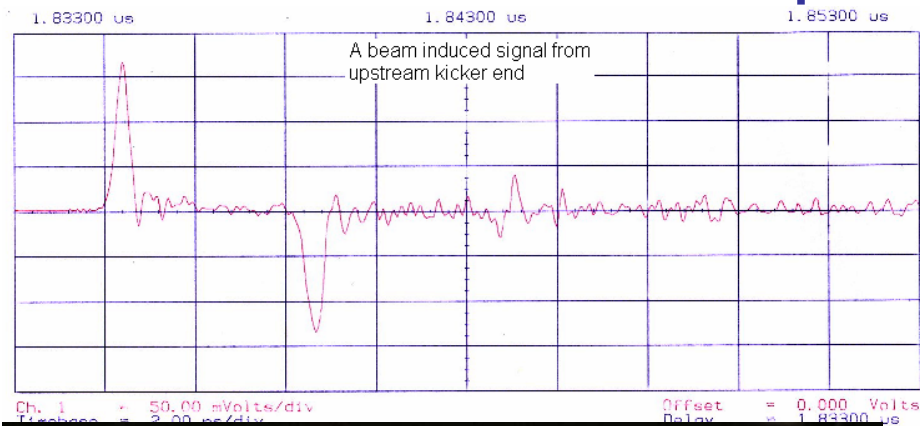

PEP-II TFB Kicker

63 cm (2.1 nsec)

(single bunch mode)

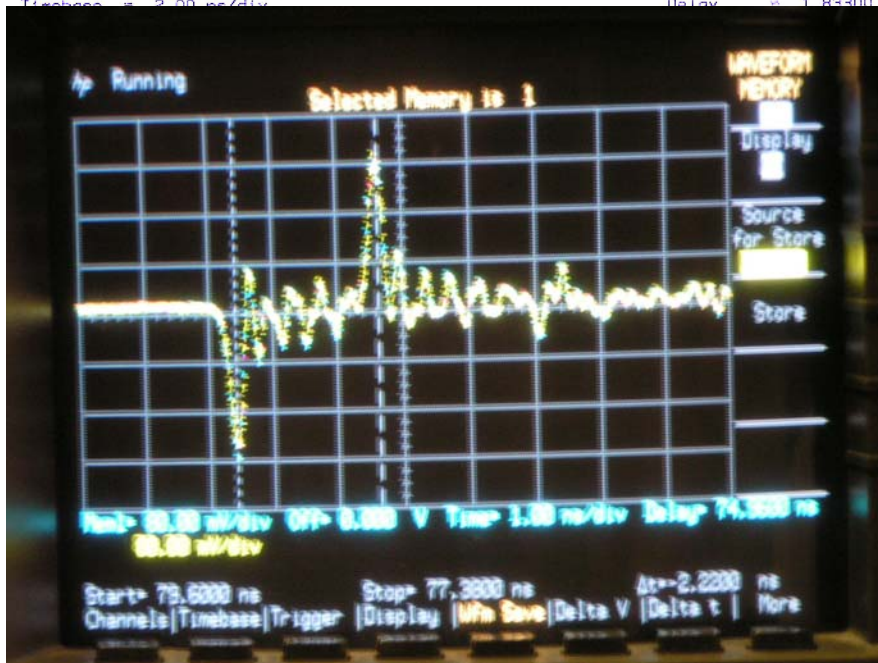

KEK ATF DR Kicker

# Introduction (cont.)

## HOM Power at the Downstream Kicker Feeder

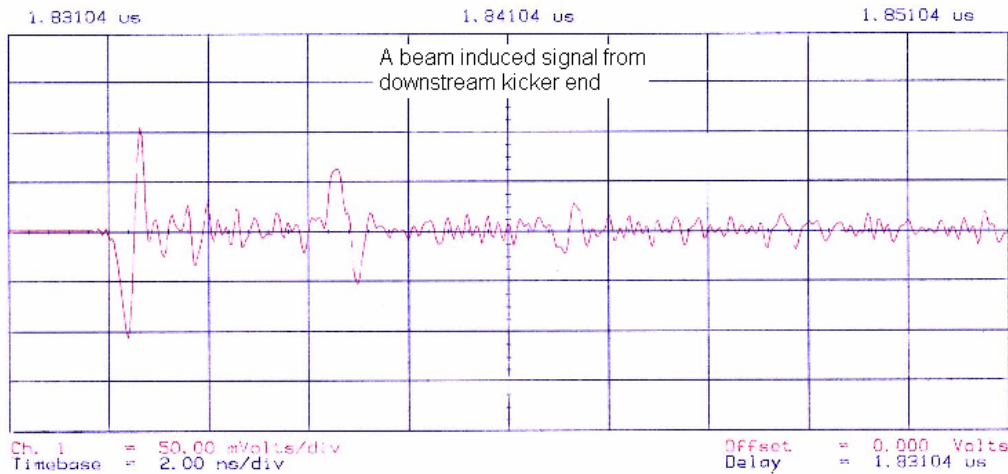

PEP-II TFB Kicker  
(single bunch mode)

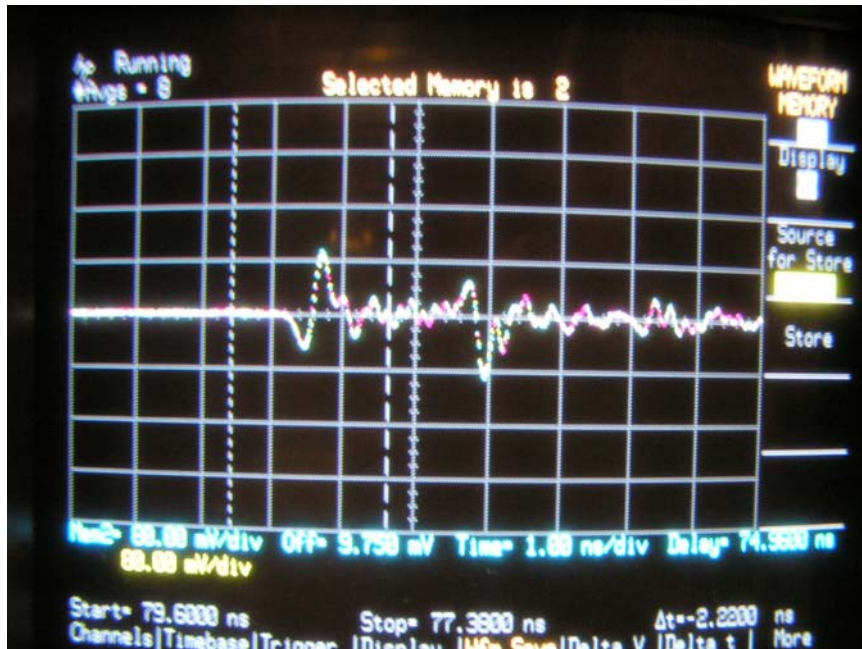

KEK ATF DR Kicker

# Introduction Summary

- Kicker is an efficient HOM power extractor
- Peak HOM voltage and average power at the feeder may be sufficient to act on the kicker pulser
- Feeder imperfections (real cable, feedthroughs, kicker electrodes, loads) is one source of residual energy between bunches
- HOM spectrum is broad

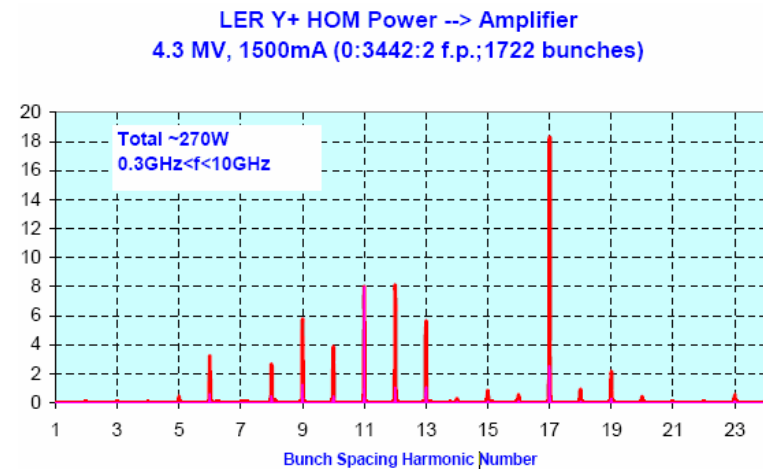

## 2. Modulator Topologies: MW Power Level, Nanosecond Pulse Length

- Inductive Adder
- If we assume that there is an ideal super power switch (super fast ON switch or super fast OFF switch, arbitrary voltage):
  - What topology would be favored for ILC DR kicker pulser?
  - How will HOM power affect the pulser?



## 2.1 SLAC/LLNL Concept

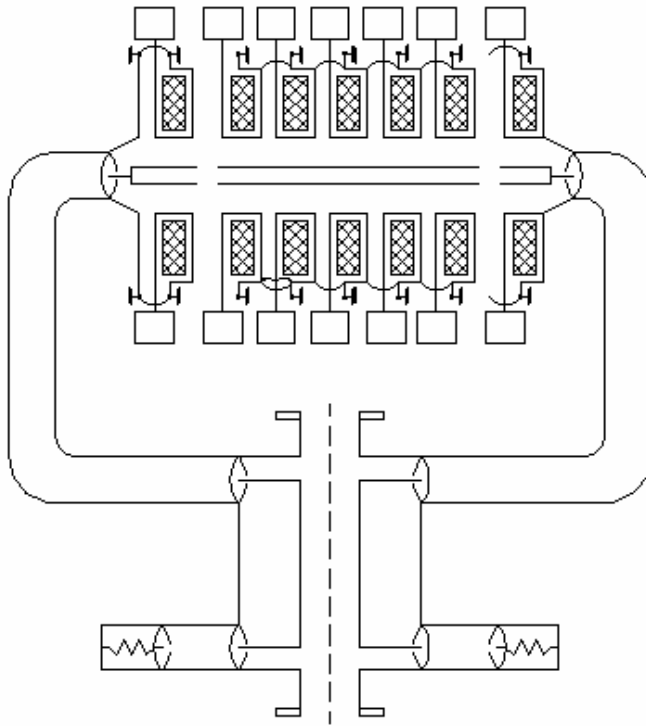

Can the induction system transmit the super fast rise time?

What is the best material for induction cell? Efficiency vs. degree of the pulse distortion

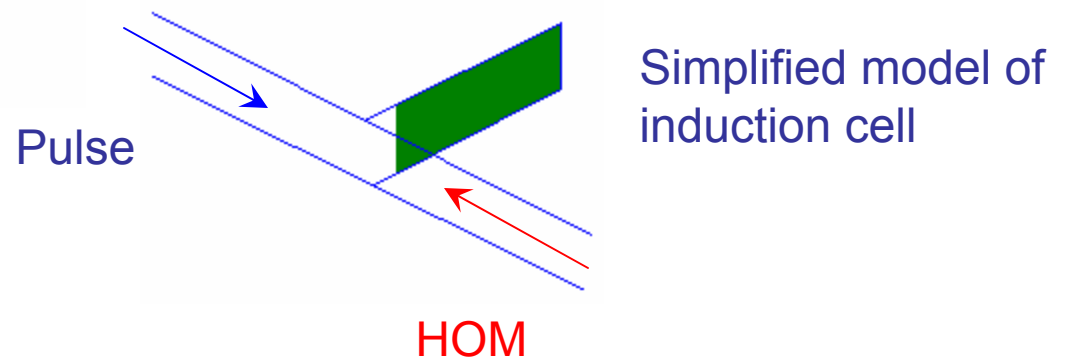

## 2.1 HOM Power to the Pulser

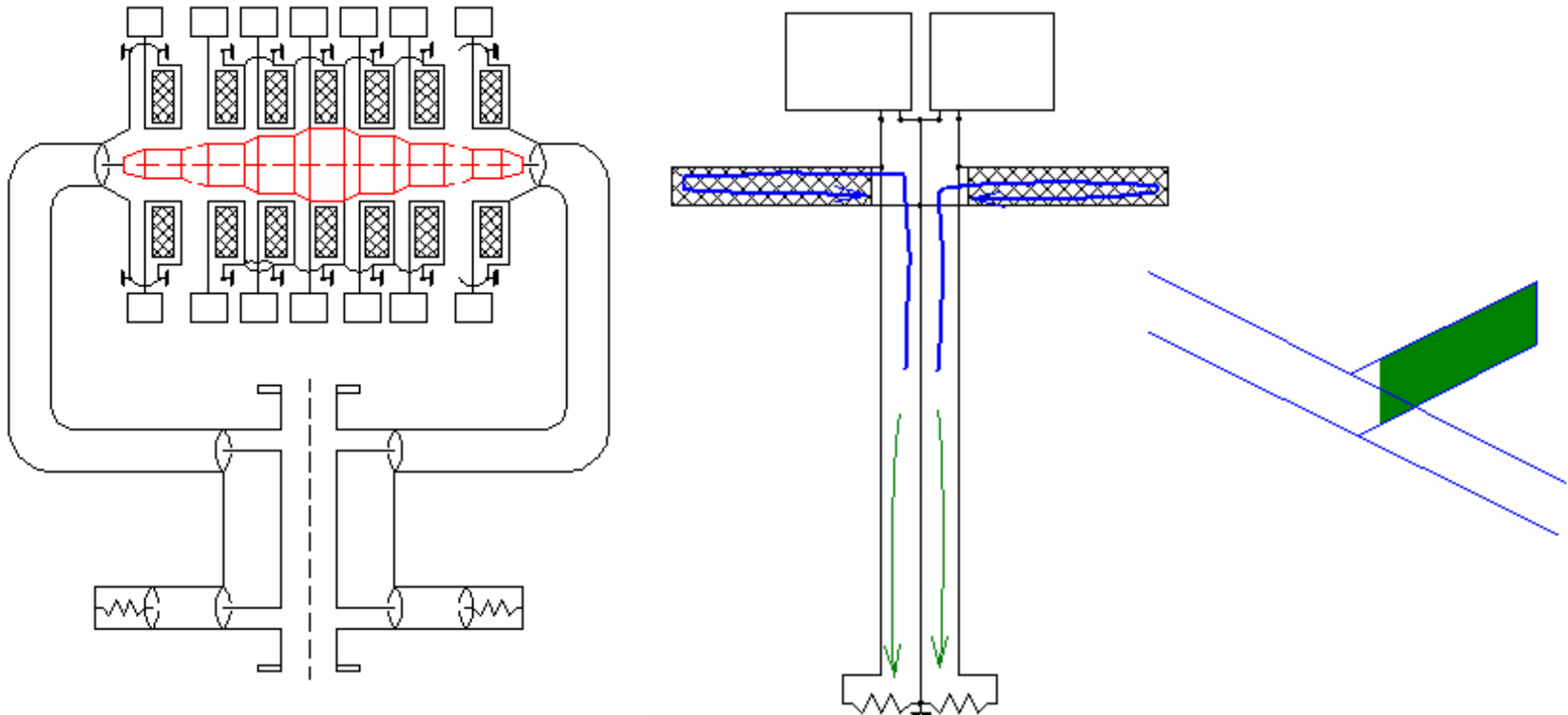

HOM power is extracted from the kicker and distributes along stacked induction cells. HOM power may be partly absorbed by the ferromagnetic. How much?

# 2.2 Other Known Topologies for the Pulser

Ideal Turn ON Switch

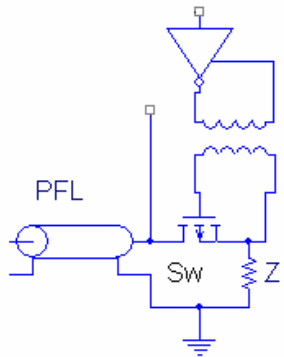

Ideal Turn OFF Switch

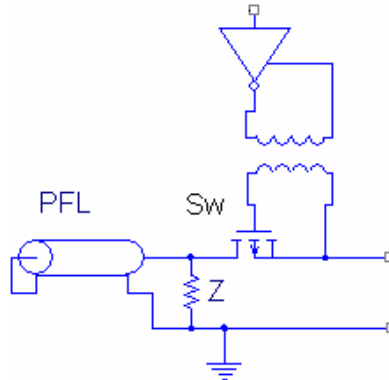

Classical Topology

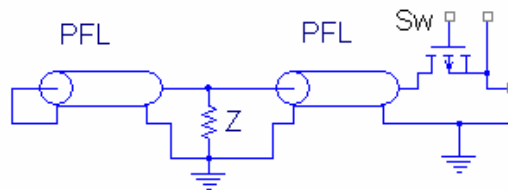
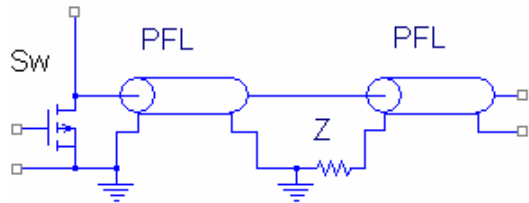

Blumlein Topology

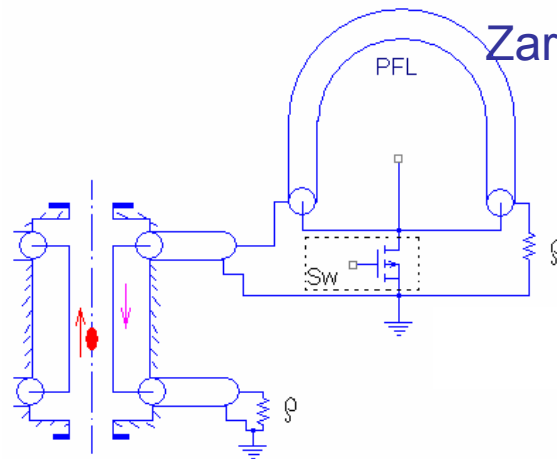
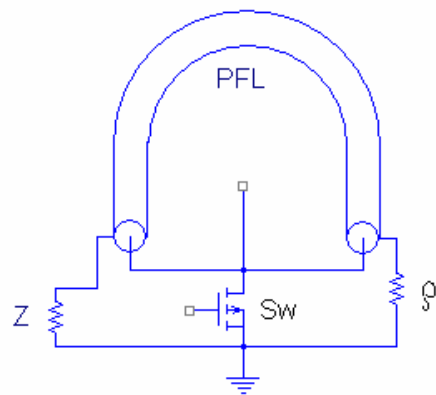

Zarem-Marshall-Hauser Topology

## 2.3 Classical Topology with ON or OFF Solid State Switch

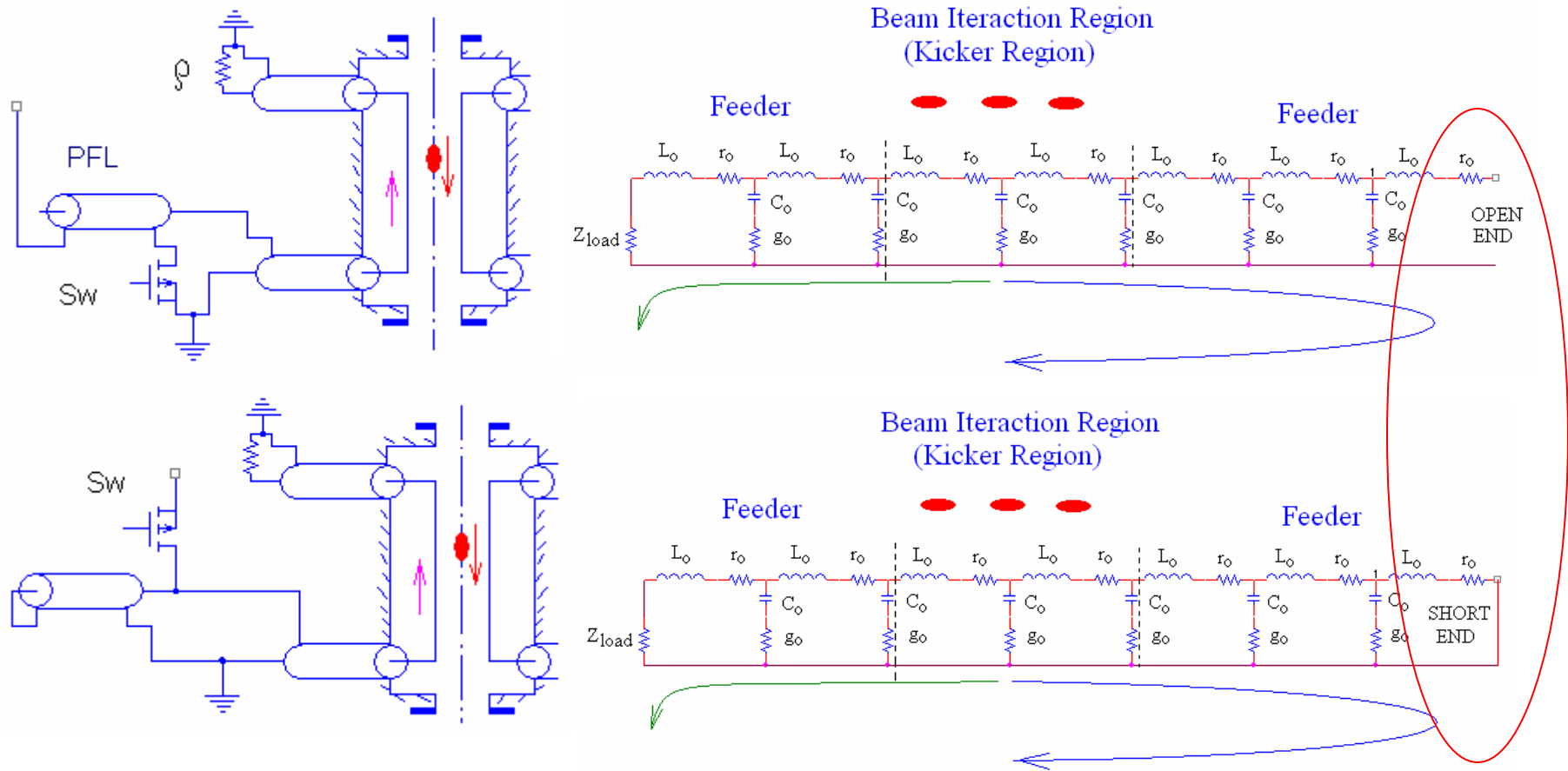

The feeder length between pulser and kicker region has to be a multiple length between nearest bunches for reflective cancellation. The feeder dispersion and dissipation as well as imperfect connections will leave the residual power in the active kicker region. The modulator can be a major source of the HOM power reflection (either OPEN or SHORT end)

## 2.4 Blumlein's Topology with ON and OFF Solid State Switch

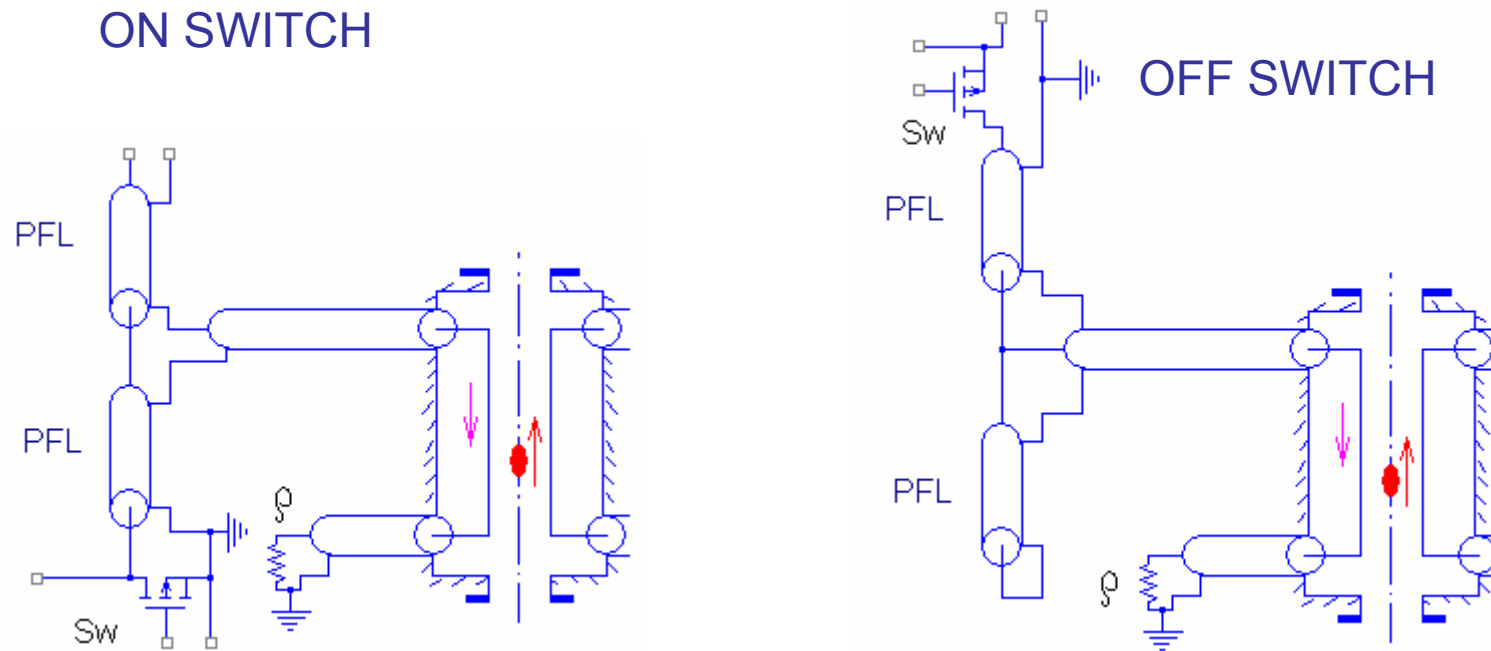

There are OPEN and SHORT ends in the Blumlein ON and OFF topologies. As result, the HOM conditions are practically the same as for the classical topology.

## 2.5 How can the HOM Issue be resolved?



$\sigma_z = 6 \text{ mm (20 psec)}$

$t_b = 2\text{RF periods (3.077 nsec)}$

$$\text{ratio} = \frac{3.077}{5 * 0.02} \cong 31$$

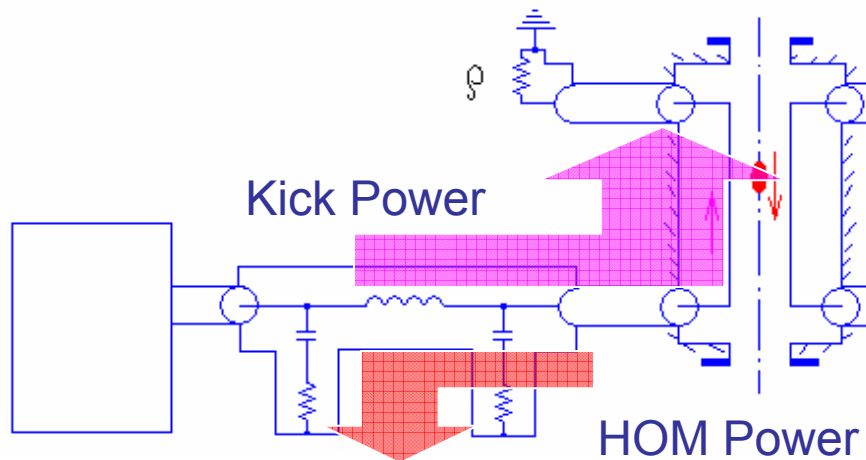

External HOM Absorber

Filtering of the HOM induced power is possible. However there are several issues that must be resolved:

-What is a realistic level of residual energy between bunches with HOM filters?

-Electric field pattern of residual power vs. the bunch pattern

- Where is the optimal position of HOM filter (in or out of tunnel)?

- What are the filter parameters and how they are realized (engineering problem)?

- Experimental study of filter would be necessary

## 2.6 Zarem-Marshall-Hauser Topology with ON Switch (Self-Matching Topology)

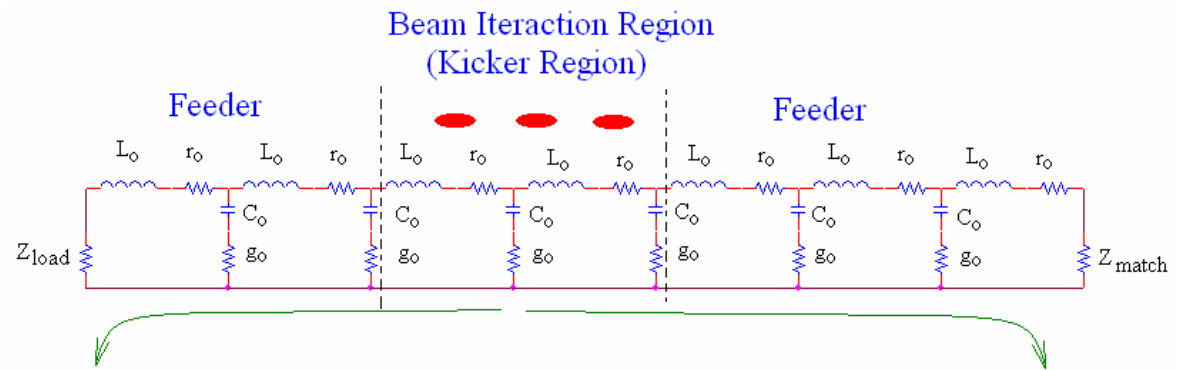
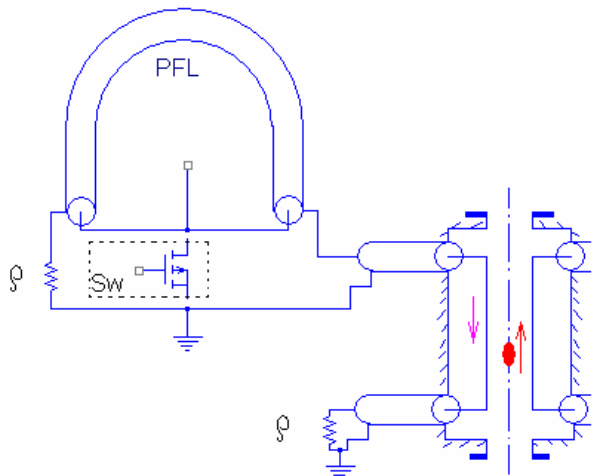

No filter is necessary to dump HOM power for the self-matching topology. However, even this topology will need experimental study. The real number of SWR of the feeder and load will influence the HOM residual energy. Reflections must be less than  $\sim 10^{-3}$  to meet the residual energy specification of  $7 \times 10^{-4}$  beyond 6 nsec after each pulse.

For example, this picture shows the consequence of the impedance discontinuity in the vacuum feedthrough of PEP-II TFB kicker

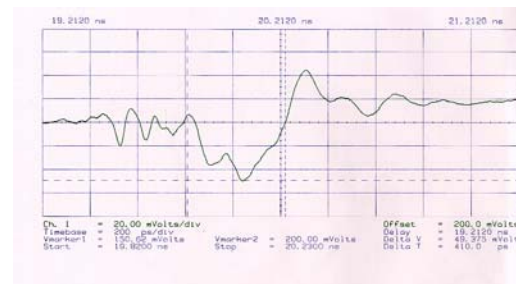

## 2.7 Summary of Topology Considerations

- The HOM absorbers between pulser and kicker must be properly designed



Result of the PEP-II TFB  
filter failure

Maybe the bunch orbit was  
set wrong?



## 2.7 Summary of Topology Considerations (cont.)

- Self-matching topology is more attractive. No high power filters are needed. However, the fastest solid state turn ON MOSFETs are too slow to generate the MW-level, 2 nsec pulse. Solid state Drift Step Recovery Devices can turn OFF the high power on sub-nanosecond time scales.
- Can a turn OFF self-matching circuit topology be developed for use with the DSRD switch?
- Minimize HOM power transmitted from the kicker to the pulser. The optimum kicker pulser topology and feeder length will be a function of the DR fill patterns.

# 3. Experimental Evaluation of the DSRD-based Pulser Topology

(performed at SLAC with Dr. A. Kardo-Sysoev)

## Experimental Objectives

- Experimentally demonstrate that the DSRD topology can produce a 2.0 nanosecond (FWHM ) HV pulse into a resistive load.
- Demonstrate the feasibility of producing a HV output pulse with a rise time of less than one nanosecond and a one nanosecond flat top.
- Evaluate methods to eliminate residual energy in the circuit (prevent post-pulses).

# 3.1 Experimental Setups



This is the DSRD structure made in St. Petersburg

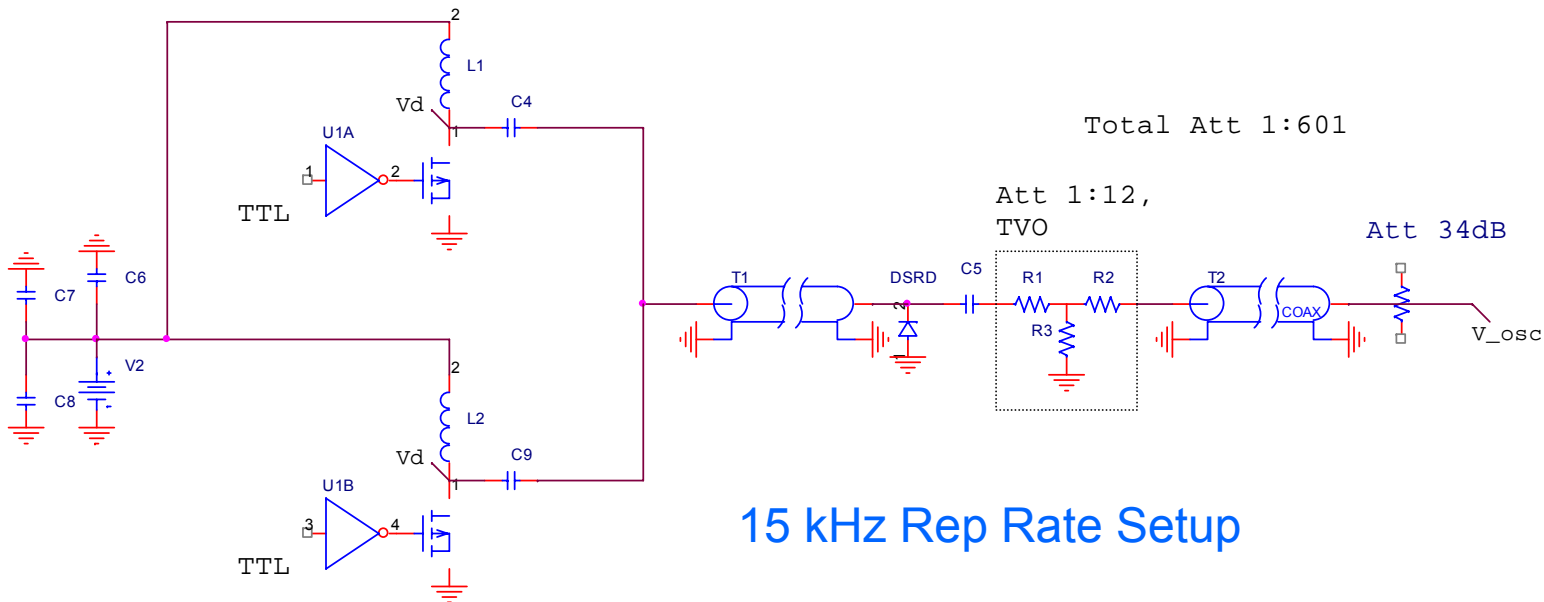
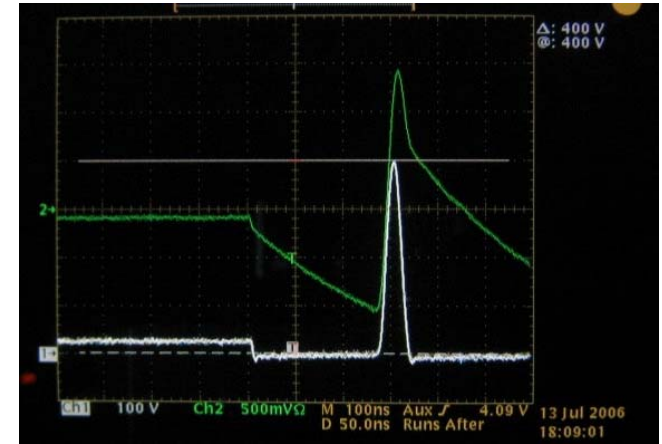
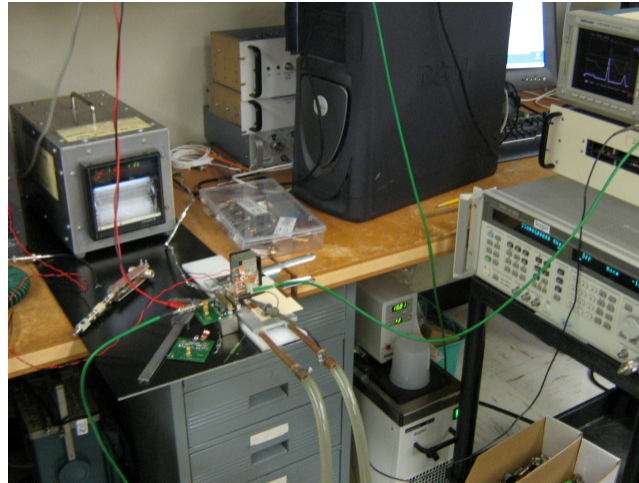

## 3.1 Experimental Setups (cont.)

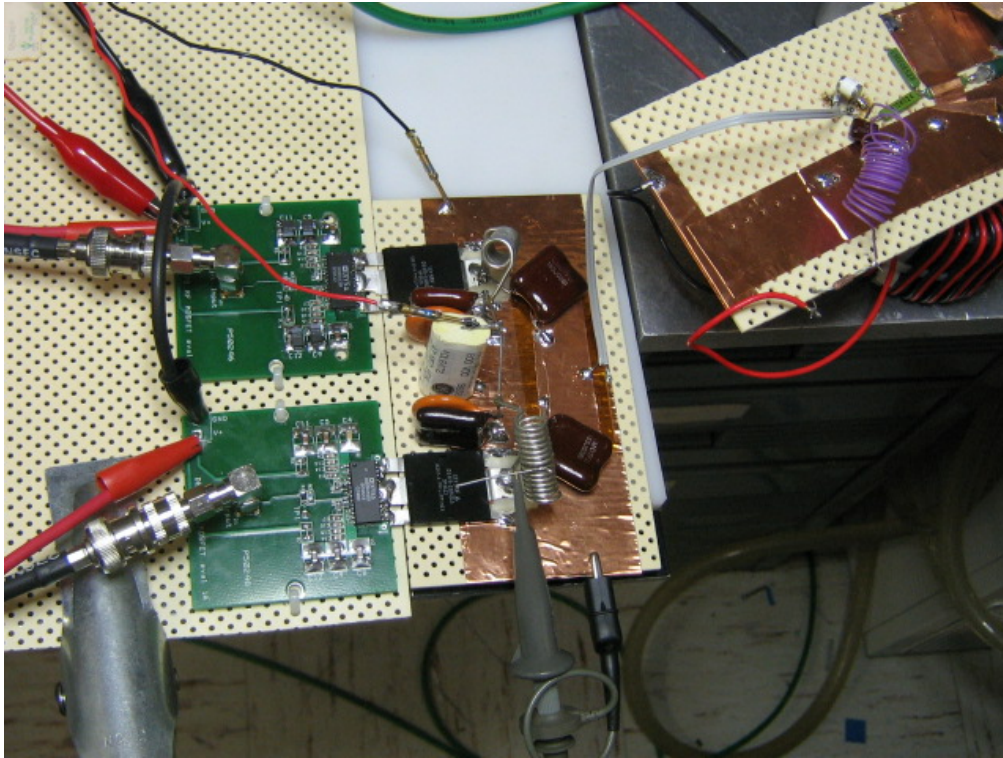

Rep Rate is up to 15 kHz.

No special cooling is necessary

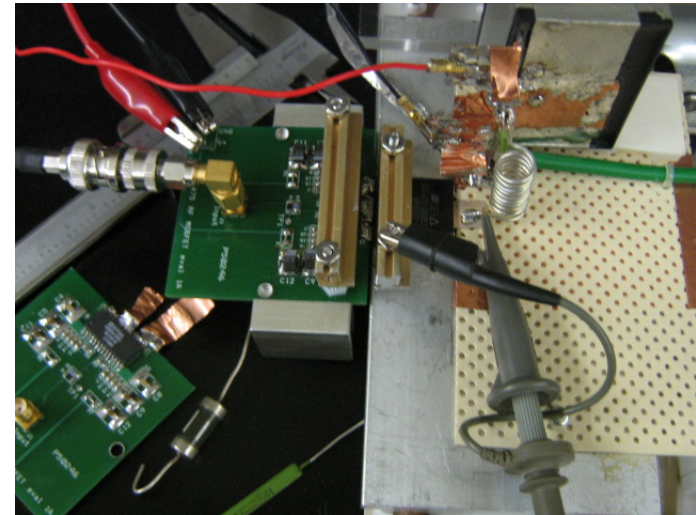

3MHz (CW) setup with the cooling system.

One driver and a DEI HV power MOSFET are mounted on a cooled water aluminum cold-plate

# Detailed Circuit Behavior (Model)

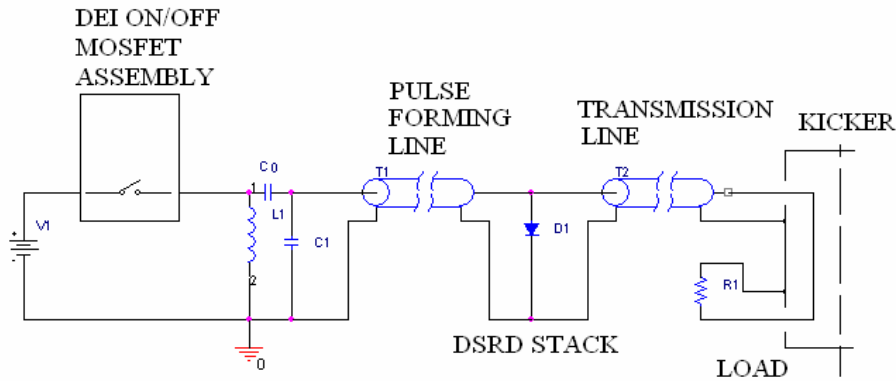

$L=40 \text{ nH}$ ,  $C_0=30 \text{ nF}$ ,  $C_1=1.5 \text{ nF}$ ,  
 $t_{on}=150 \text{ nsec}$

3 MHz Rep Rate

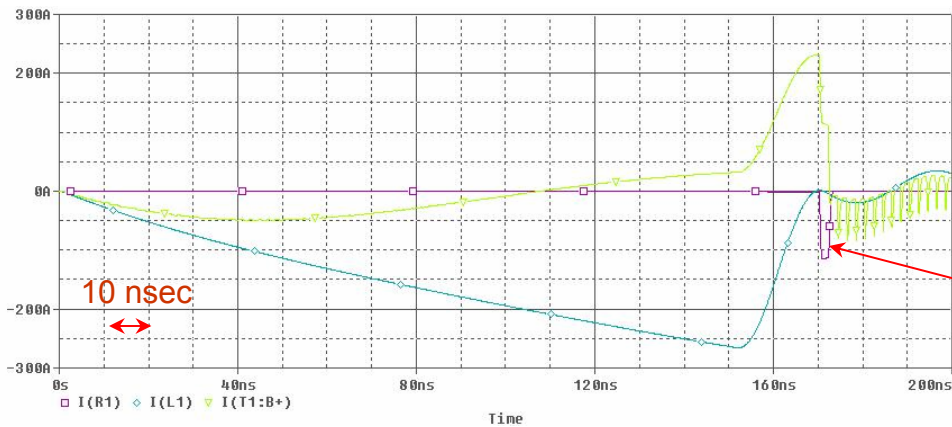
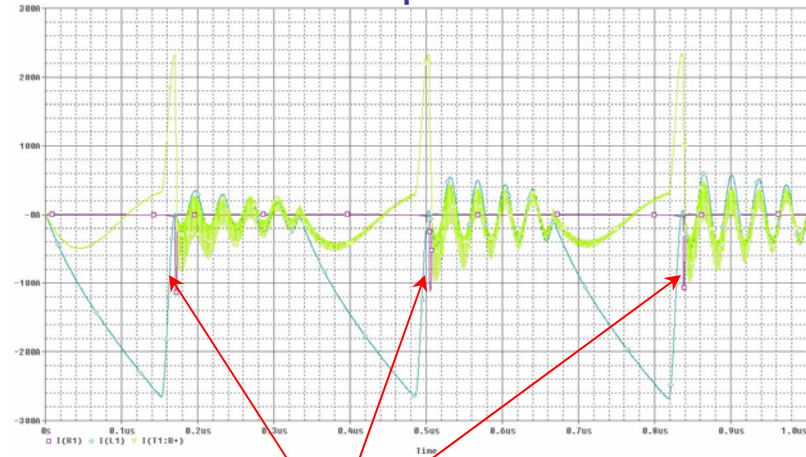

Currents vs. time for one cycle

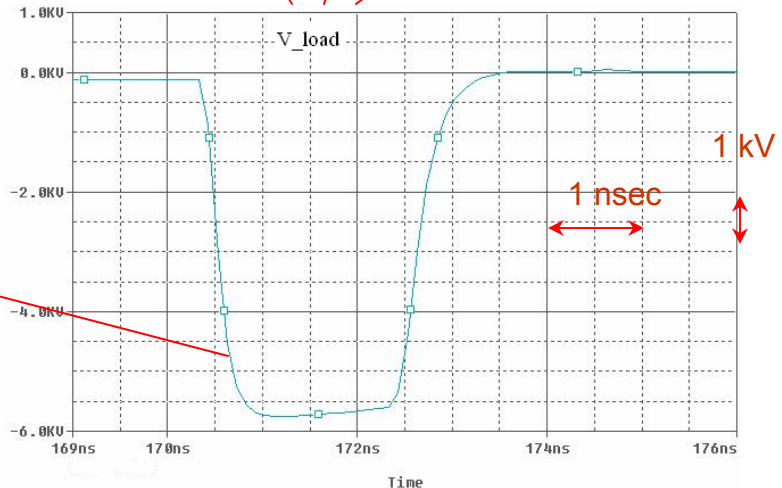

Output Voltage, Residual Voltage is  $\sim 2\%$

# 3.2 Transmission Lines for DSRD –based Experiments

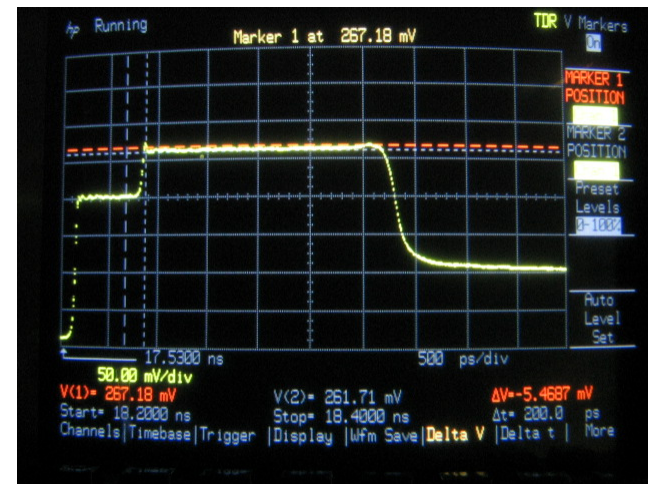
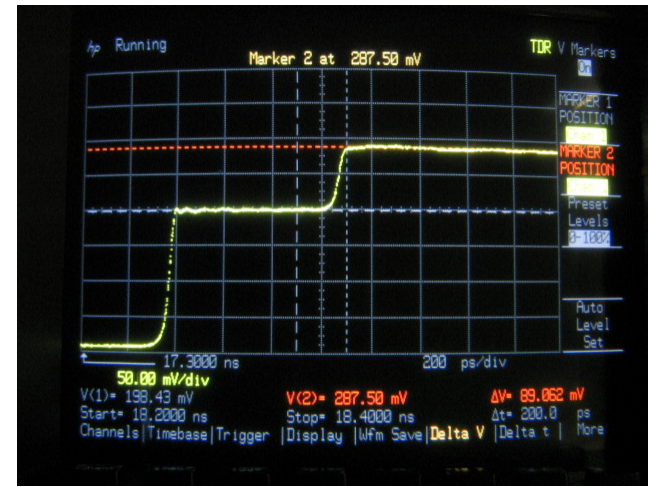

R	0.449092742	R	0.315020161	R	0.534274194
1-R	0.550907258	1-R	0.684979839	1-R	0.465725806
1+R	1.449092742	1+R	1.315020161	1+R	1.534274194
Imped	131.5187557	Imped	95.98969831	Imped	164.7186147
v	10.65	v	10.65	v	10.65
c	30	c	30	c	30
eps	7.934933545	eps	7.934933545	eps	7.934933545
CO	7.13942E-11	CO	9.78196E-11	CO	5.70043E-11
LO	1.23492E-06	LO	9.01312E-07	LO	1.54665E-06
L, cm	10.65	L, cm	10.65	L, cm	10.65
C, pF	7.603478261	C, pF	10.41778459	C, pF	6.070959264
L, nH	131.5187557	L, nH	95.98969831	L, nH	164.7186147

A 50 Ohm coax cable will be used for a pulser. Two-wire lines are employed in our experiments.

# 3.3 Output Voltages vs. Tuning Procedure

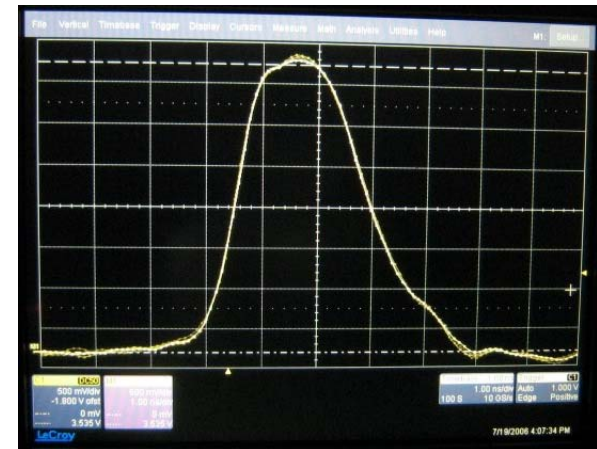
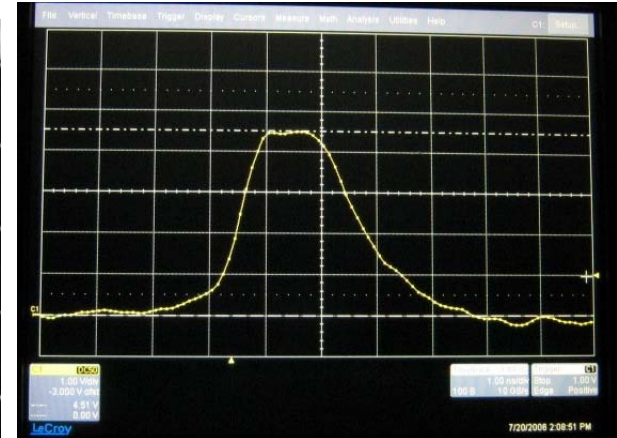
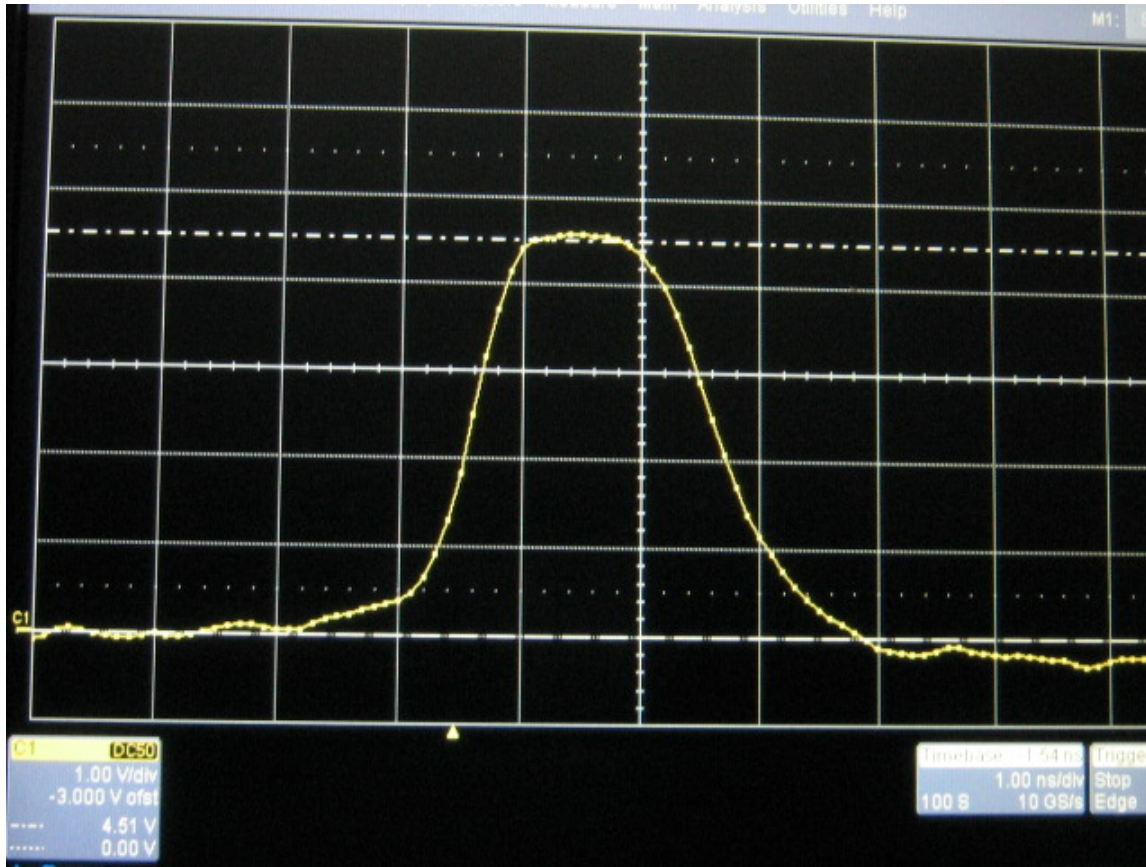

$A_{out} = 4.5 \times 600 = 2,700 \text{ V}$   
Horizontal scale: 1 ns / div  
(LeCroy oscilloscope @ 10GS/sec)

Design Spec:  $A_{out} +_5 \text{ kV}$  at 50 Ohm,  
(kick is 142 keV per 30 cm),  
pulse plateau is 2 nsec

# 3.5 Residual Energy Control

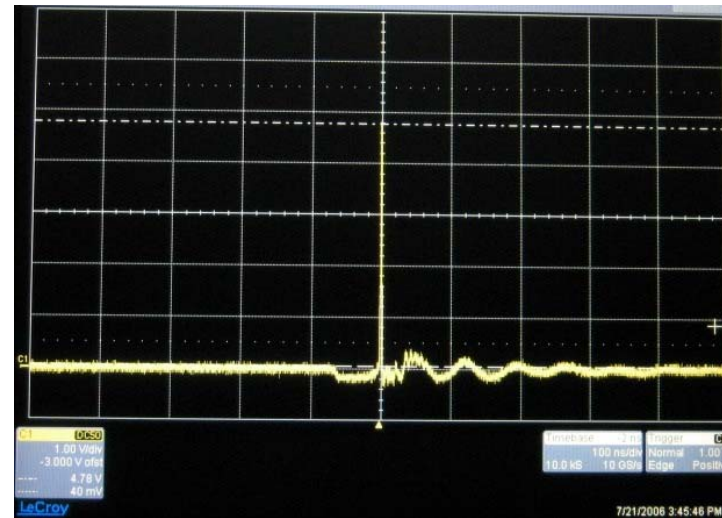
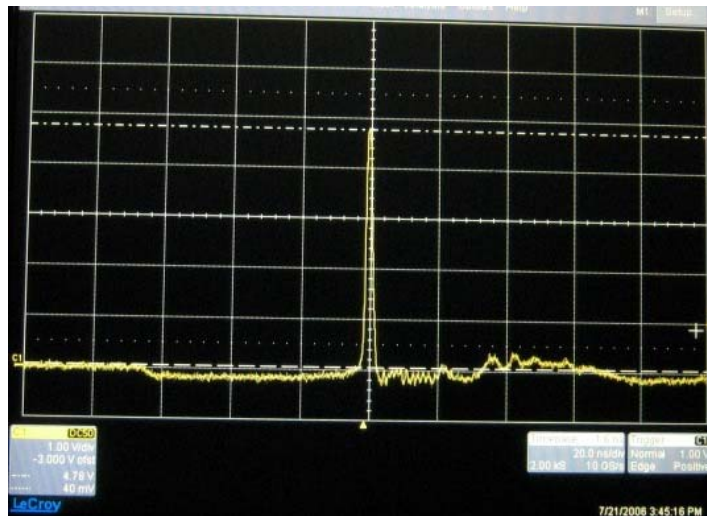
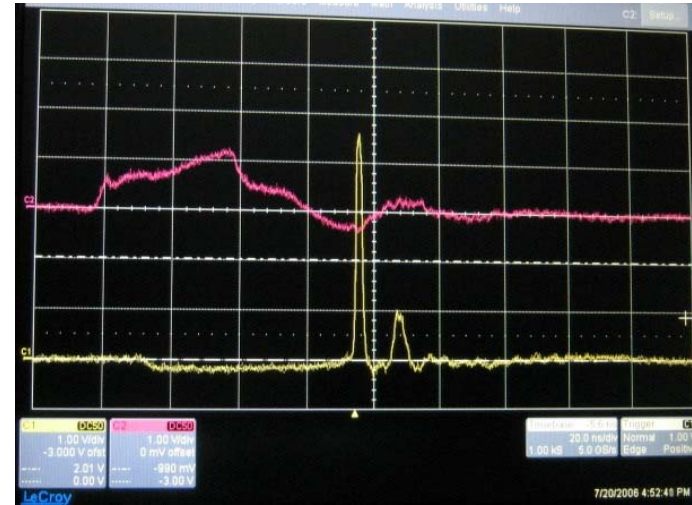
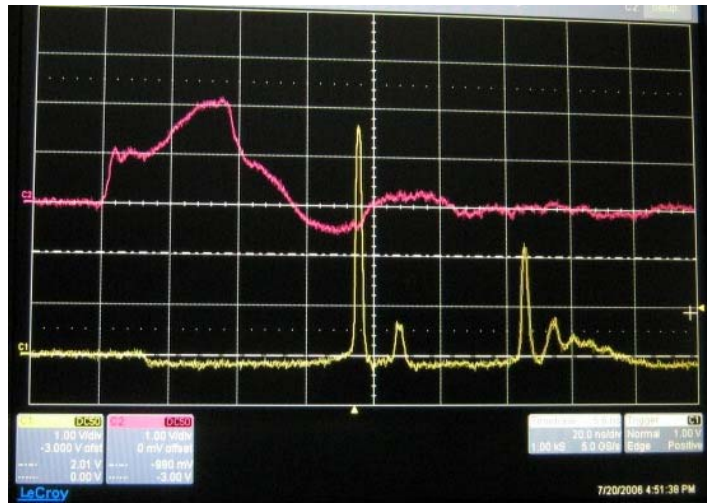



## 4. Kicker Electrodynamics: Development of a reduced beam impedance kicker structure

Even and Odd modes

Kicker Directivity

Kicker End Effects

Kicker Components (feedthrough, electrodes, etc.)

Kicker Assembly (proposal)

# Kicker Electrodynamics



Report on the Kicker Design  
for ILC Damping Rings

*SLAC, March 23, 2005*

A. Krasnykh

Some “Hot Aspects”  
for ILC DR Kicker Design

For Mini Kicker Work Shop in KEK

by

A. Krasnykh (SLAC)

Two previous presentations cover the design status of the kicker structure in general and the major features of the proposed kicker for the ILC DR.

# General Features for MODEL-01

## MODEL-01: Field Distribution Near Axis

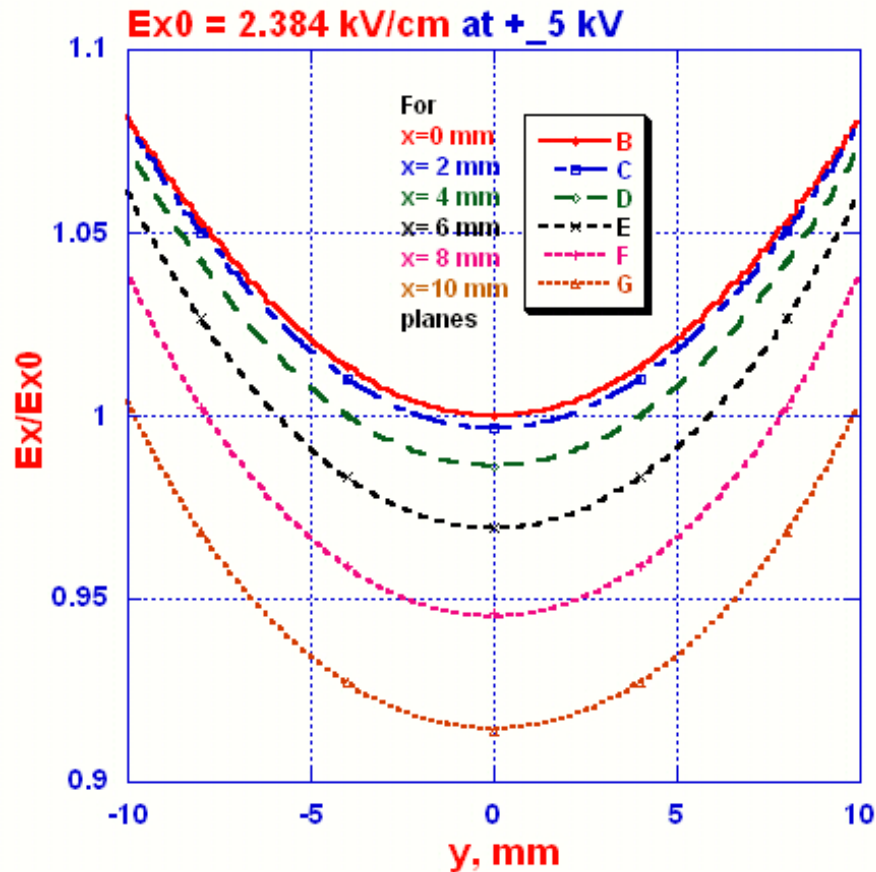

- If injecting e+ beam radius is 8 mm, the max field perturbation is  $\sim 5\%$
- The electrode voltage  $+_5$  kV produces the electric gradient 2.384 kV/cm on the z-axis
- The expected electromagnetic kick is 4.75 keV per one cm of the kicker length. For 1 nsec electrode length the transverse kick is 142 keV and the necessary pulse plateau is 2 nsec
- The kicker current per each electrode is  $\sim 100$  A @ 5 kV pulse
- The TEM-mode impedance for the beam induced field is 63.9 Ohm, coupling between electrodes is 0.162. The reflection coefficient is 0.12

Electrode shaping may improve the field homogeneous if required. There is a tradeoff between the field uniform and the degree of mismatch.

# Kicker Electrodynamics: Even/Odd Mode

Proposed Cross Section of the ILC DR Kicker

MODEL-01

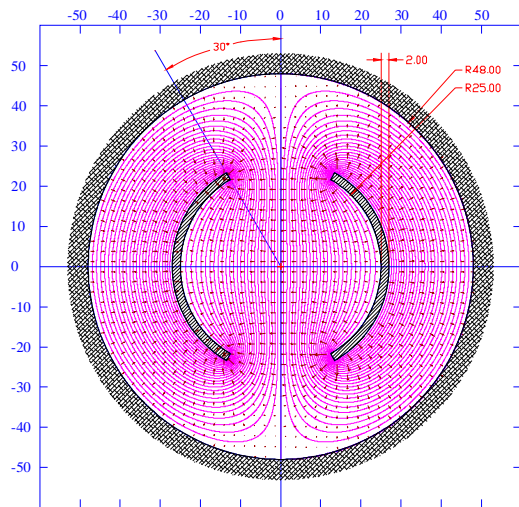

Geometry:

- Inner Housing Diameter is 96 mm \*)
- Inner Electrode Diameter is 50 mm
- Electrode Thickness is 2 mm
- Swept Electrode Angle is 120 Deg

\*) Standard tube OD=4" with wall thickness 0.125" could be used for a mockup

*Electric Field Pattern for Differential (or Odd) TEM-mode*

**Differential TEM- mode  
Impedance is 49.5 Ohm**

Proposed Cross Section of the ILC DR Kicker

MODEL-01

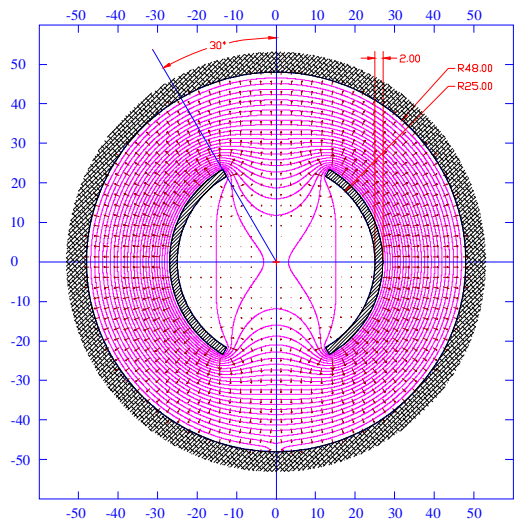

Geometry:

- Inner Housing Diameter is 96 mm \*)
- Inner Electrode Diameter is 50 mm
- Electrode Thickness is 2 mm
- Swept Electrode Angle is 120 Deg

\*) Standard tube OD=4" with wall thickness 0.125" could be used for a mockup

*Electric Field Pattern for Common (or Even) TEM-mode \*)*

**Common TEM-mode  
Impedance is ..... 63.9 Ohm  
Coupling coefficient is ... 0.162**

\*) Electric field of the bunch does not shown

A pulser produces a transverse kick. The difference (or odd) TEM mode is excited.

When the bunch passes a kicker structure it induces an effectively even (or sum) TEM-mode.

The field patterns for modes are dissimilar. As a result the impedances are different. Interferes with removing HOM energy from the structure

# Kicker Electrodynamics: Even/Odd Mode

Proposed Cross Section for the ILC DR Kicker

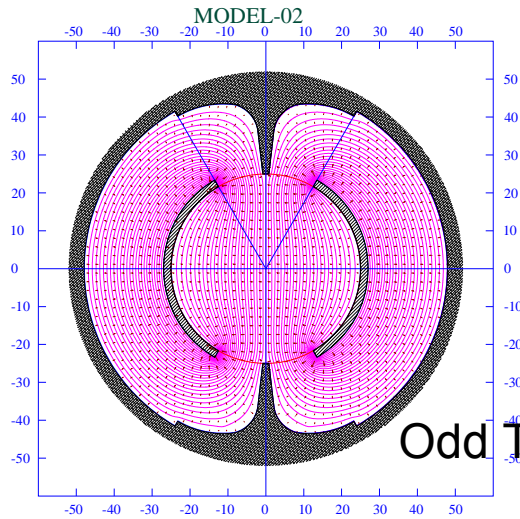

Odd TEM-mode,  $Z=49$  Ohm

Matching both impedances is possible by the introduction of the ground fenders.

Proposed Cross Section for the ILC DR Kicker

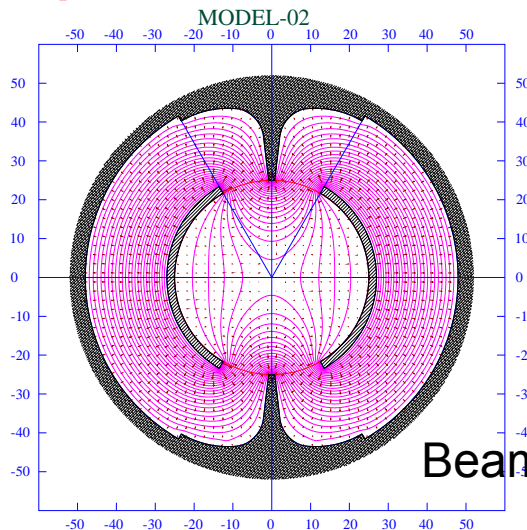

Beam induced even TEM-mode,  $Z=55$  Ohm

Additional fenders will reduce the beam impedance and will help the DR beam dynamics.

# Comparison of Model-01 and Model-02 for the Even Mode

Proposed Cross Section for the ILC DR Kicker

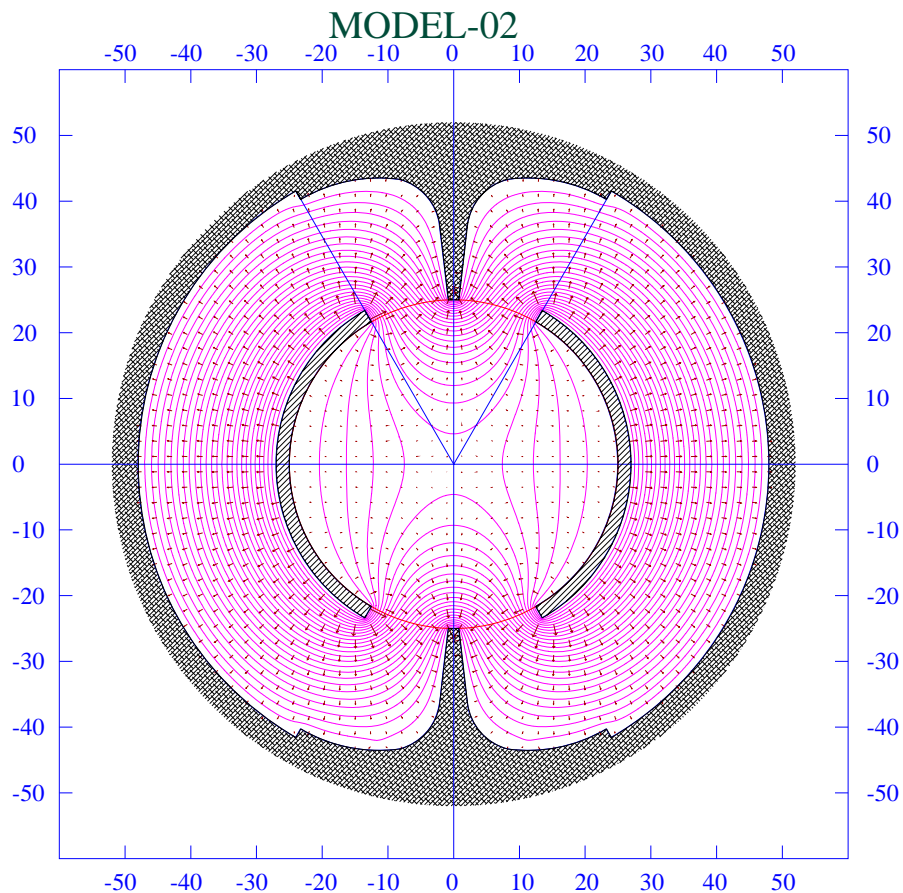

	Model01	Model02
Z_even	63.9	55.0
Coupling	0.162	0.113
Reflection	0.122	0.048

# Kicker Electrodynamics: Even/Odd Mode

Condition, when ODD and EVEN modes are necessary to take into account, is rather simple.

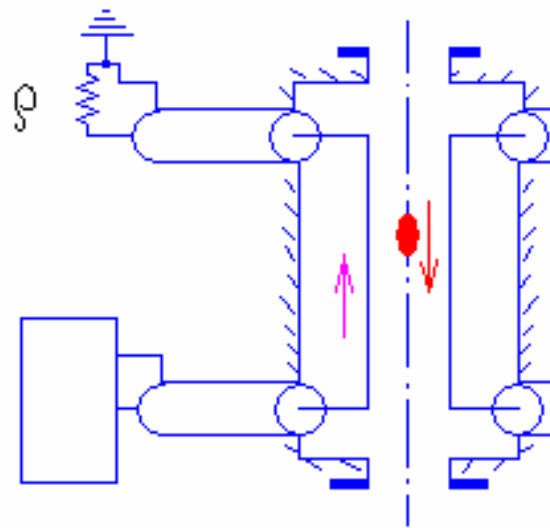

$$L > c * t_{\text{rise\_or\_fall}}$$

$$L > c * \sigma_{\text{bunch}}$$

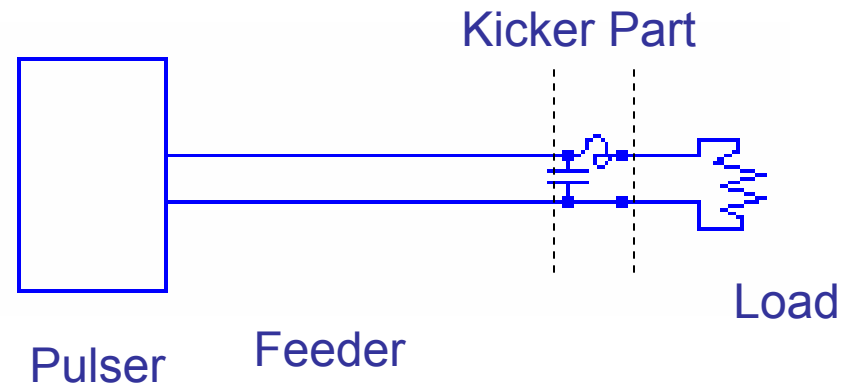

# Directivity: Mismatch

Pulser sees one impedance but the beam induced wave sees another one. The difference in impedances is one source of mismatch.

Pulser produces positive and negative amplitudes. A pulse asymmetry (amplitude or timing) is another source of mismatch.

The mismatch is a source of residual energy in the kicker structure. The remaining energy may act on the following bunches. The residual energy is proportional to the number of stored bunches and inversely proportional to the space between bunches, i.e. a residual energy has the fill pattern dependency.

The mismatch is a source of energy that propagates back to the pulser, i.e. the perfect kicker directivity is broken. Protection of pulser is necessary.



# Directivity: Kicker End Effects

➤ Example is based on experimental results from PEP-II

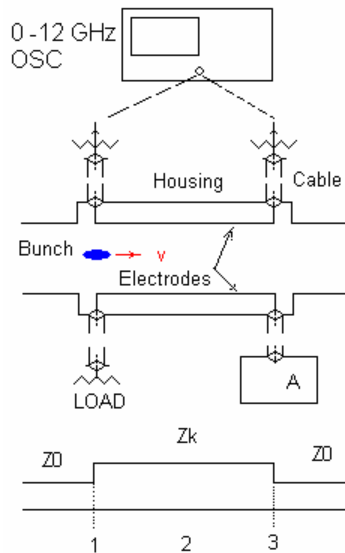
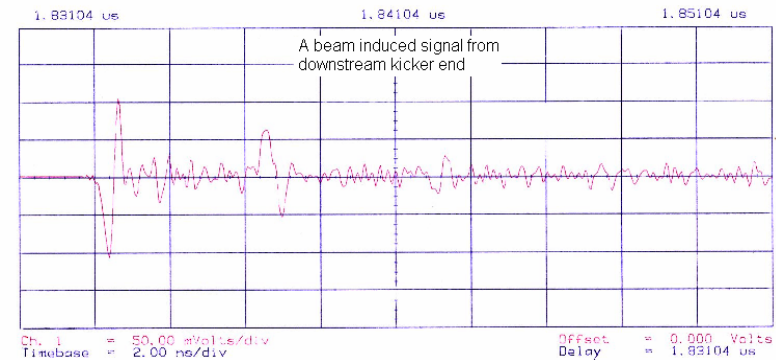
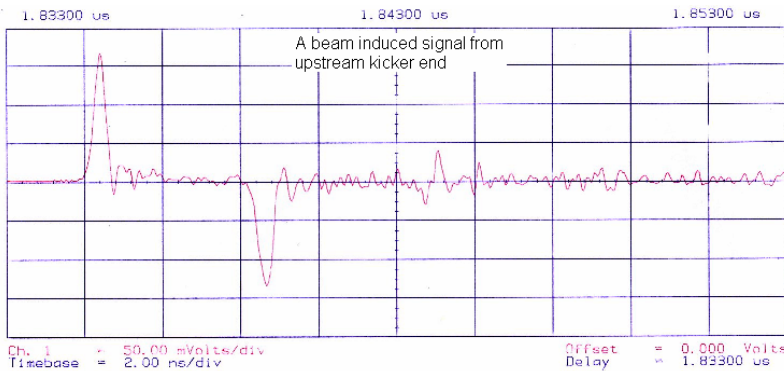

Beam induced power is in both feeders !!!

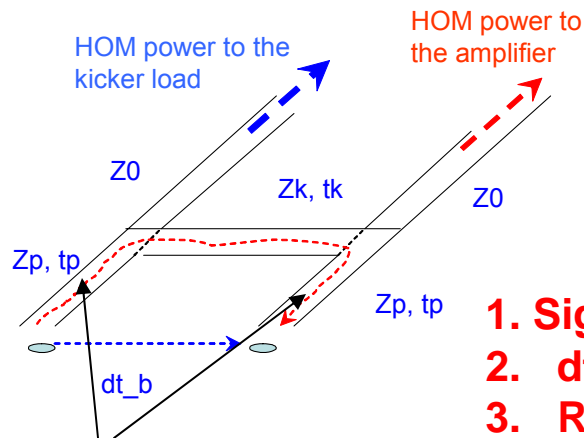

Paddles regions

HER, single bunch 0.8mA, 16.5 MV, att=26dB

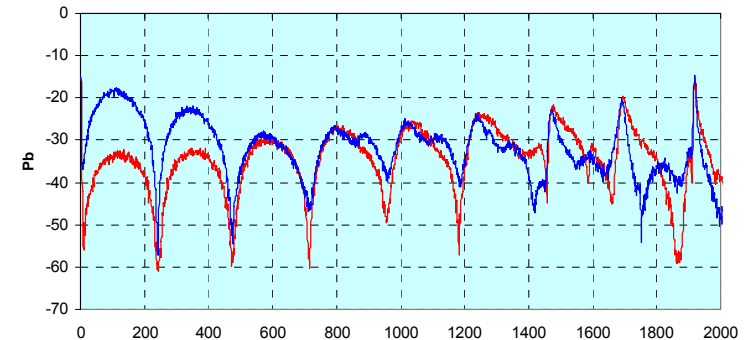

1.  $\Sigma_{beam} < dR$  (condition)
2.  $dt_b < 2t_p + t_k$  (cause)
3. Reflection on the ( $Z_0, Z_p, Z_k$ ) nodes (cause)
4. Dissipation in kicker electrodes (effect)

# Loss of Directivity: HOM Simulations (single bunch)

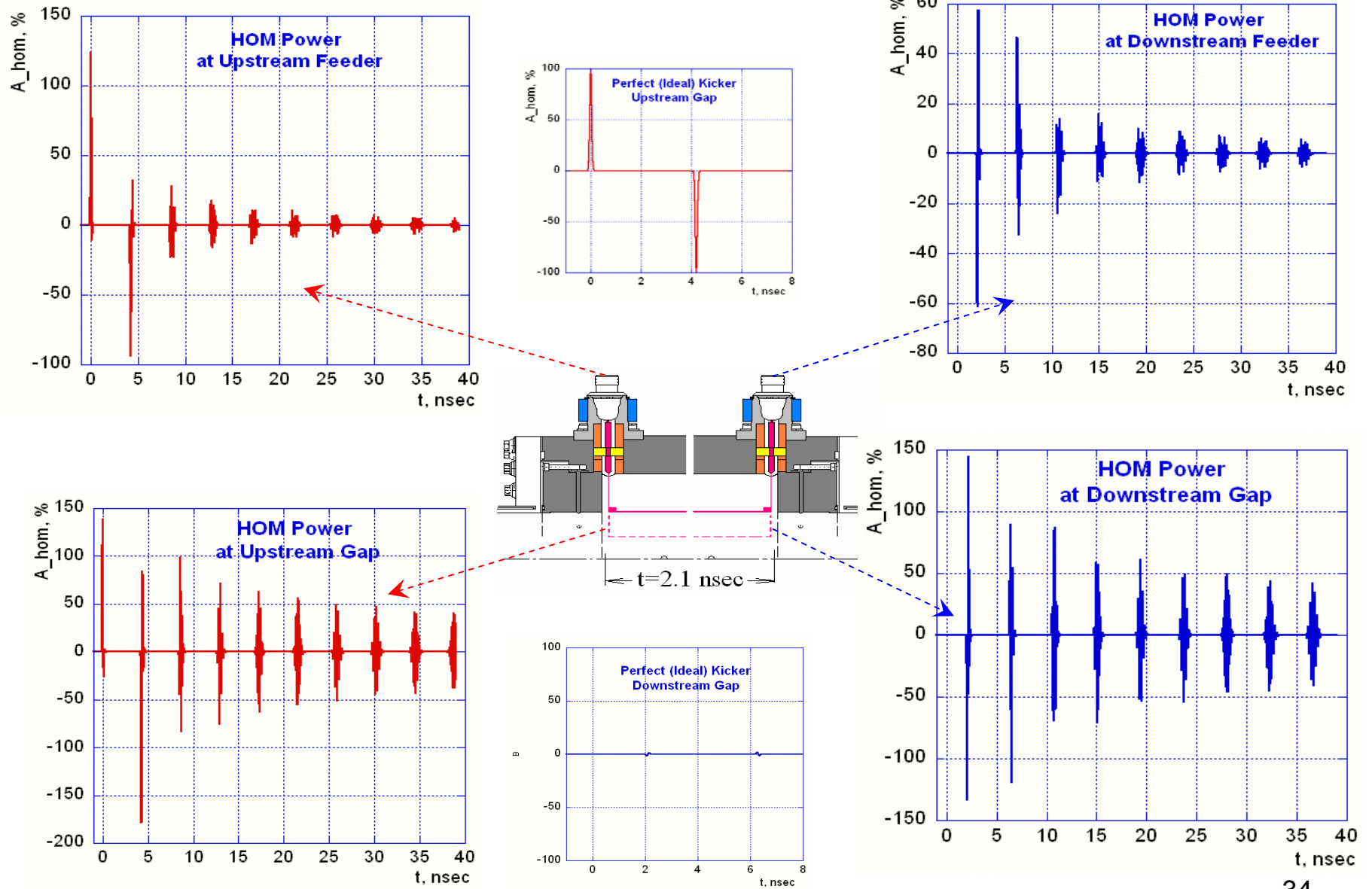

# HOM Power Induced Tearing Modes

Result of Simulation of Kicker End Effect for the Second Following Bunch

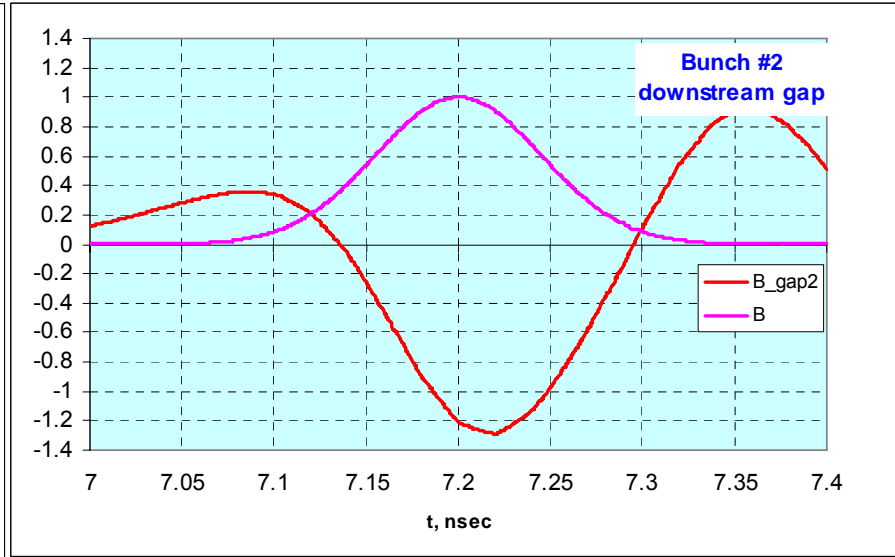
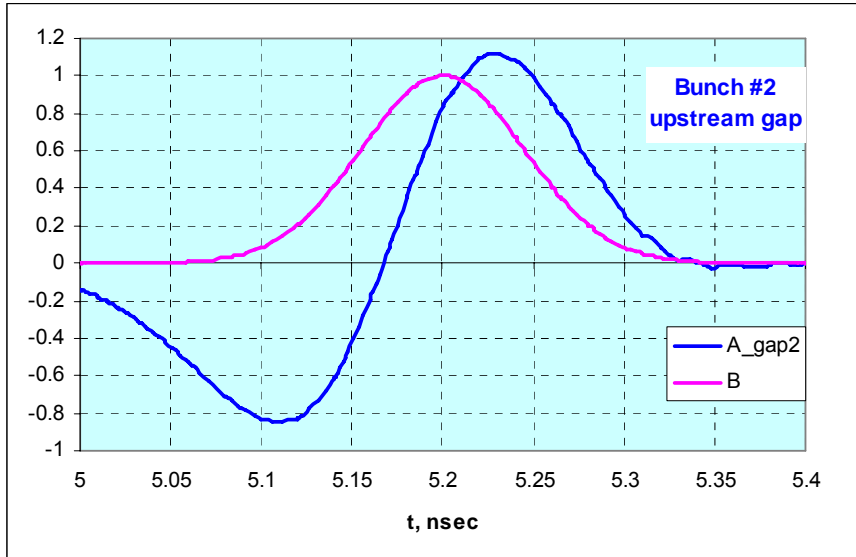

## Summary of Kicker Electrodynamics

- Even and odd TEM-modes: differing impedances
- Effects related to the kicker impedance mismatches: breaks directivity
- Kicker end effects produce the longitudinal momentum that apparently can be damped by the longitudinal feedback

# Kicker Components (feedthrough, electrodes, etc.)

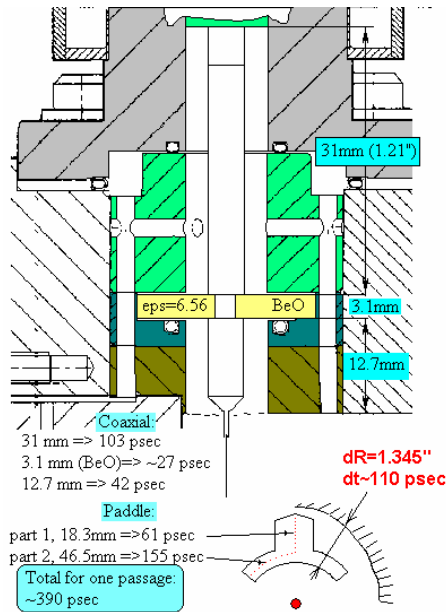

## TDR of TFB PEP-II Feedthrough

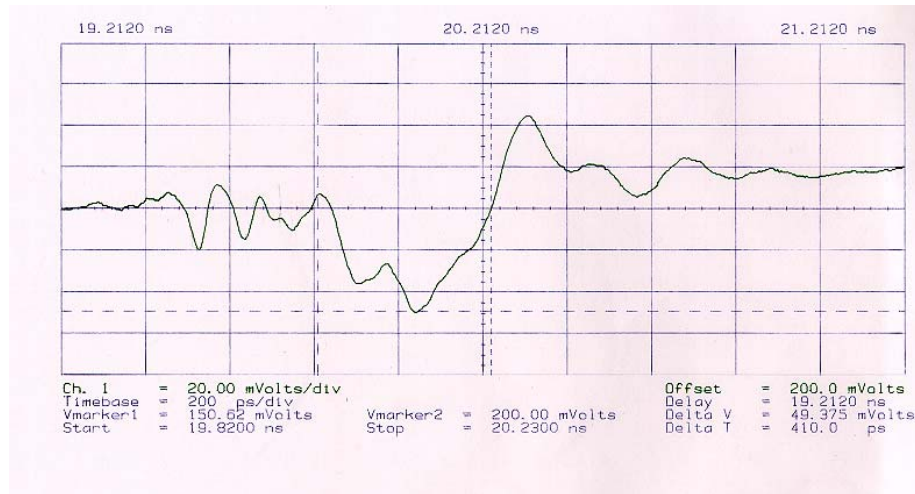

## TDR of ATF DR Kicker Feedthrough

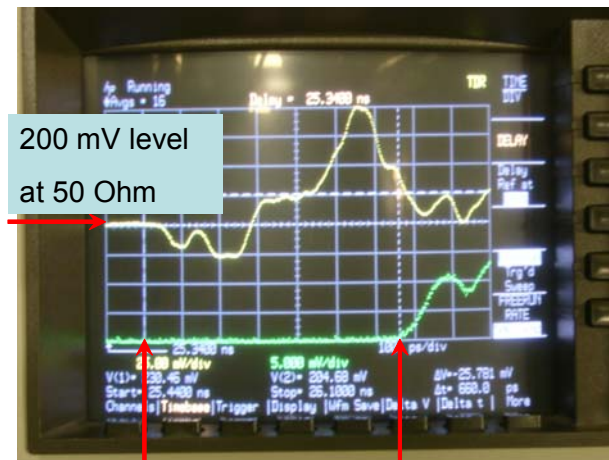
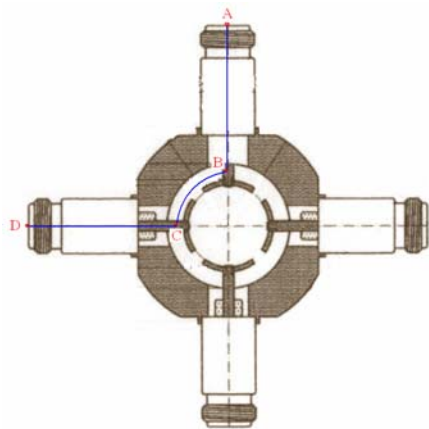

Reflection is ~10 Ohm/div

# ILC DR Kicker Assembly (proposal)

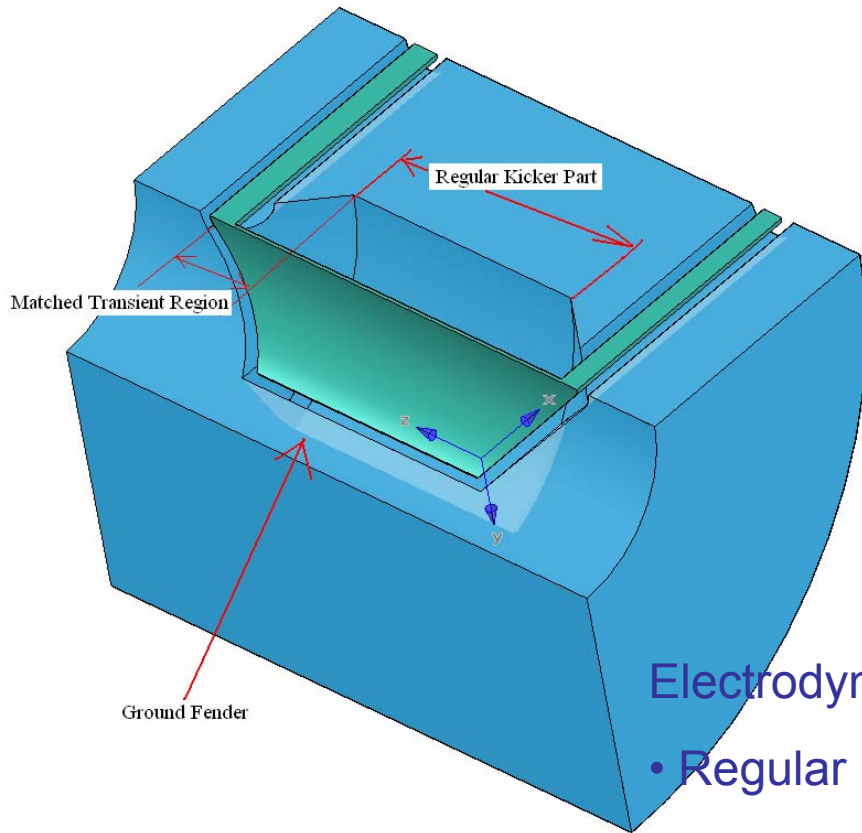

Quarter of Model is shown

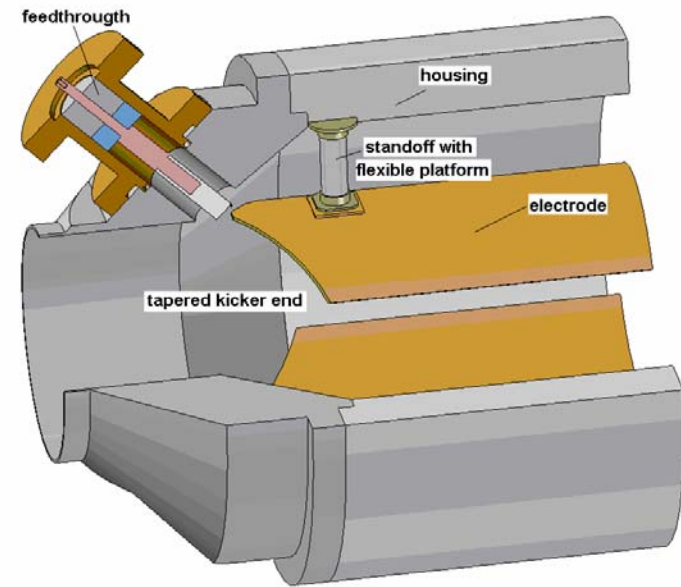

Electrodynamic Structure with:

- Regular Kicker Part
- Two Matched Transition Regions at the Kicker Ends
- Ground Fenders
- Broadband Constant Impedance Feedthrough

# Summary of the Reduced Beam Impedance Kicker

- Field distribution in the 10 mm x 10 mm aperture has been obtained. The maximum field perturbation in the current design is ~ 5%.
- New kicker element: Ground Fenders were placed into kicker. Fenders reduce reflections for EVEN mode and little impact on the ODD mode impedance. Another advantage of the kicker with ground fenders is a reduction of the beam impedance.
- PEP-II TFB kicker is a good prototype for the ILC DR injection/extraction kicker. However the HOM power simulation of the PEP-II TFB kicker shows that the residual energy bounces between kicker ends many times. The time decay is rather slow and it is a function of the kicker design, particularly end effects. The proposed ILC DR kicker design will minimize these effects.

# Acknowledgements

- Work is supported partly by Department of Energy contracts DE–AC02–76SF00515 and partly by the DTI SBIR grant DE-FG02-06ER84459 “Fast Kicker Driver for ILC DR”
- The DSRD proposal and experiments were carried out together with Dr. Alexei Kardo-Sysoev (Ioffe PTI, St. Petersburg, Russia), who is the DSRD structure inventor
- The experimental results on the PEP-II TFB kicker were performed together with Ronald Akre (SLAC) and Uli Wienands (SLAC)
- The KEK ATF DR kicker studies were performed with Marc Ross (SLAC) and Takashi Naito-san (KEK)
- The author thanks Craig Burkhardt (SLAC) for making this presentation.
- The author would welcome comments and critiques from the attendees ([krasnykh@slac.stanford.edu](mailto:krasnykh@slac.stanford.edu))