

REVISIONS				
SYM.	ZONE	DESCRIPTION	DATE	APP.
A		UPDATED ASSEMBLY VIEWS	6/2/03	Y.H.

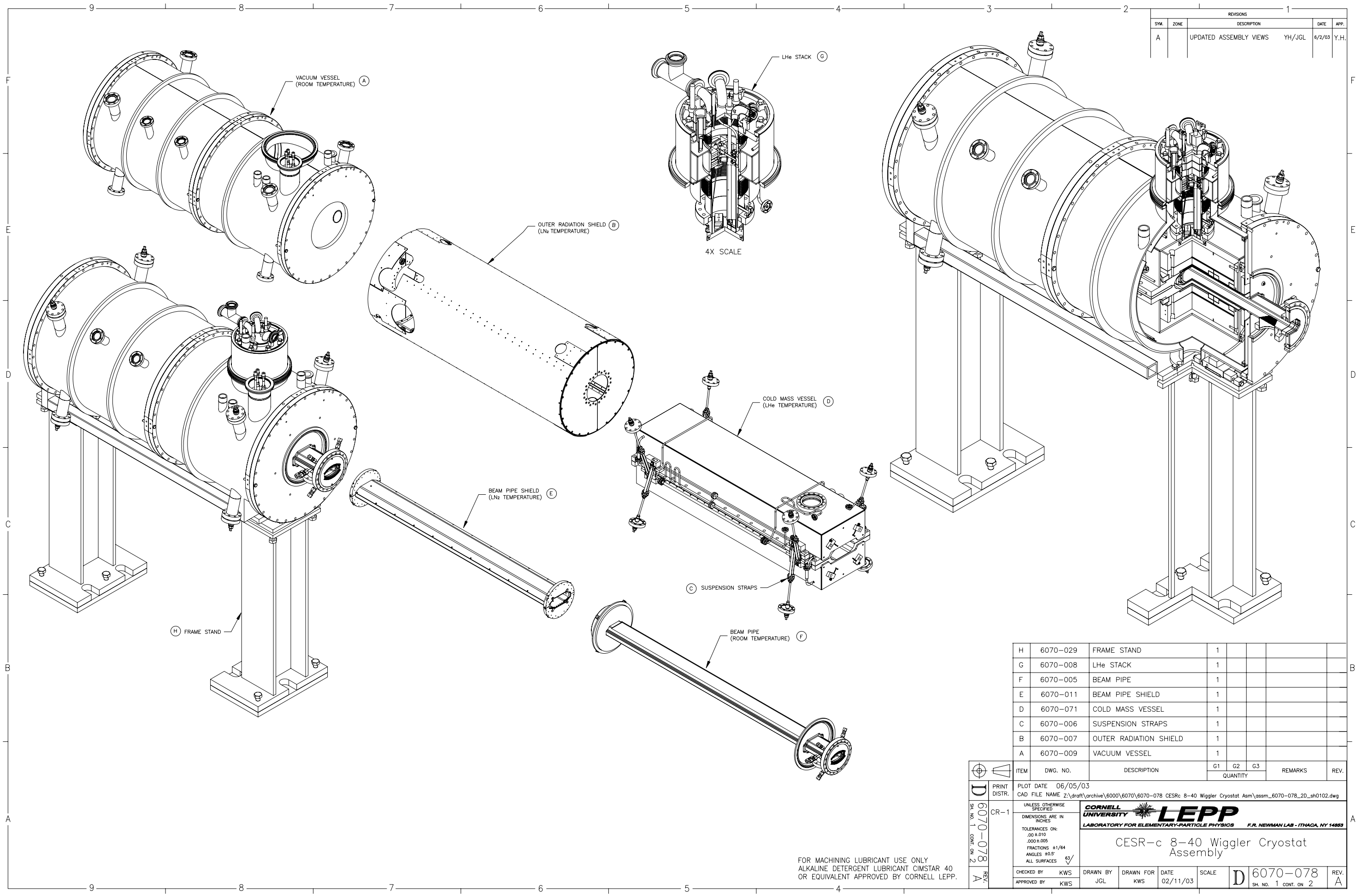

ITEM	DWG. NO.	DESCRIPTION	G1	G2	G3	REMARKS	REV.
H	6070-029	FRAME STAND	1				
G	6070-008	LHe STACK	1				
F	6070-005	BEAM PIPE	1				
E	6070-011	BEAM PIPE SHIELD	1				
D	6070-071	COLD MASS VESSEL	1				
C	6070-006	SUSPENSION STRAPS	1				
B	6070-007	OUTER RADIATION SHIELD	1				
A	6070-009	VACUUM VESSEL	1				

D	PRINT DISTR.	PLOT DATE 06/05/03	CORNELL UNIVERSITY LEPP LABORATORY FOR ELEMENTARY-PARTICLE PHYSICS F.R. NEWMAN LAB - ITHACA, NY 14853
	CR-1	CAD FILE NAME Z:\draft\archive\6000\6070\6070-078 CESRc 8-40 Wiggler Cryostat Asm\assm_6070-078_2D_sh0102.dwg	
6070-078	SH. NO. 1 CONT. ON 2	UNLESS OTHERWISE SPECIFIED DIMENSIONS ARE IN INCHES	
		TOLERANCES ON: .00 ±.010 .000 ±.005 FRACTIONS ±1/64 ANGLES ±0.5° ALL SURFACES	
REV. A	CHECKED BY KWS	DRAWN BY JGL	DATE 02/11/03
	APPROVED BY KWS	DRAWN FOR KWS	SCALE D

FOR MACHINING LUBRICANT USE ONLY
ALKALINE DETERGENT LUBRICANT CIMSTAR 40
OR EQUIVALENT APPROVED BY CORNELL LEPP.

CESR-c 8-40 Wiggler Cryostat
Assembly

REV. A
SH. NO. 1 CONT. ON 2

REVISIONS				
SYM.	ZONE	DESCRIPTION	DATE	APP.
A		UPDATED ASSEMBLY VIEWS & ADDED SHEET #3	6/2/03	Y.H.

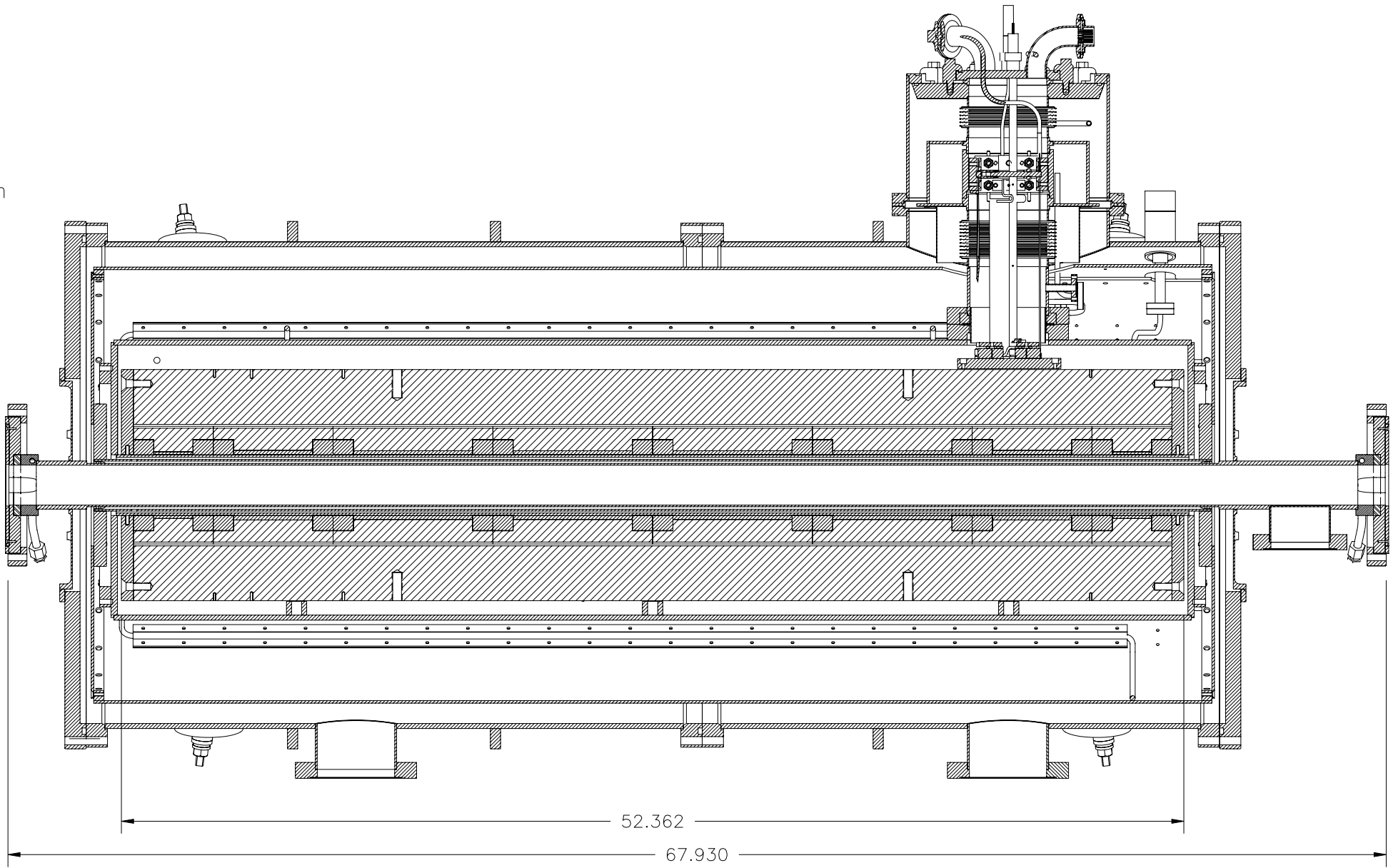
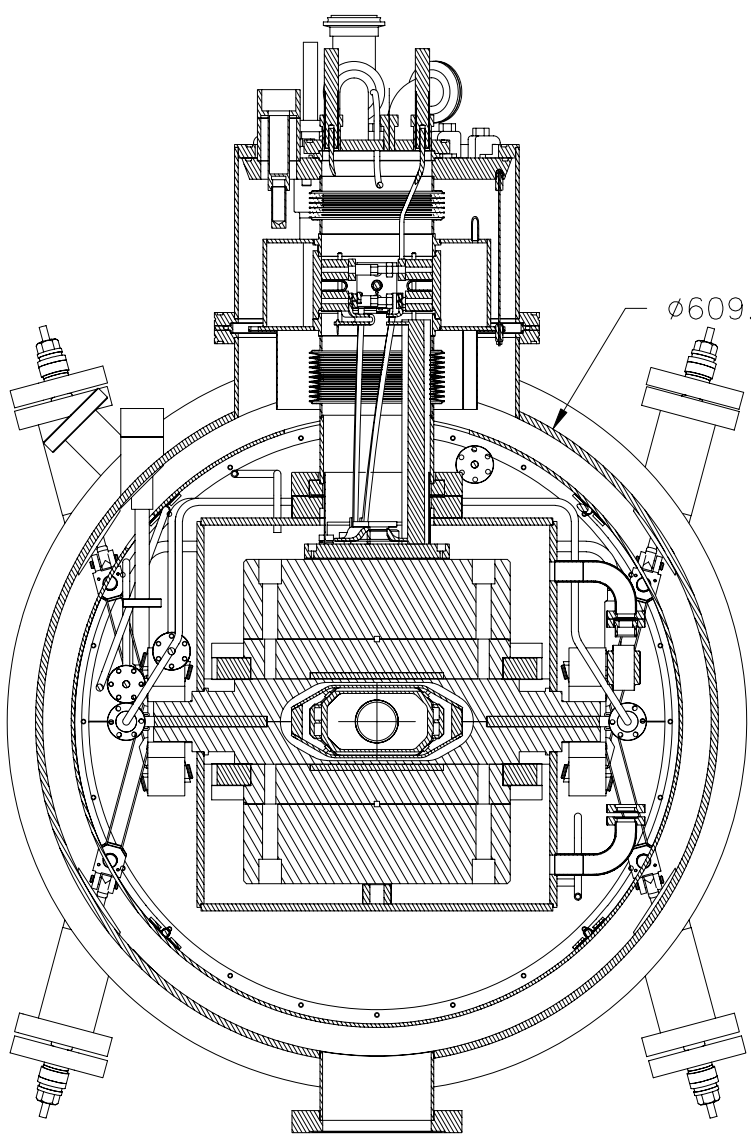

FOR MACHINING LUBRICANT USE ONLY
ALKALINE DETERGENT LUBRICANT CIMSTAR 40
OR EQUIVALENT APPROVED BY CORNELL LEPP.

ITEM	DWG. NO.	DESCRIPTION	QUANTITY			REMARKS	REV.
			G1	G2	G3		
PRINT DISTR.		PLOT DATE 06/02/03 CAD FILE NAME Z:\draft\archive\6000\6070\6070-078 CESRc 8-40 Wiggler Cryostat Asm\asm_6070-078_2D_sh0102.dwg					
CR-1		UNLESS OTHERWISE SPECIFIED DIMENSIONS ARE IN INCHES TOLERANCES ON: .00 ±.010 .000 ±.005 FRACTIONS ±1/64 ANGLES ±0.5° ALL SURFACES	 CORNELL UNIVERSITY LEPP LABORATORY FOR ELEMENTARY-PARTICLE PHYSICS F.R. NEWMAN LAB - ITHACA, NY 14853				
						CESR-c 8-40 Wiggler Cryostat Assembly -Sheet 02	
CHECKED BY APPROVED BY	KWS KWS	DRAWN BY DRAWN FOR	JGL KWS	DATE	SCALE	D 6070-078	REV. A
				02/11/03		SH. NO. 2 CONT. ON 3	

REVISIONS				
SYM.	ZONE	DESCRIPTION	DATE	APP.

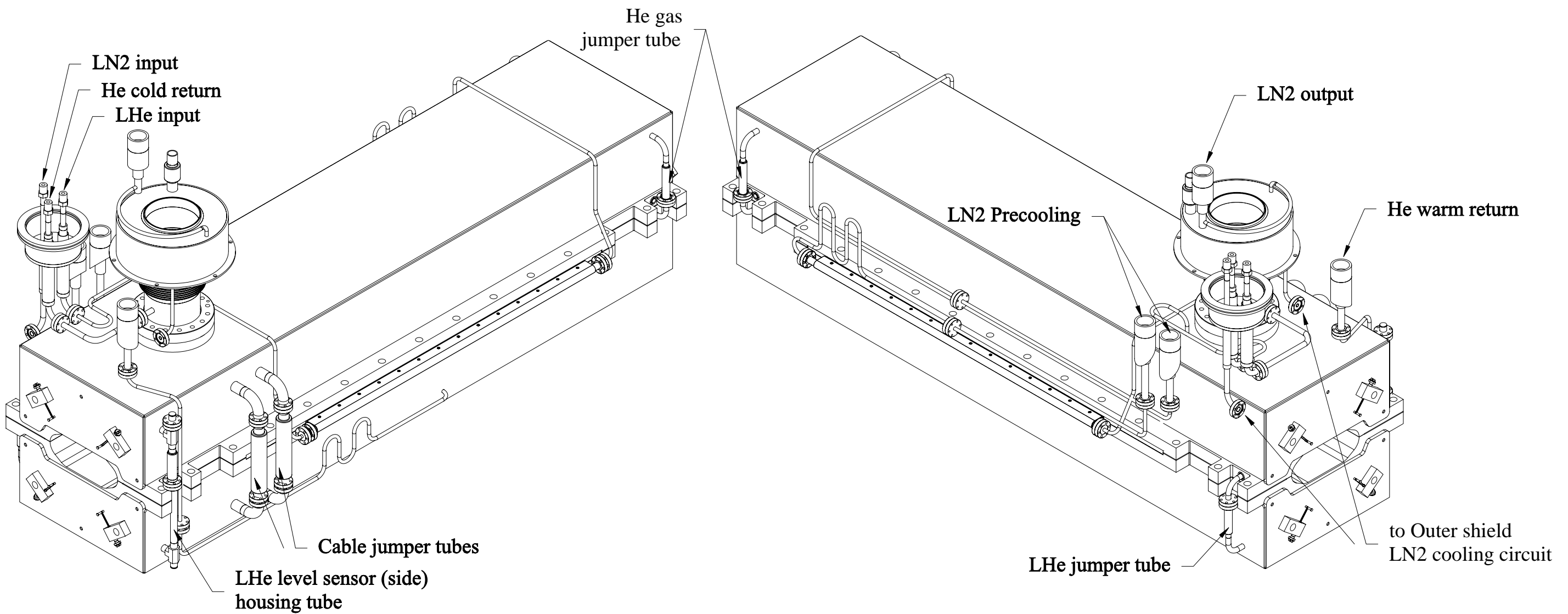

FOR MACHINING LUBRICANT USE ONLY
 ALKALINE DETERGENT LUBRICANT CIMSTAR 40
 OR EQUIVALENT APPROVED BY CORNELL LEPP.

ITEM	DWG. NO.	DESCRIPTION	G1	G2	G3	REMARKS	REV.
			QUANTITY				
PRINT DISTR.	PLOT DATE 06/02/03 CAD FILE NAME Z:\draft\archive\6000\6070\6070-078 CESRc 8-40 Wiggler Cryostat Asm\assm_6070-078-2d_sh03.dwg						
CR-1	UNLESS OTHERWISE SPECIFIED DIMENSIONS ARE IN INCHES TOLERANCES ON: DIM ±.010 HOLE ±.005 FRACTIONS ±1/64 ANGLES ±0.5° ALL SURFACES \sqrt{R}	 CORNELL UNIVERSITY LEPP <small>LABORATORY FOR ELEMENTARY-PARTICLE PHYSICS F.R. NEWMAN LAB - ITHACA, NY 14853</small>					
		CESR-c 8-40 Wiggler Cryostat Assembly - Cryogenic Plumbing					
CHECKED BY APPROVED BY	KWS KWS	DRAWN BY Yun HE	DRAWN FOR Yun HE	DATE 05/21/03	SCALE 1:4	D 6070-078 <small>SH. NO. 3 CONT. ON FIN.</small>	REV.