

FAST KICKERS STATUS

Fabio Marcellini

*On behalf of LNF fast kickers study group**

** D. Alesini, F. Marcellini P. Raimondi, S. Guiducci.*

PRESENTATION OUTLINE

1. Design and tests of a strip line kicker for beam injection in DAFNE storage rings.
2. Study of a strip line kicker for ILC damping ring.

DESIGN OF THE NEW DAFNE INJECTION KICKER

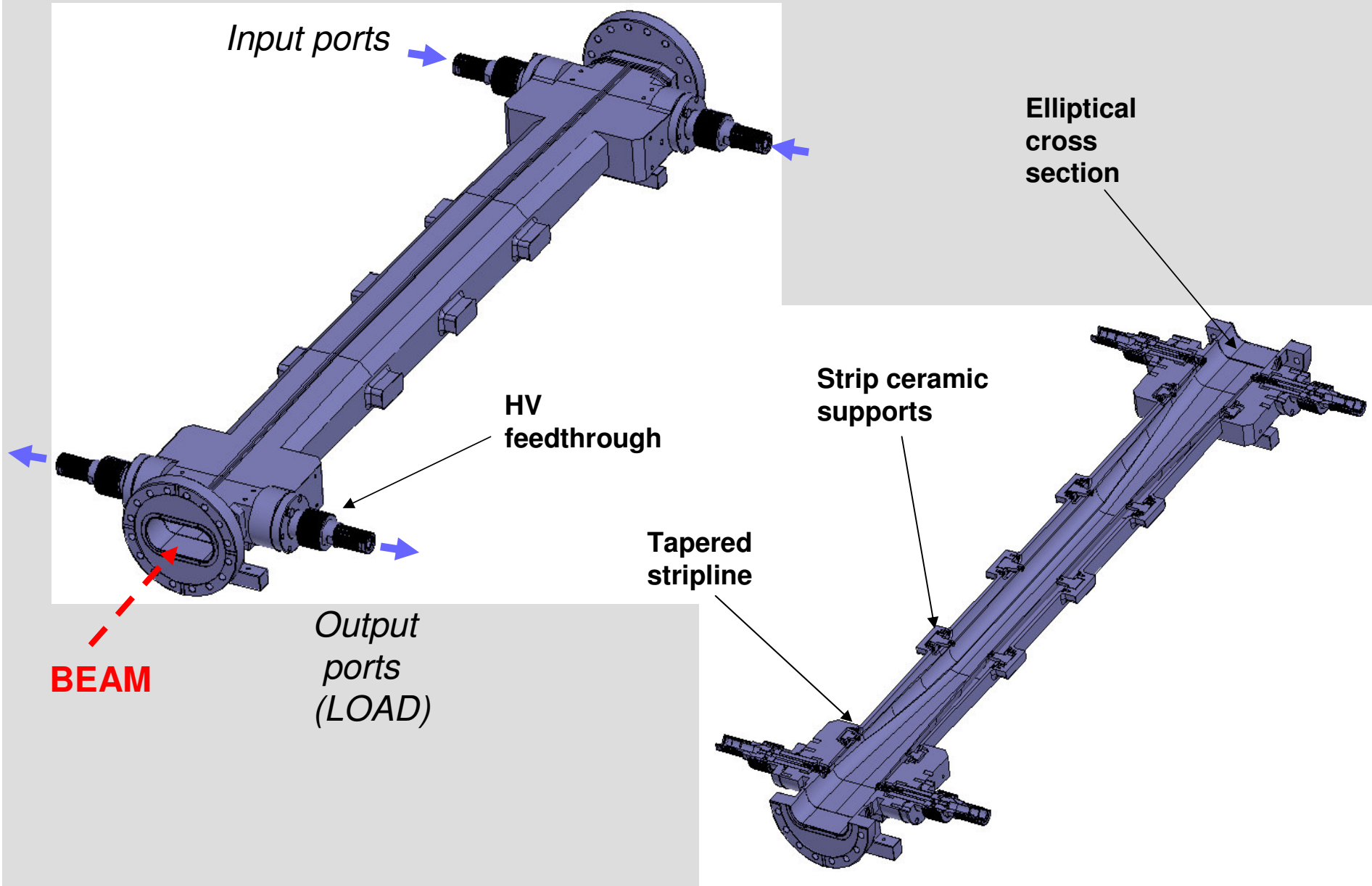

The elliptical cross section:

minimizes the discontinuity of the beam pipe cross section between the injection region and the adjacent dipole regions

increases the deflection efficiency.

The tapered stripline:

Improves the **uniformity** of transverse deflection as a function of the transverse position

Reduces the contribution of the kicker to the machine **impedance**

improves the **reflection coefficient** at high frequency (short pulses) because of smoother transition between feedthrough coax line and stripline.

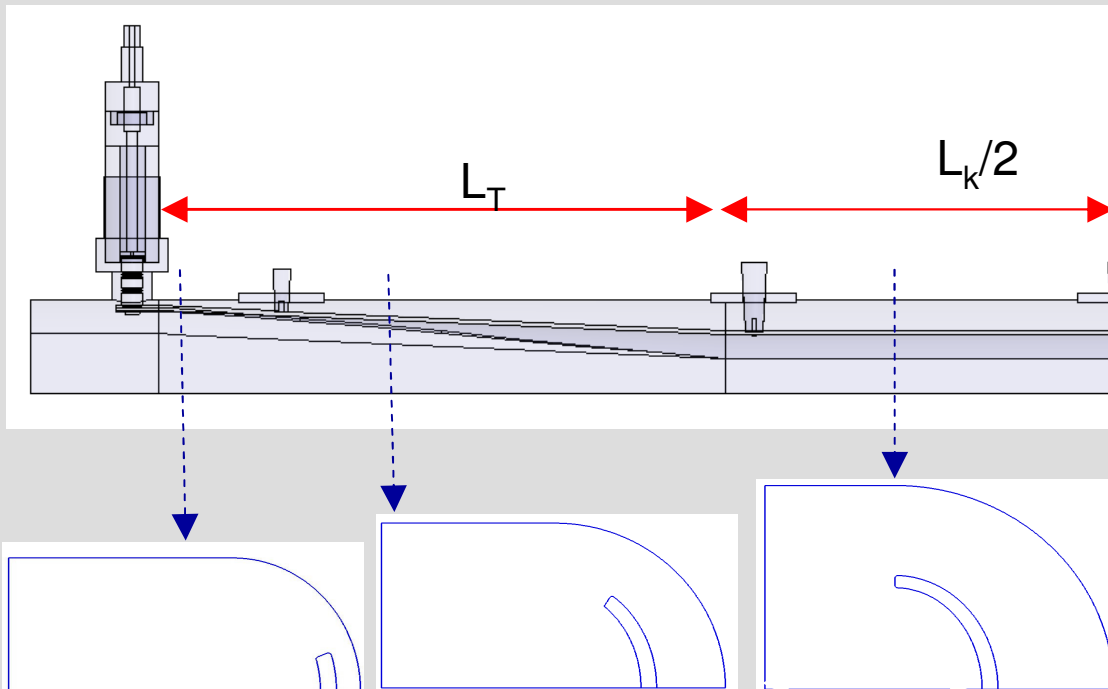

Field flatness by integration

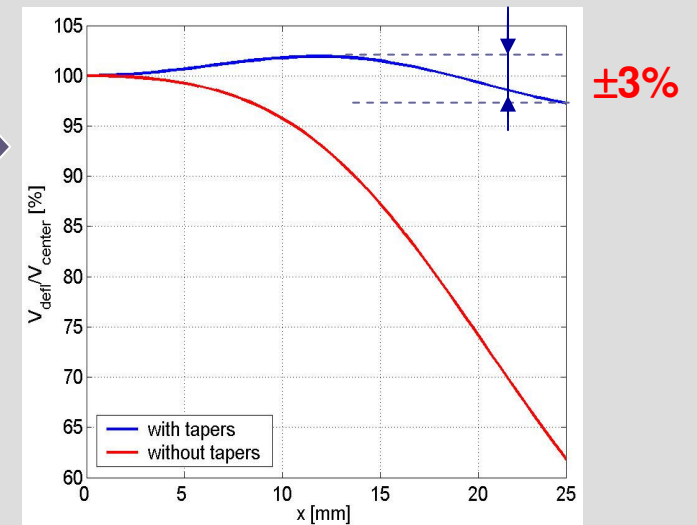

injection kicker parameters

PARAMETERS	
Beam Energy E [MeV]	510
Time spacing between bunches [ns]	2.7
Deflection [mrad]	5
Total deflecting voltage VT [MV]	2.5
Total kicker length L [cm]	~90
Voltage per strip [kV]	45
Input pulse length [ns]	~ 5
Pulse length "seen" by bunches [ns]	~10
Max rep rate [Hz]	10

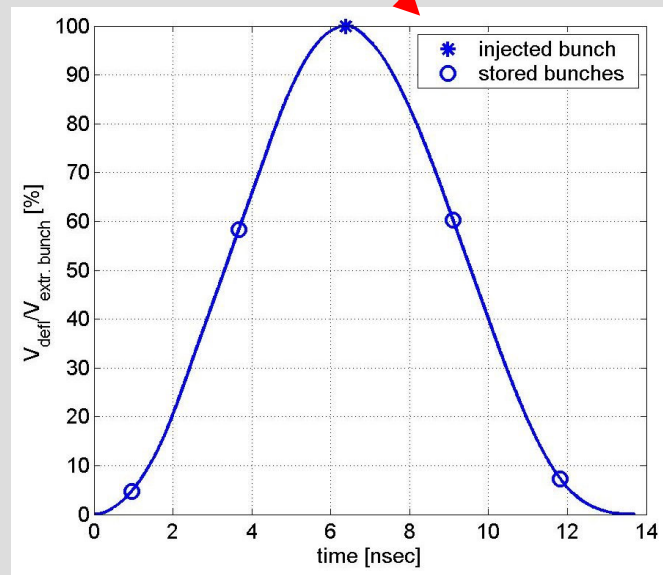
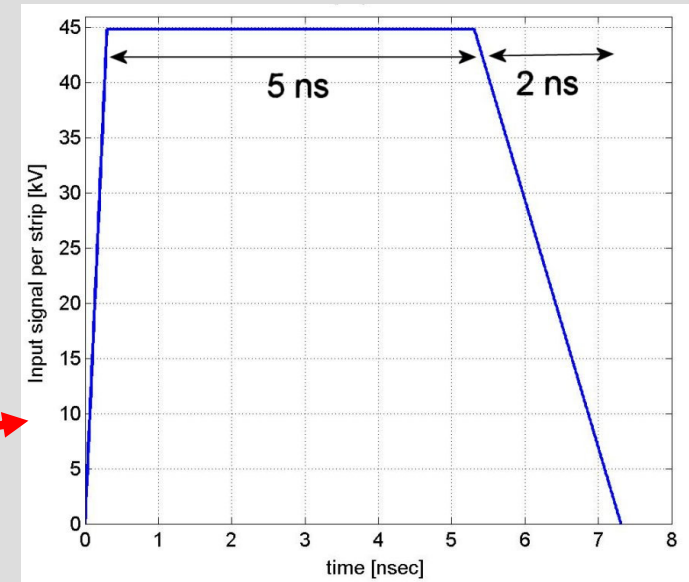

High Voltage tests

When HV is applied the **possibility of discharges** is higher in the **end-section** of the kicker electrodes, where the electrode itself is closer to the vacuum tube.

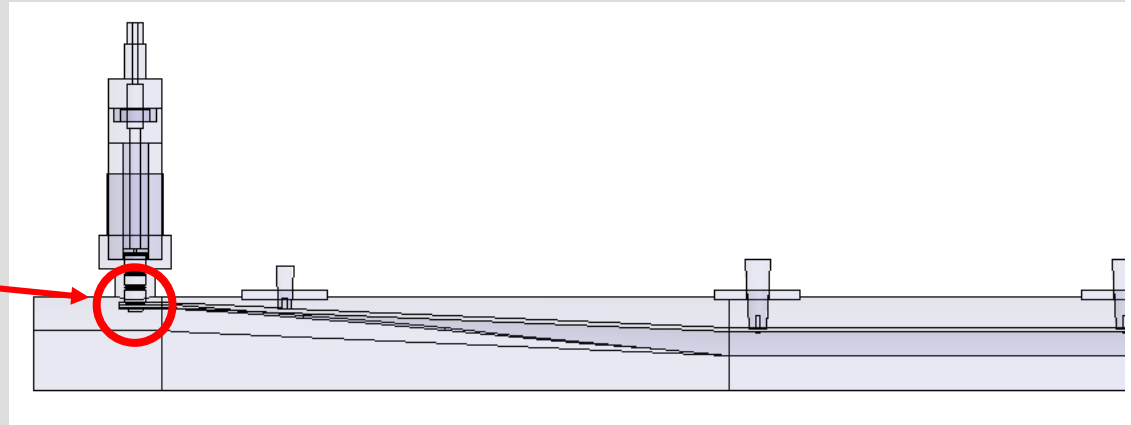

The device in the pictures has a **stripline** with the same dimension and the same distance from the chamber of the kicker stripline in the end section. It was built for HV tests on the stripline and on the developed **coax feedthroughs**.

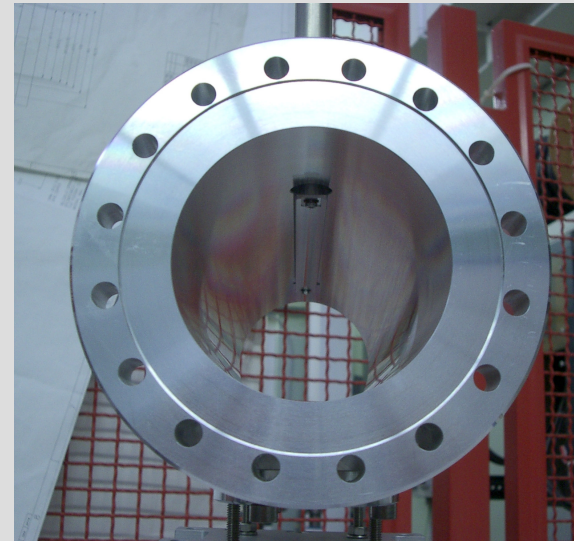
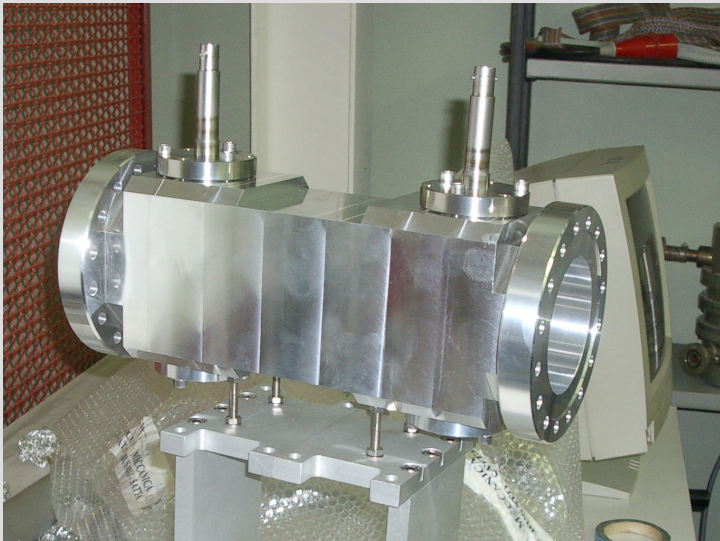

HV 50 Ohm (wide band) **commercial feedthroughs do not exist** and an R&D activity has been necessary. The wide band of the feedthroughs is important to **keep low the beam impedance** of the kicker even well beyond the frequency spectrum of the input pulse.

R&D on HV feedthrough

A *commercial feedthrough* (not 50 Ohm) has been initially tested *without success*.



An *HV feedthrough at 50 Ohm* has *been designed, realized and tested at LNF* with complete *success* up to 50 kV with the FID pulser.

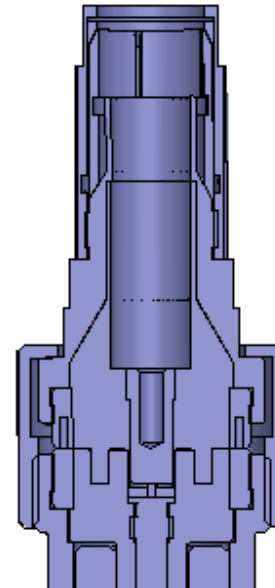

HV tests of the stripline and the feedthrough have been done with DC 30 kV power supply and with the prototypes of the HV pulsers that FID GmbH was producing in the meanwhile.

HV tests on the new kickers

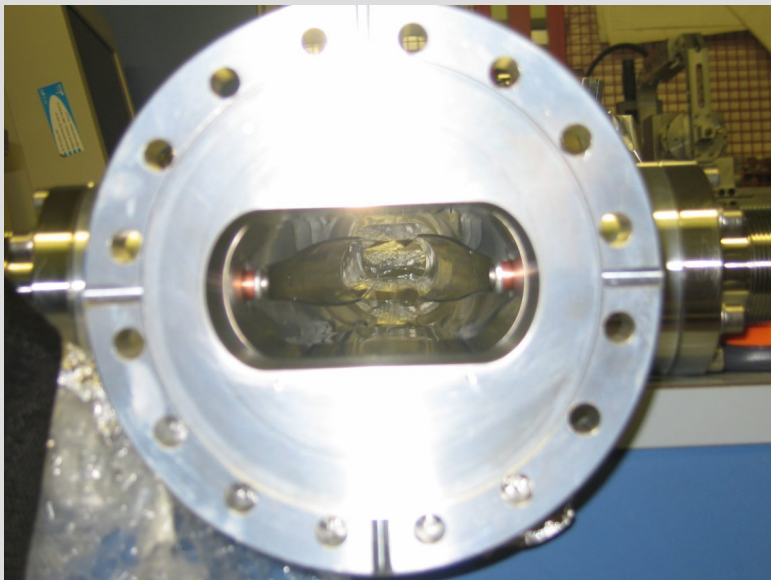
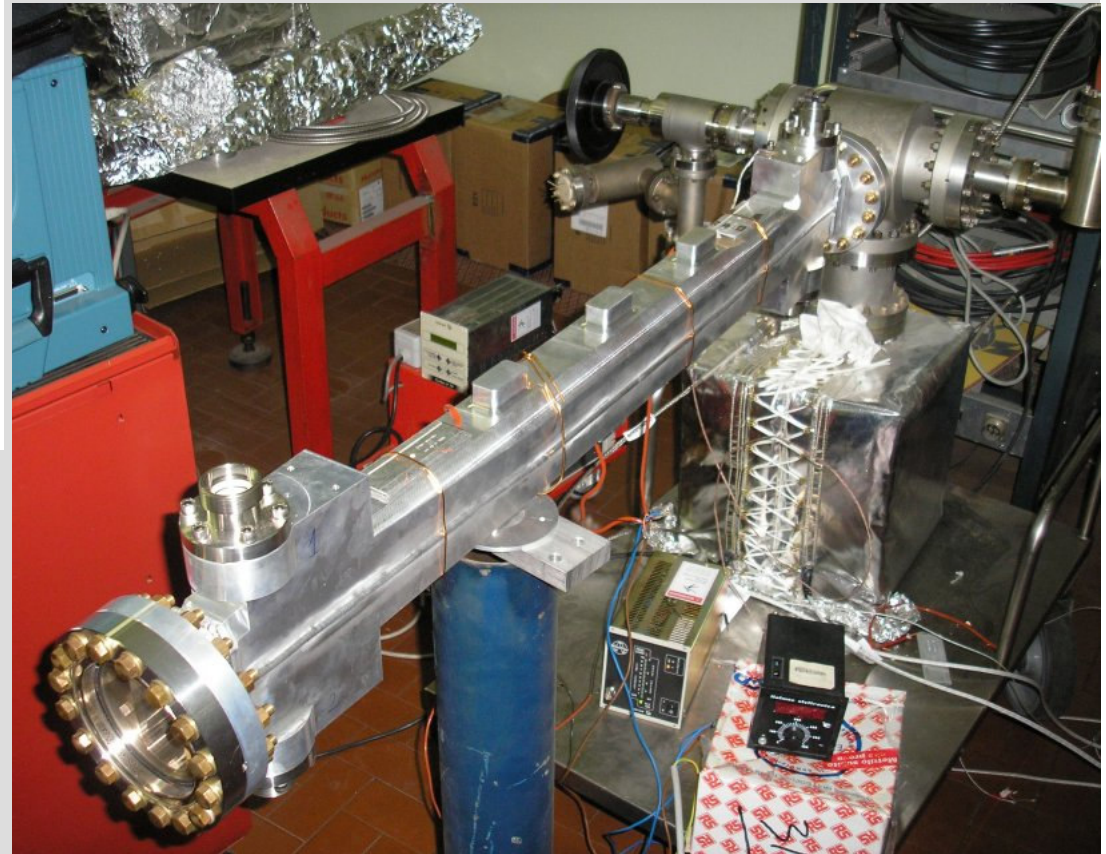
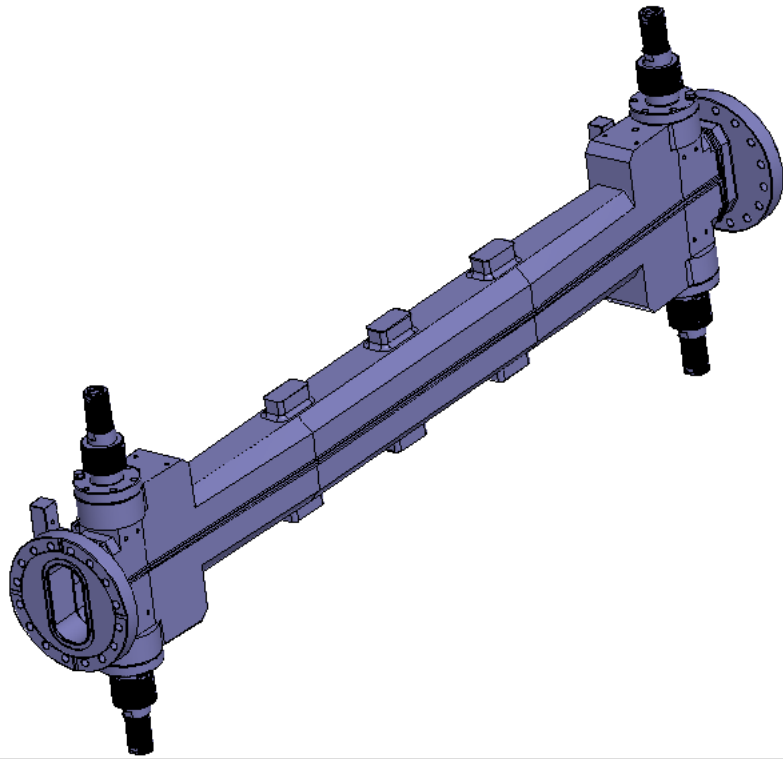

HV tests on the new kickers



Old pulser (LNF)

New pulser (FID)

45 kV

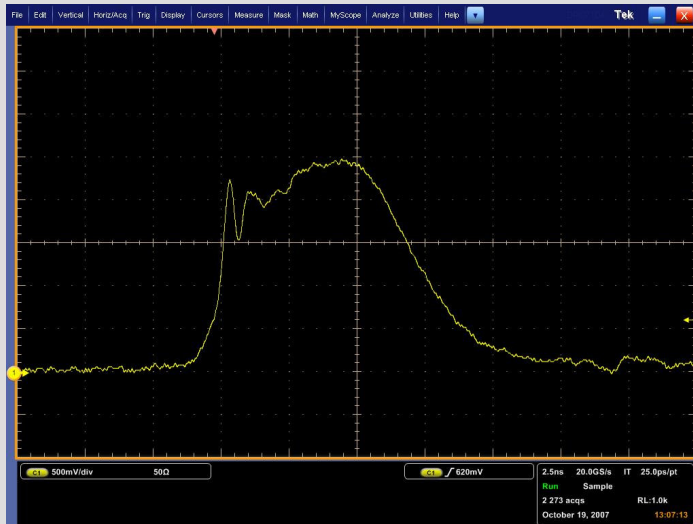

5 ns

25 kV

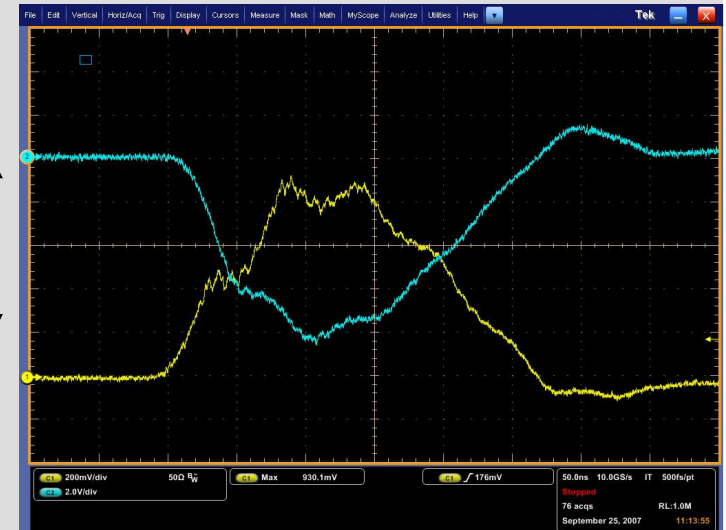

250 ns

HV tests on the new kickers

New pulser (FID)

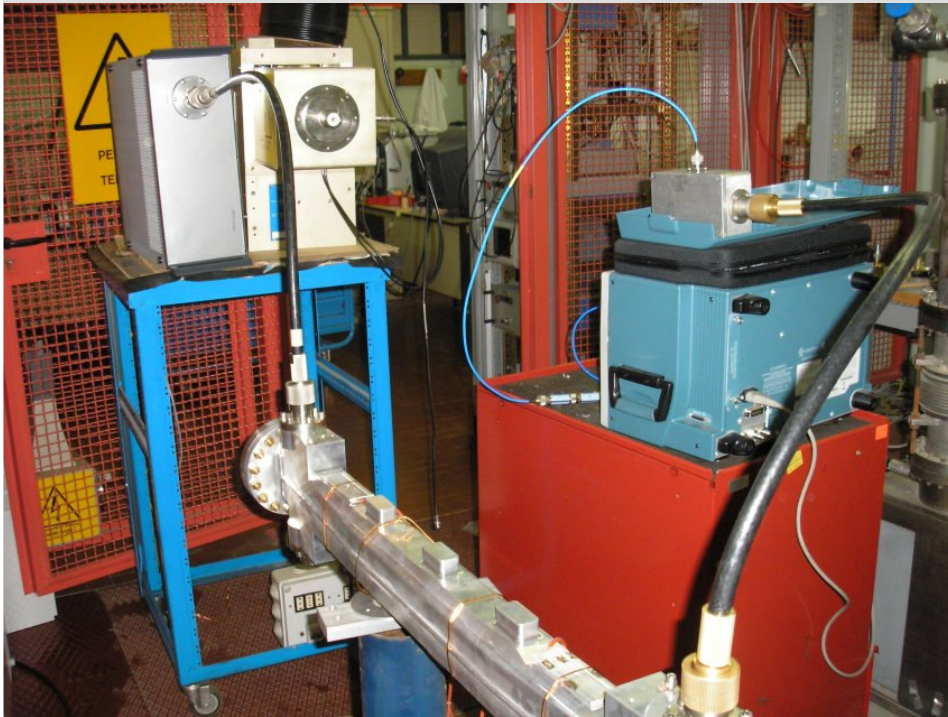

Old pulser (LNF)

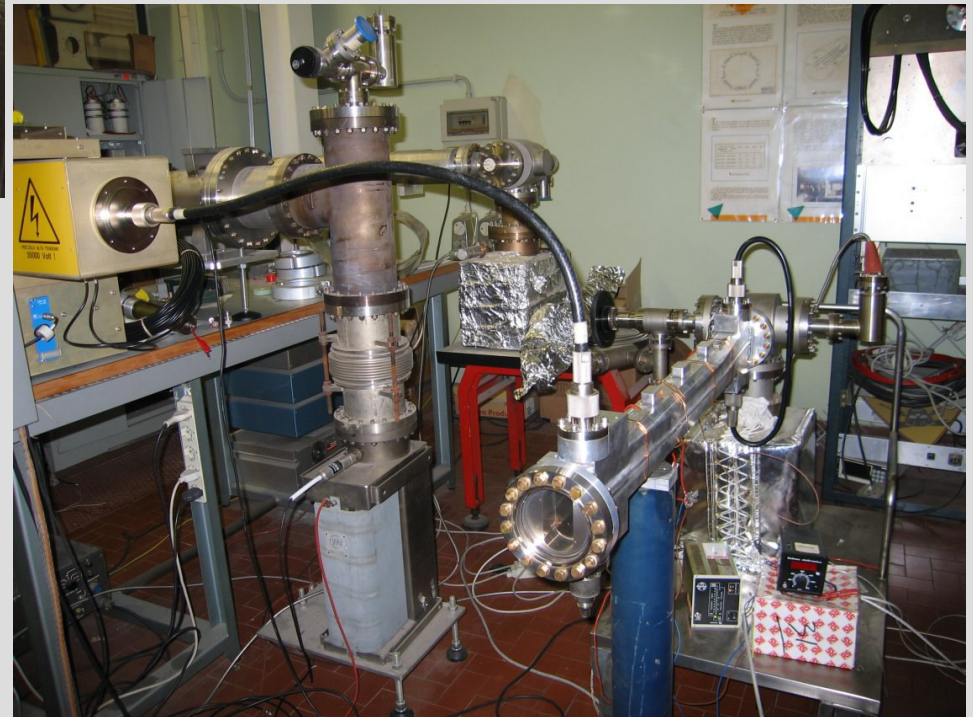

RF test on the new injection kickers

Connectors for RF test with NA

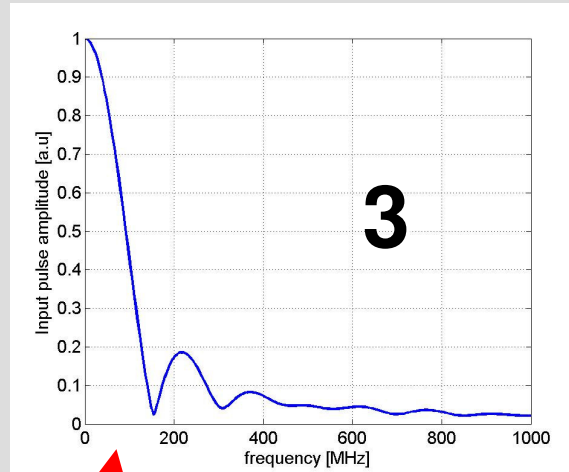

simulations

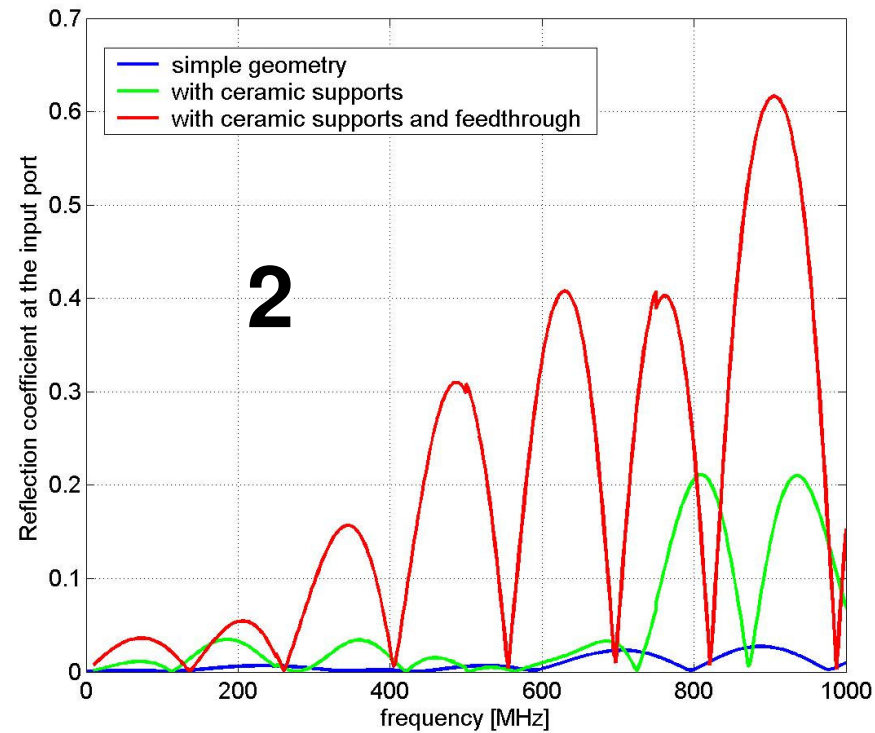

measurements

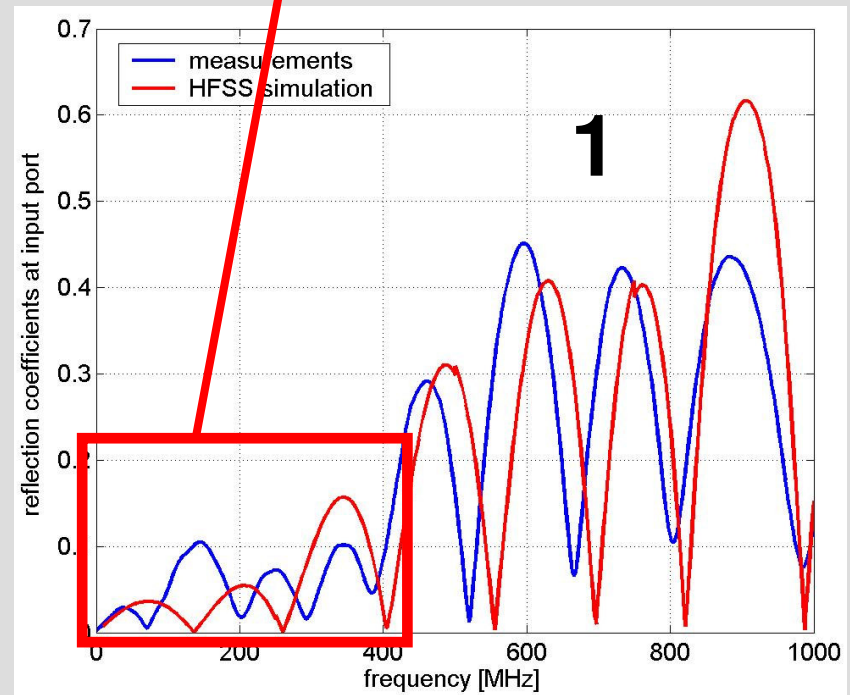

Longitudinal impedance measurements: wire method

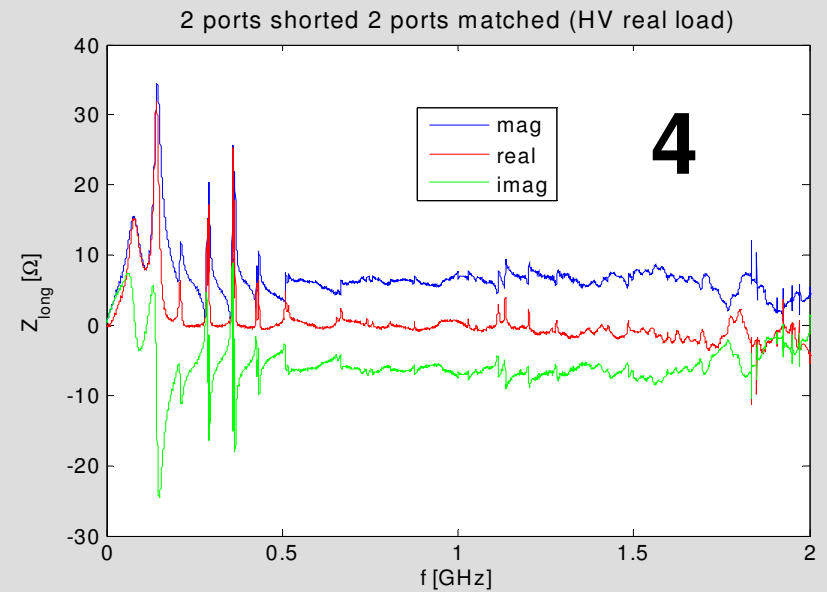
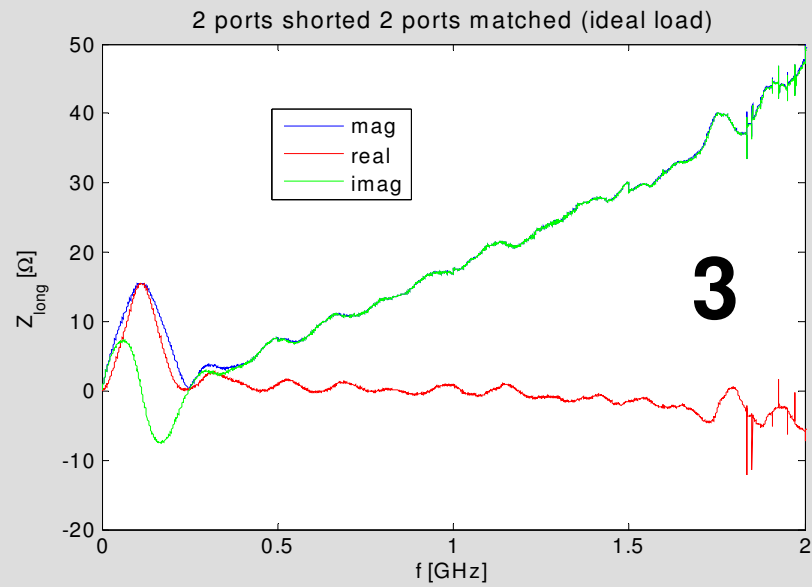
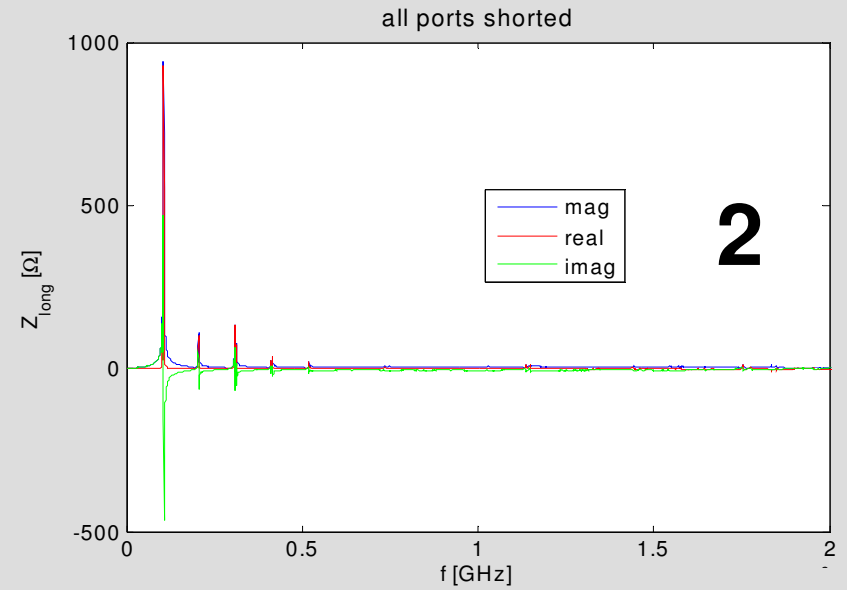
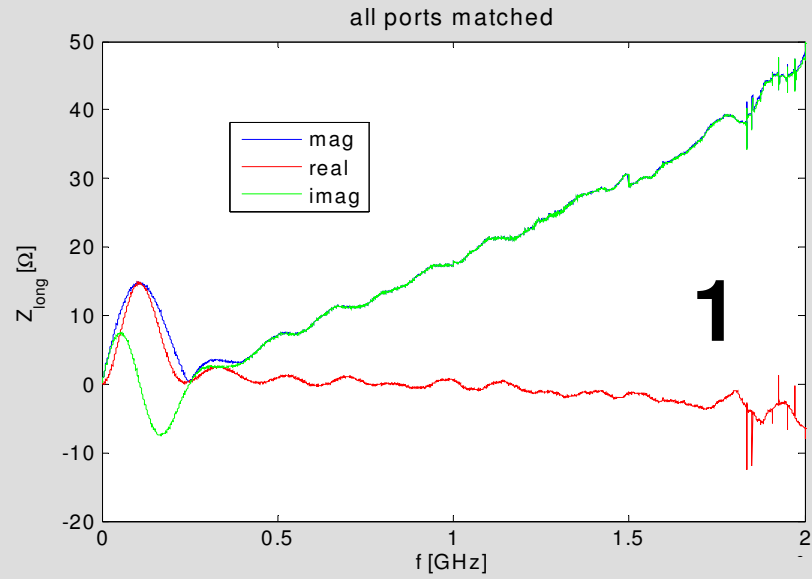

New kickers installed in the DAΦNE rings (Nov. 07)

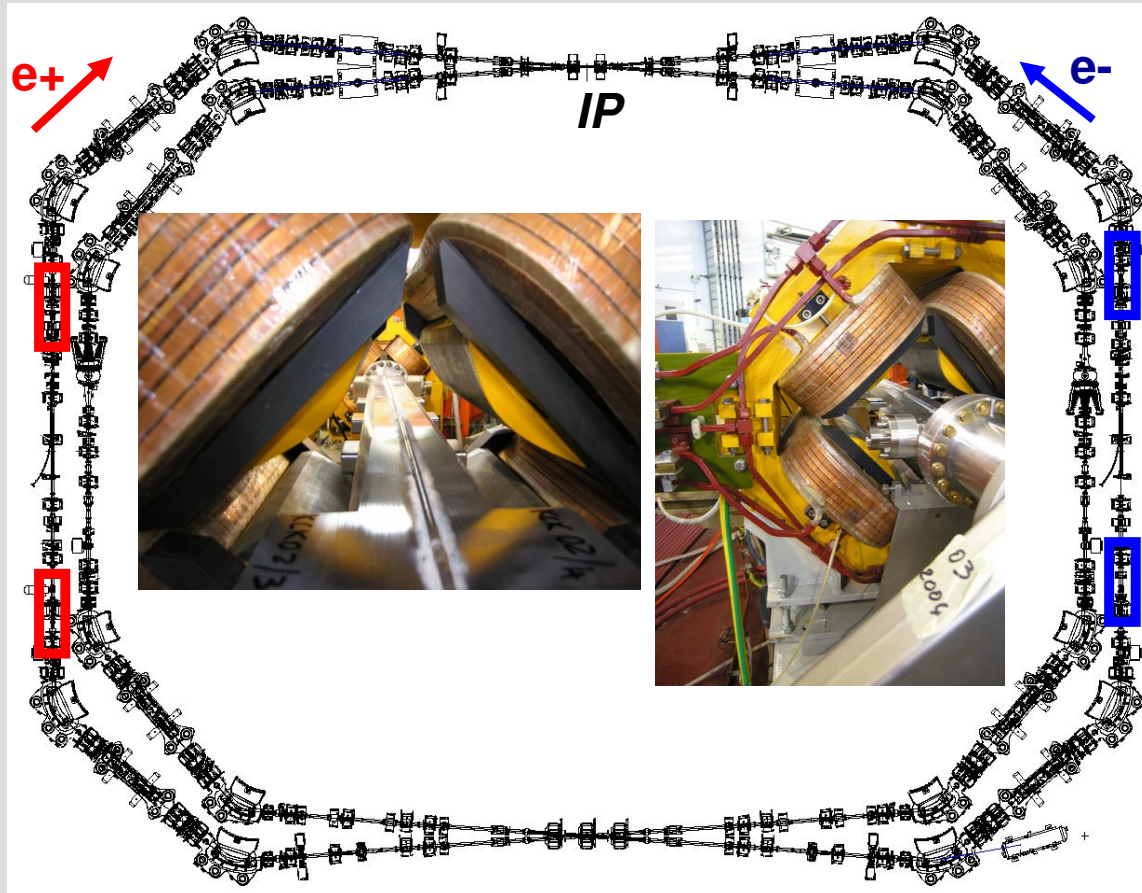

Final version of the **FID pulsers** has shown **poor reliability**. At present only 2 pulsers of 4 are good.

We are **now running with the old**, long pulse system in both the rings.

We are thinking to **use an hybrid system in e+ ring** connecting both the old pulser and the survived new one to each kicker.

With the aim to improve their reliability, **FID GmbH is working on the 2 failed pulsers**, replacing the weaker components with other of new design.

STUDIES ON THE ILC KICKER

STARTING POINT PARAMETERS

$$\beta_{x_KICK}=65 \text{ m}; \beta_{y_KICK}=20 \text{ m}$$

$$A_{x_max}=A_{y_max}=0.09 \text{ m}\cdot\text{rad (injected)}$$

Bunches distance = 3.08 ns

2 possible no tapered stripline geometries

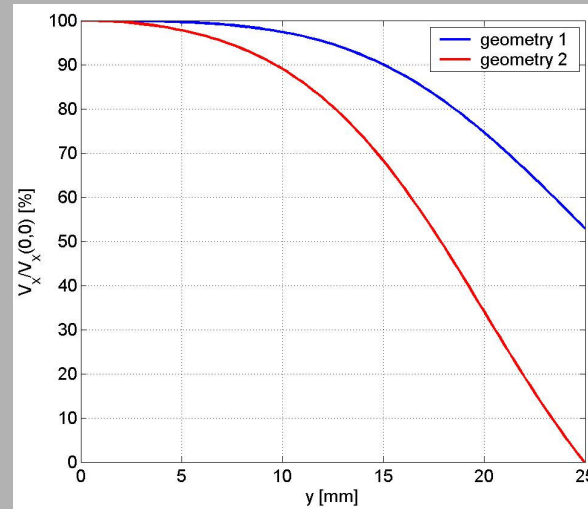
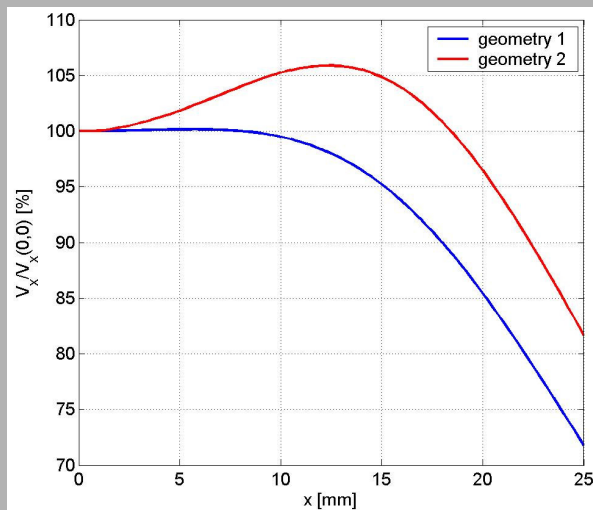
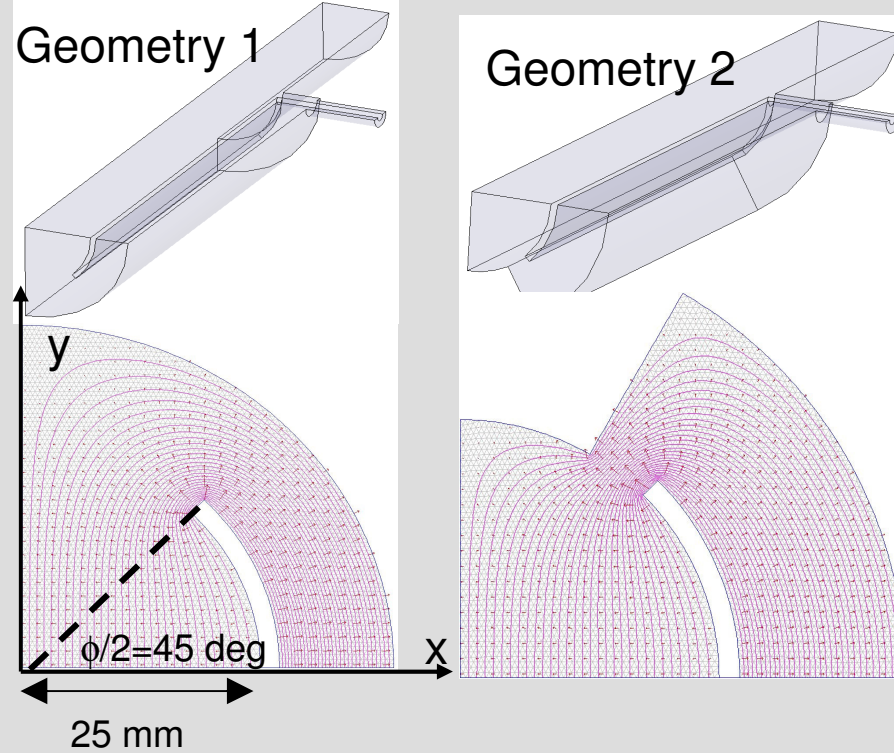

deflecting field
vs. horizontal
coordinate

uniformity of the deflecting field

Geometry 1

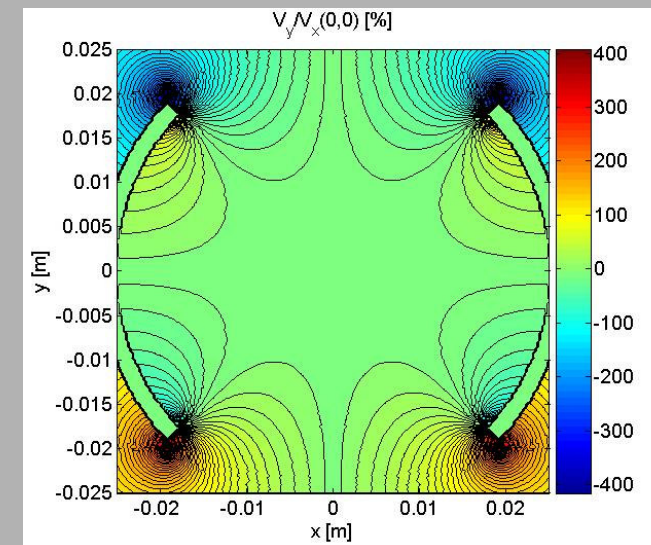
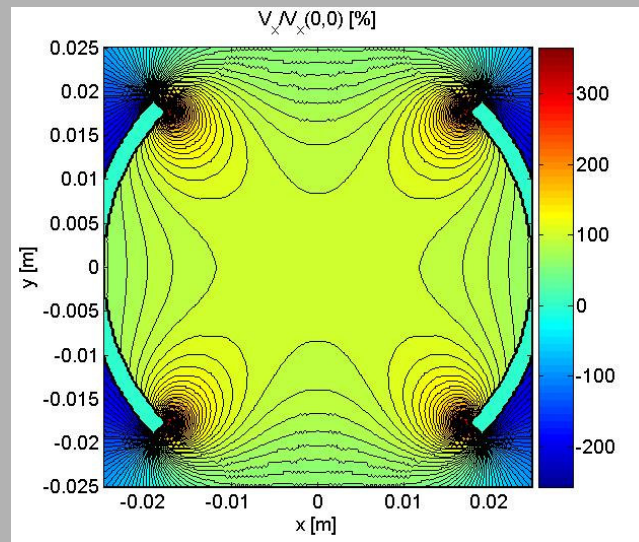

Geometry 2

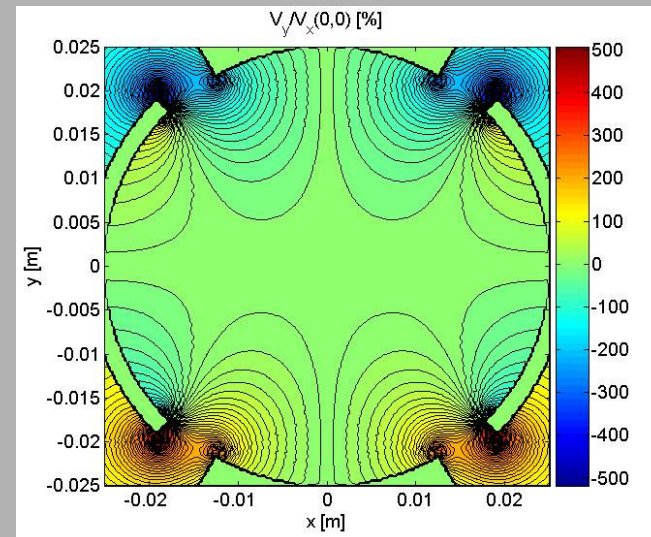
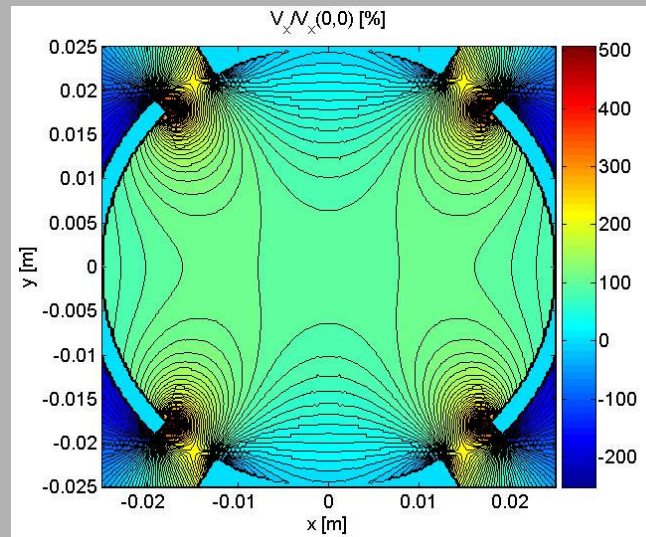

the non-uniformity of the deflecting field affects the distribution of the particle in the bunch.
This effect has been studied and results are reported for example in:
<https://wiki.lepp.cornell.edu/ilc/bin/view/Public/DampingRings/KEKWorkshopTalks>

TAPERED STRIPLINE DESIGN

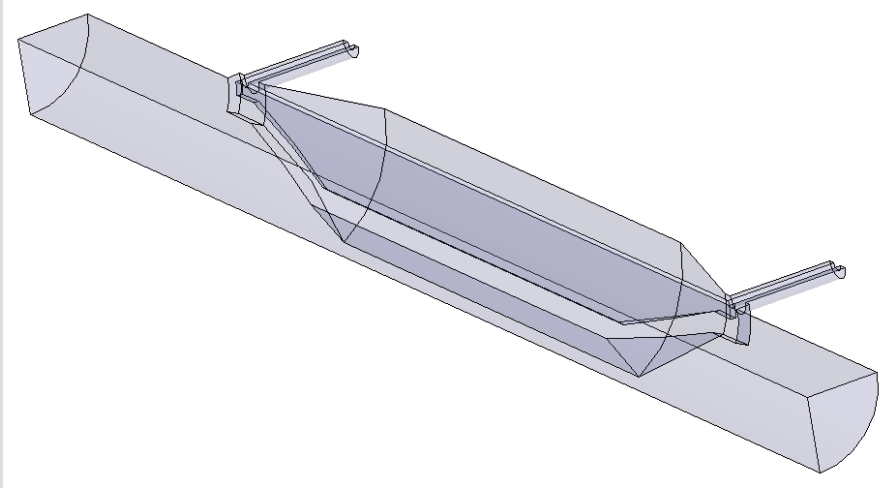

Stripline overall length: 300mm
tapered length: 50mm

coupling impedance

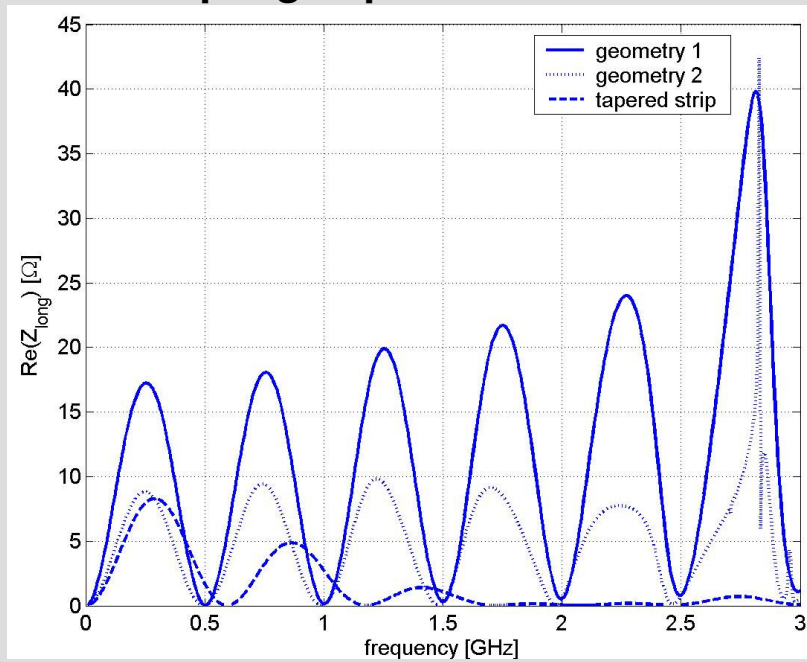

transfer impedance

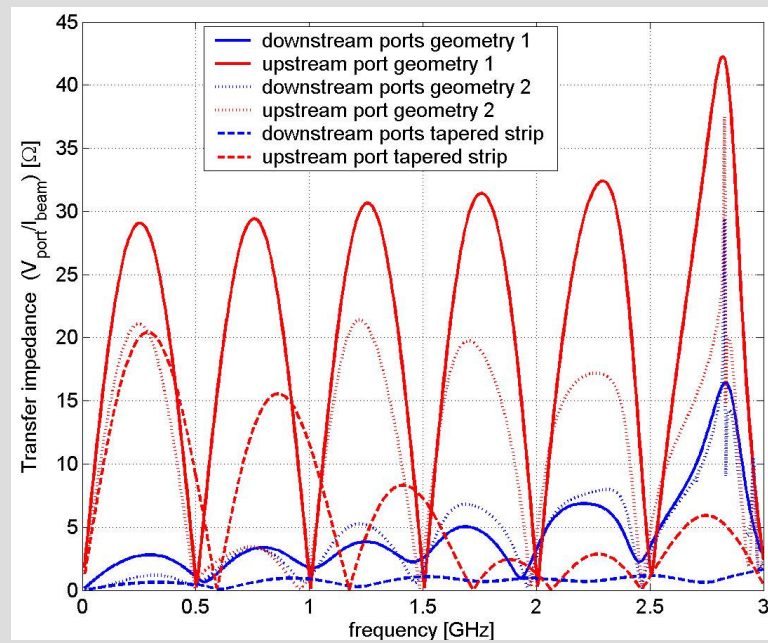

Future programs

In the DAFNE positron ring:

- Test a hybrid configuration where an old long pulse generator is connected to one kicker stripline and a new FID fast pulse generator to the other stripline.
- When the improved version of the FID pulsers is ready and their reliability tested, replacing of the old pulse generators.

Installation of “*dump*” *kickers* (2 more kickers already built) in both the DAFNE rings.

This will allow to *test* different pulser version and different kind of pulsers with the beam.

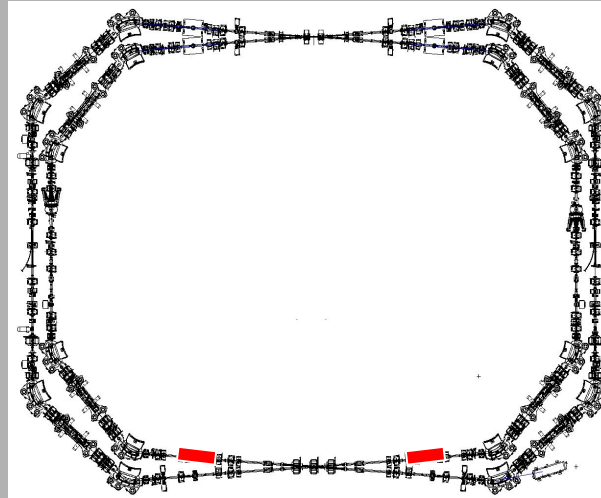

Build a prototype kicker for ATF.

- Design is in progress (almost completed).
- We have already the CeramTec feedthroughs pointed out by Naito
- Realization is foreseen within the end of 2008.