

# Strip-line Kicker R&D at KEK-ATF

T.Naito(KEK)

*ILC damping ring teleconference  
17Sep2008*

## Beam kick profile by the beam oscillation amplitude

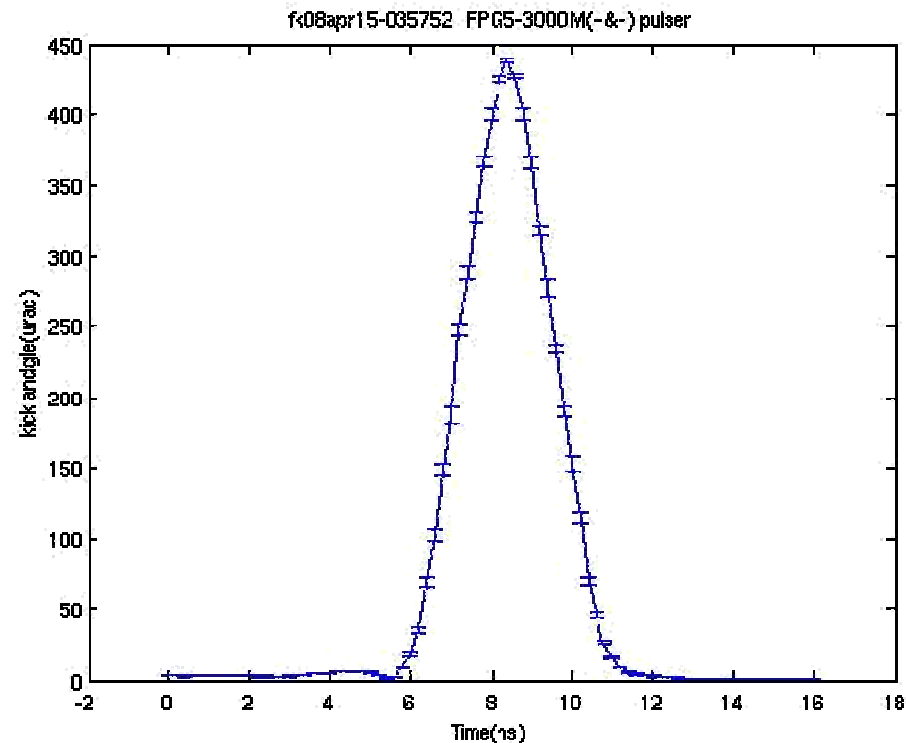

Beam kick test in the DR had been carried out by using 30cm strip-line electrode and a pair of 5kV FID pulser. The picture shows the timing scan of the kick pulse to the beam, when the Positive and Negative pulses(5kV) are applied at the same timing. The peak kick angle is 0.44mrad and the rise time of the kick field is 3ns, which agreed with the estimation from the kick voltage and the strip-line dimensions.

# Experiment at ATF2

ATF2 - 40nm beam production, measurement

Extraction kicker

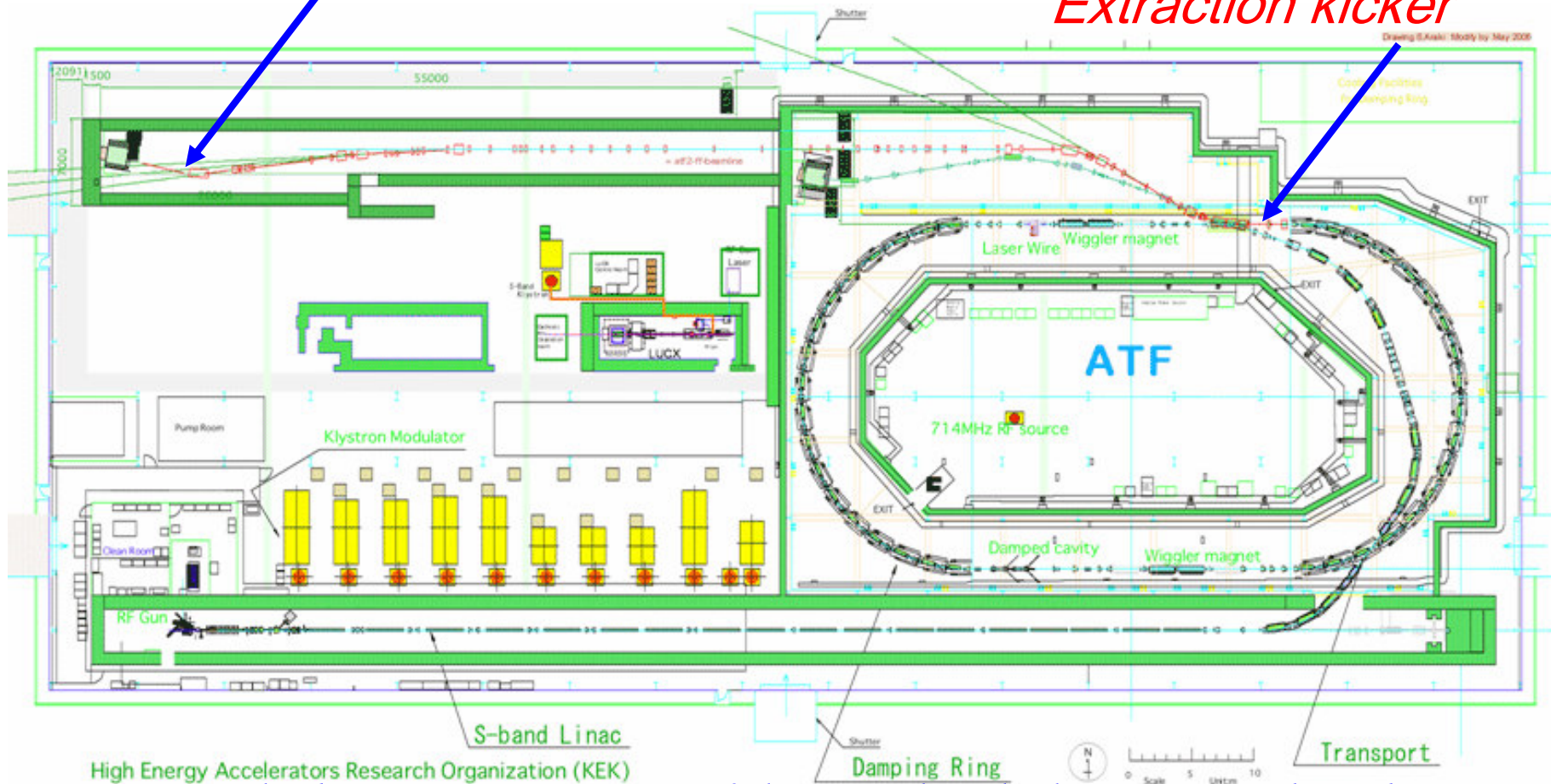

High Energy Accelerators Research Organization (KEK)

The beam extraction test of the strip-line kicker is carried out by replacing the pulse magnet of the extraction kicker. The kick angle of strip-line kicker is not enough compared to the kick angle of the existing pulse magnet.

# Present layout

20051221 T.Naito

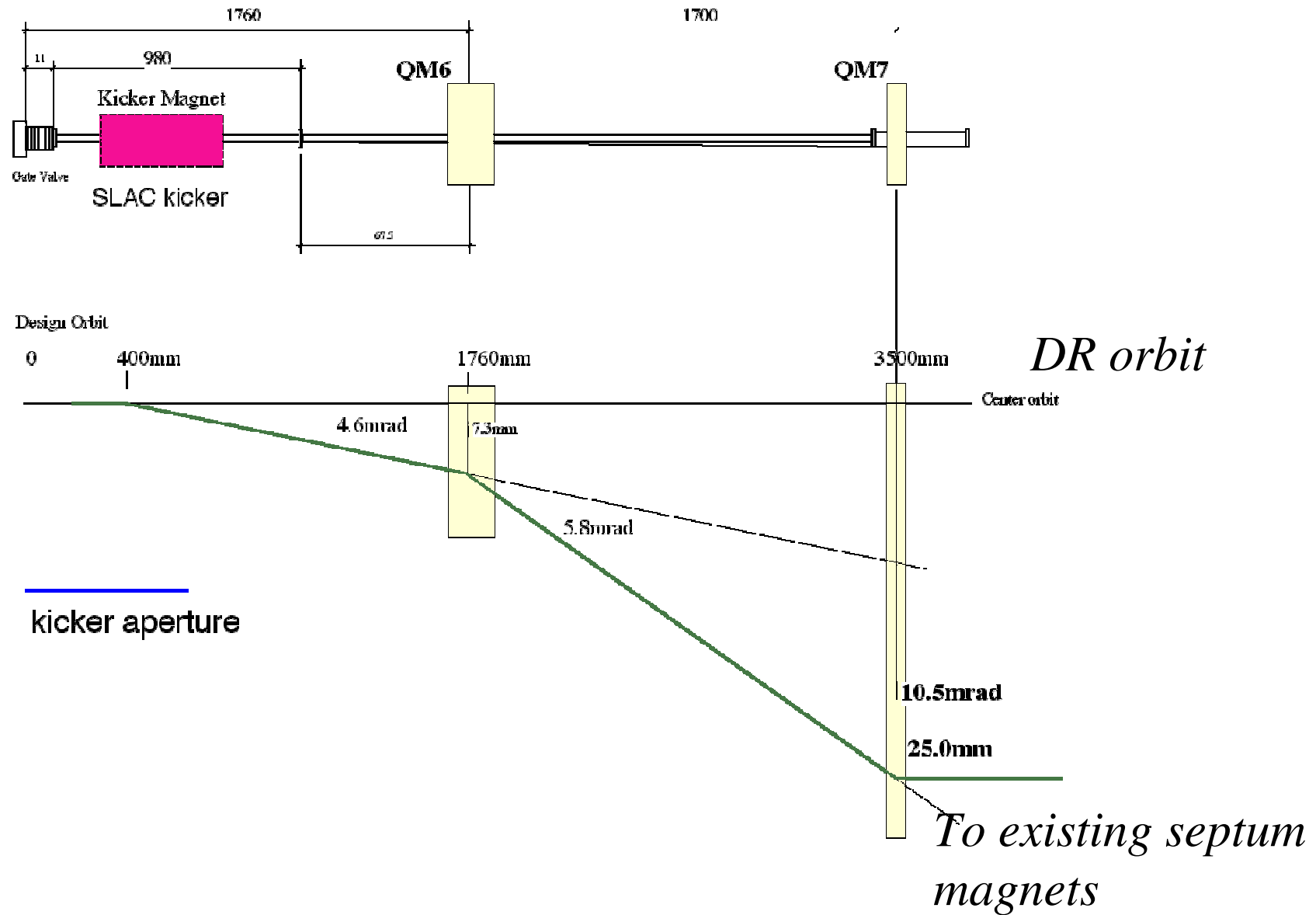

2008/9/19

# Beam extraction orbit by using Strip-line Kicker

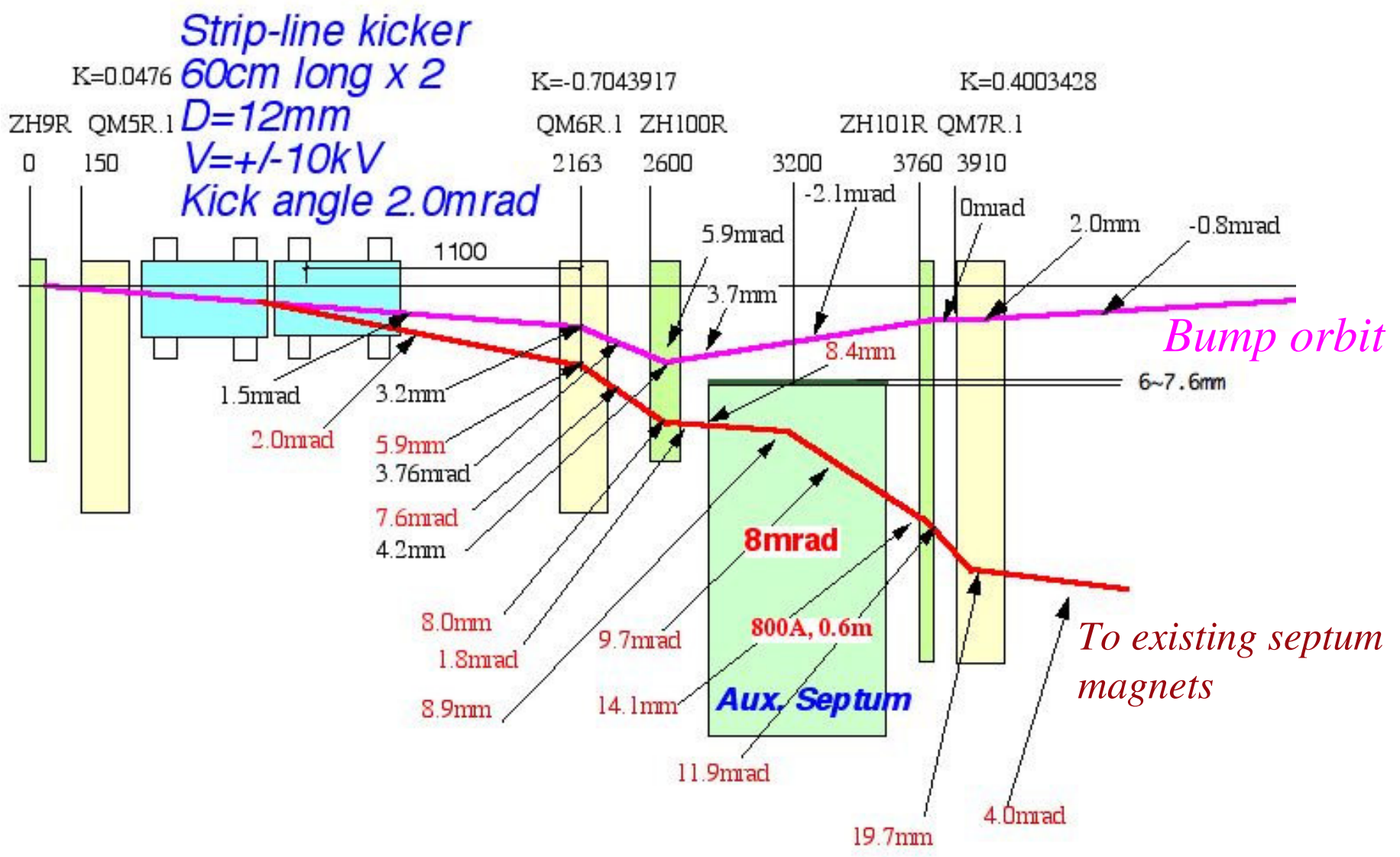

# Pulse source(FID FPG 10-6000KN )

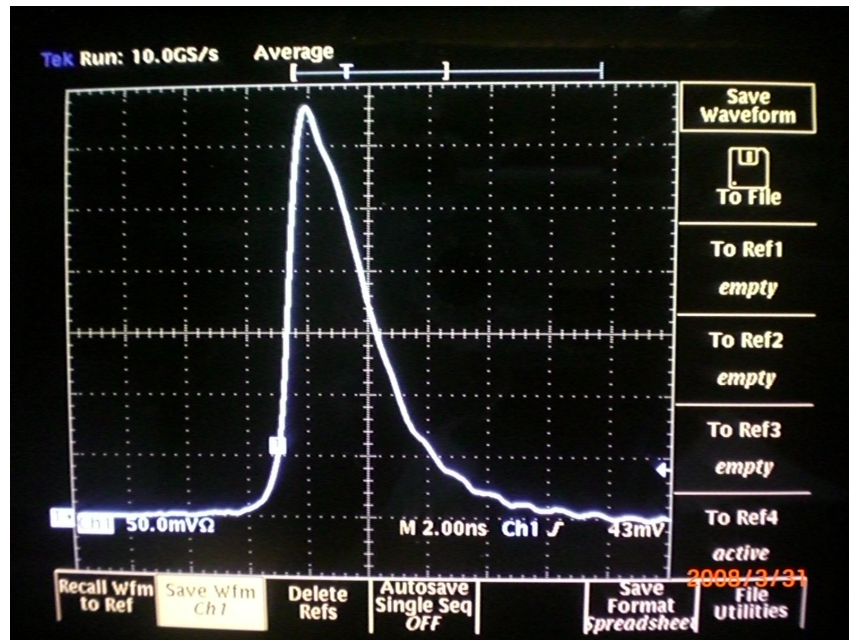

## Specification

Maximum output voltage + 10 kV

- 10 kV

Rise time @ 10-90% level - < 1 ns

Rise time @ 5-95% level - < 1,2 ns

Pulse duration @ 90% - 0,2-0,3 ns

Pulse duration @ 50% - 1,5-2 ns

Output pulse amplitude stability - 0,5-0,7%

Maximum PRF in burst - 6,5 MHz

Number of pulses in burst - up to 110

PRF of bursts - up to 5 Hz

# Proto type strip-line kicker(30cm long)

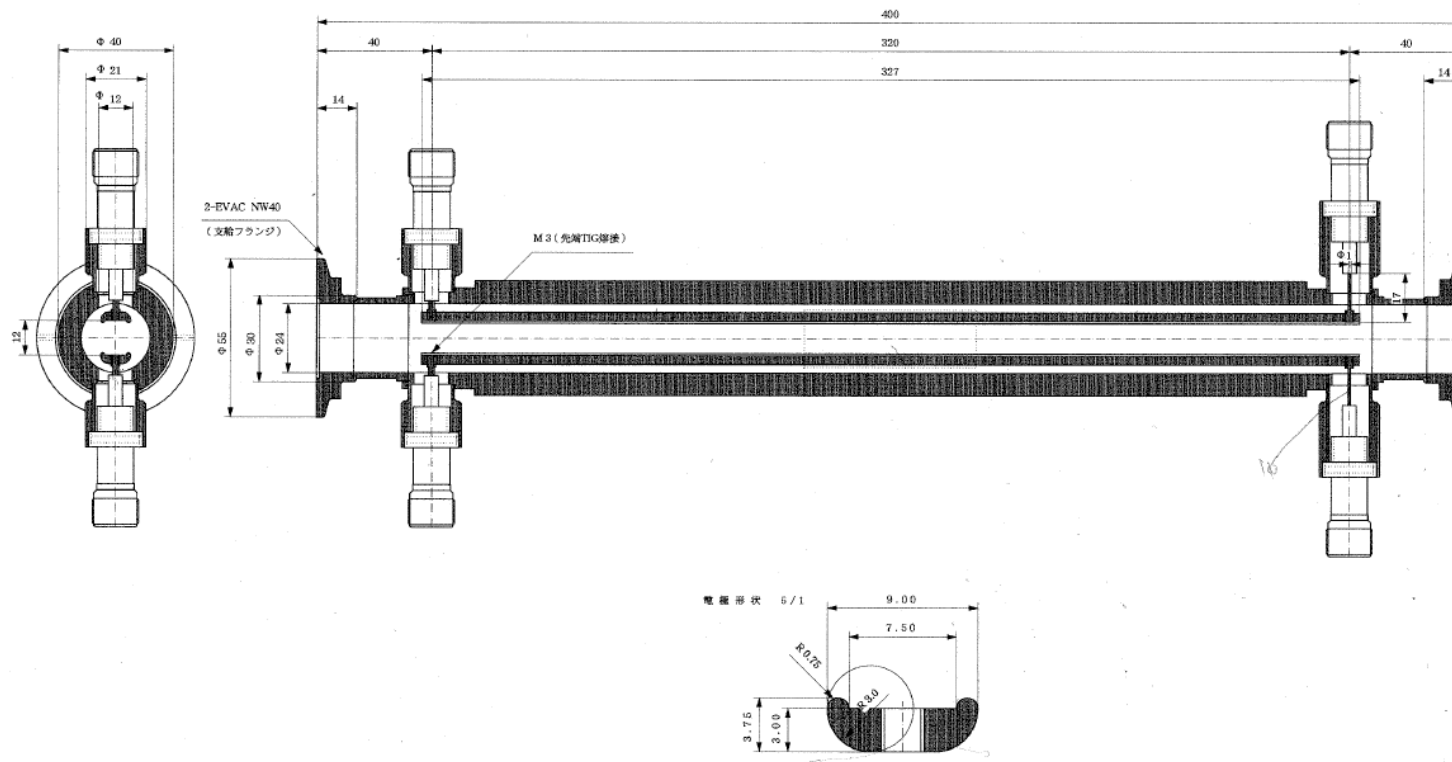

KEK fabricated a proto type 30cm long strip-line kicker, which has 12mm electrode gap. The input/output connectors are HN-type commercial available feed-through.

This version is fabricated for the kick field measurement. The length is decided by the space of the south straight section of the ATF-DR. It need to check the beam kick performance without discharge when applied +/-10kV pulse.

## Photo of the fabricated strip-line kicker

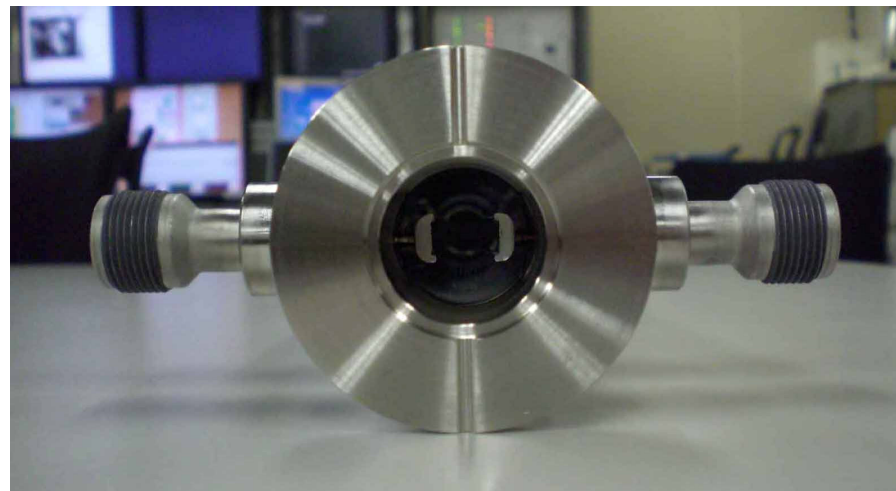

2008/9/19



# Aperture

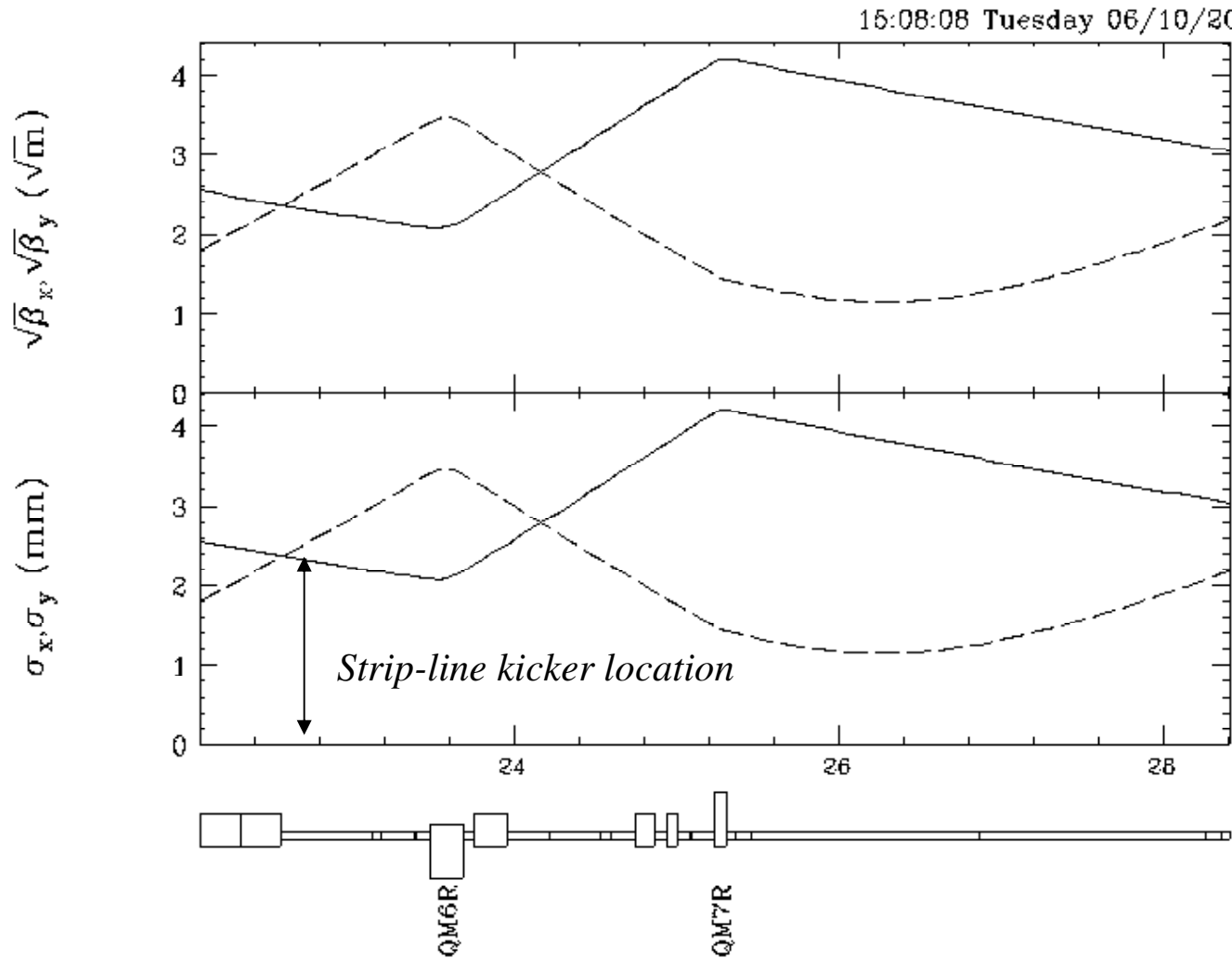

$$Ex(inj.)=1e-6,$$
$$Px(inj.)=1e-2$$

Horizontal aperture is limited by the strip-line electrode.  $3\sigma$  of the injection beam can get through a 12mm gap of the strip-line kicker section.

# 10kV pulse apply to the strip-line

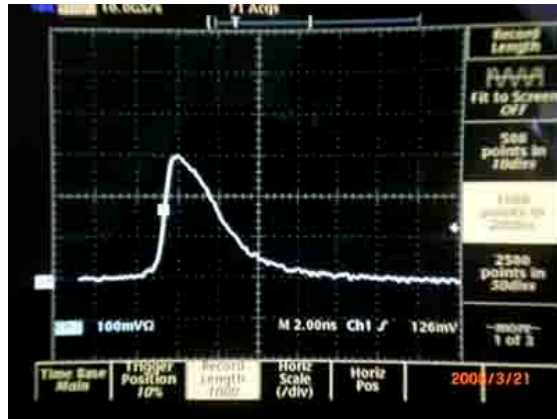

Pulser output(pos) 9.7kV peak

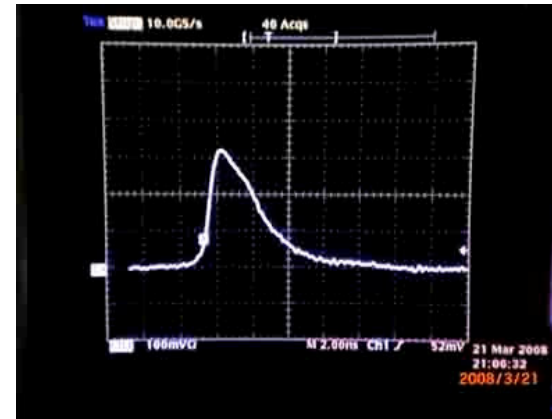

Strip-line output(pos)

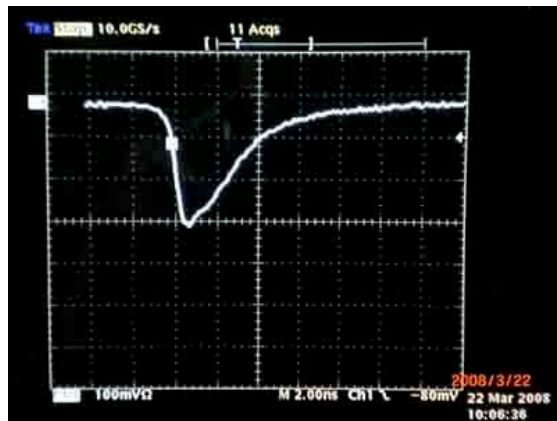

Pulser output(neg) 8.5kV peak

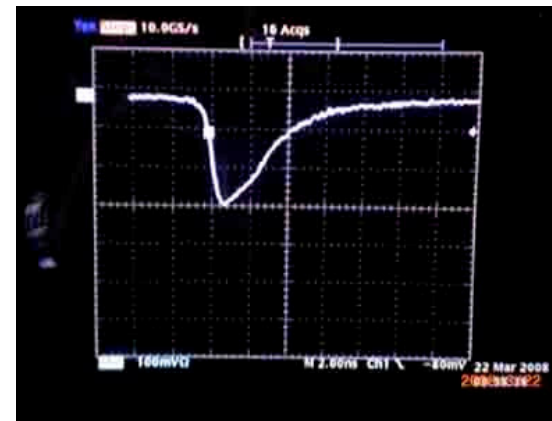

Strip-line output(neg)

A 10kV pulse could be applied for each electrode without any deterioration to the waveform of the pulser, which means no-discharge at the connectors and the electrodes.

2008/9/19

# Beam kick profile from the beam oscillation amplitude

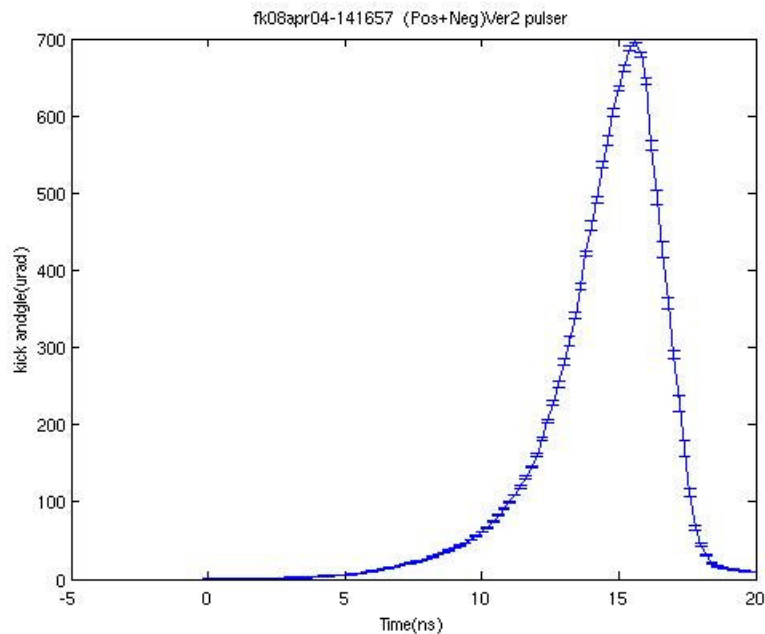
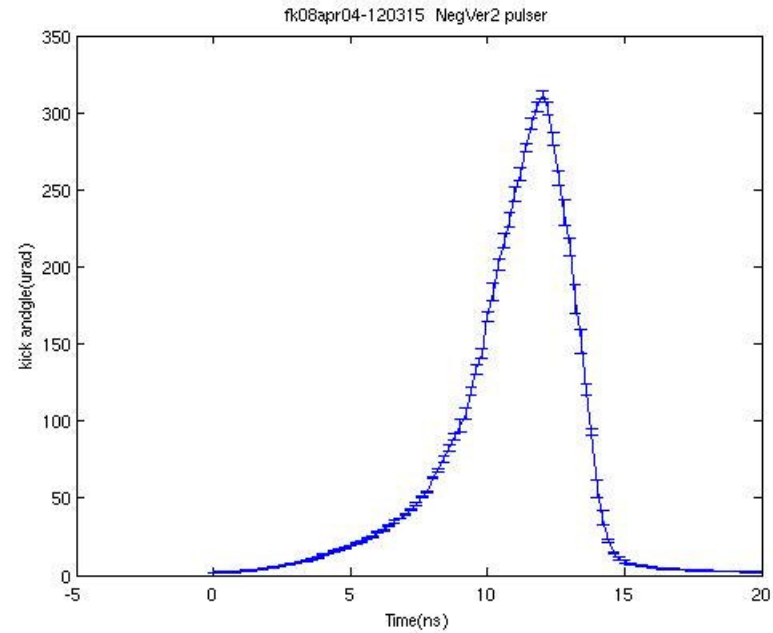
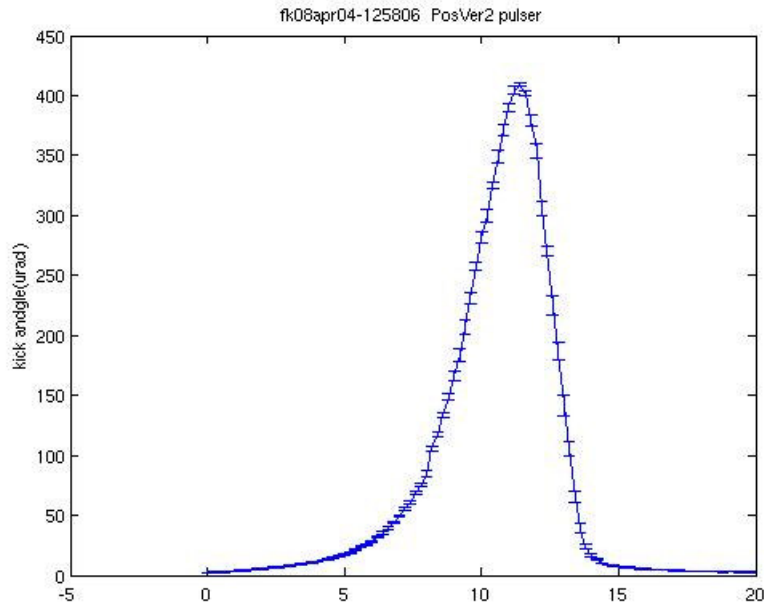

Beam kick test in the DR was carried out. The pictures show the timing scan of the kick pulses for the beam timing in the cases of the Positive, Negative and Pos+Neg pulses. The peak kick angles are 0.4, 0.3 and 0.7mrad, respectively, which agreed with the estimation from the kick voltage and the strip-line dimensions.

# Estimation of kick angle

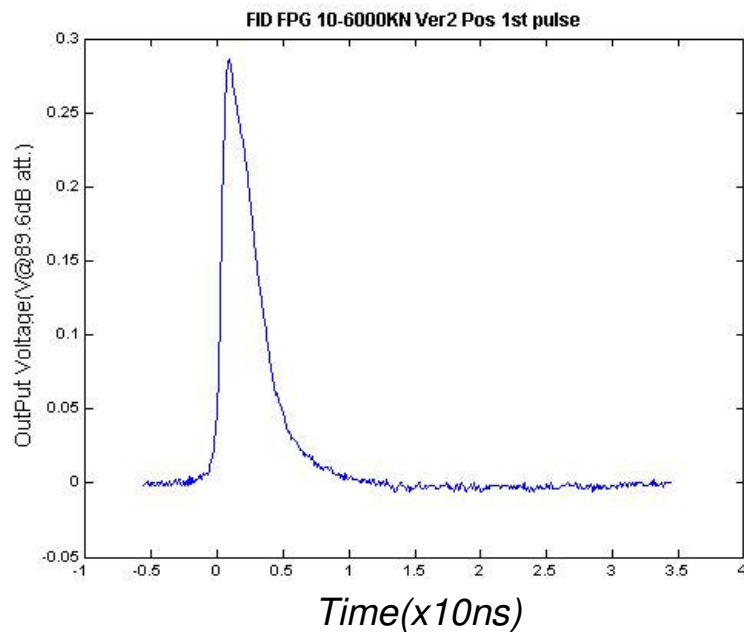

*High Voltage Pulse Waveform*

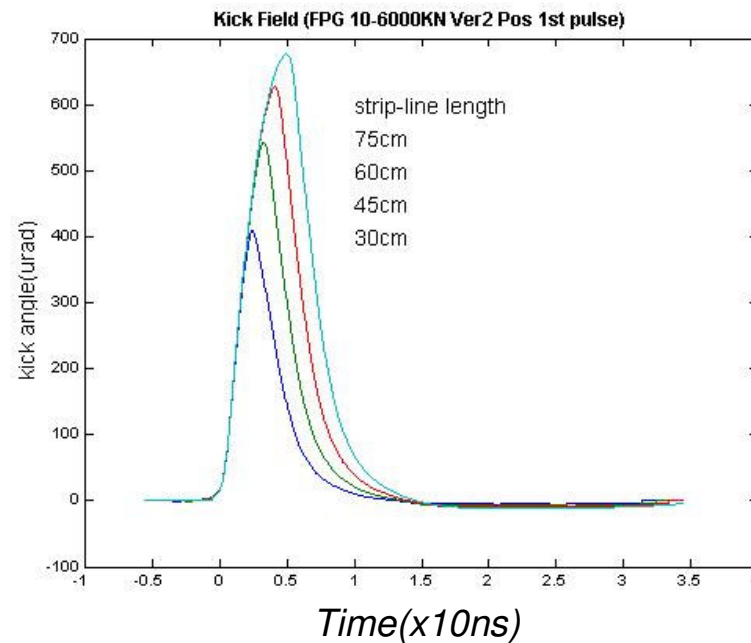

*Calculation of the kick field*

*When a high voltage pulse, upper picture, is applied to the different length of the strip-line, the waveform of the kick field and the kick angle are calculated.*

*In the case of a 60cm long strip-line, the kick angle is  $\sim 0.6$  mrad and the rise time is less than 5ns. When a pair of pulsers(positive/negative) for each strip-line and two unit of 60cm long strip-lines are used, the total kick angle is 2.4mrad.*

# Timing chart of 30 bunches beam extraction

The bump orbit is gradually changed after all of the bunches have been damped. The strip-line kicker kicks out the beams at the timing of the flat-top of the bump orbit. The beams are extracted as one long bunch train, which is a 10micro-sec long with 154ns (or 308 ns) bunch spacing.

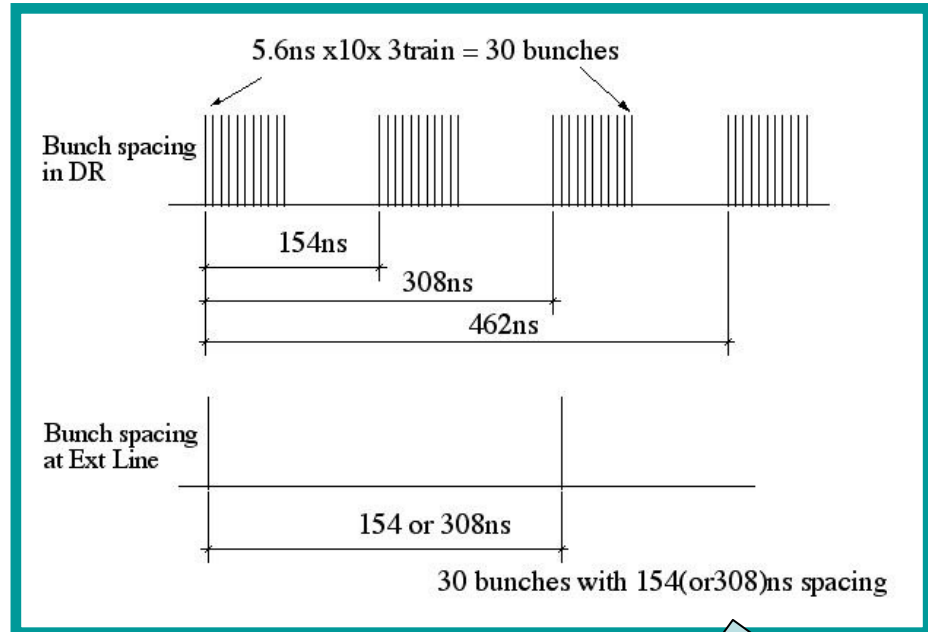

Injection beam

1st Train

2nd Train

3rd Train

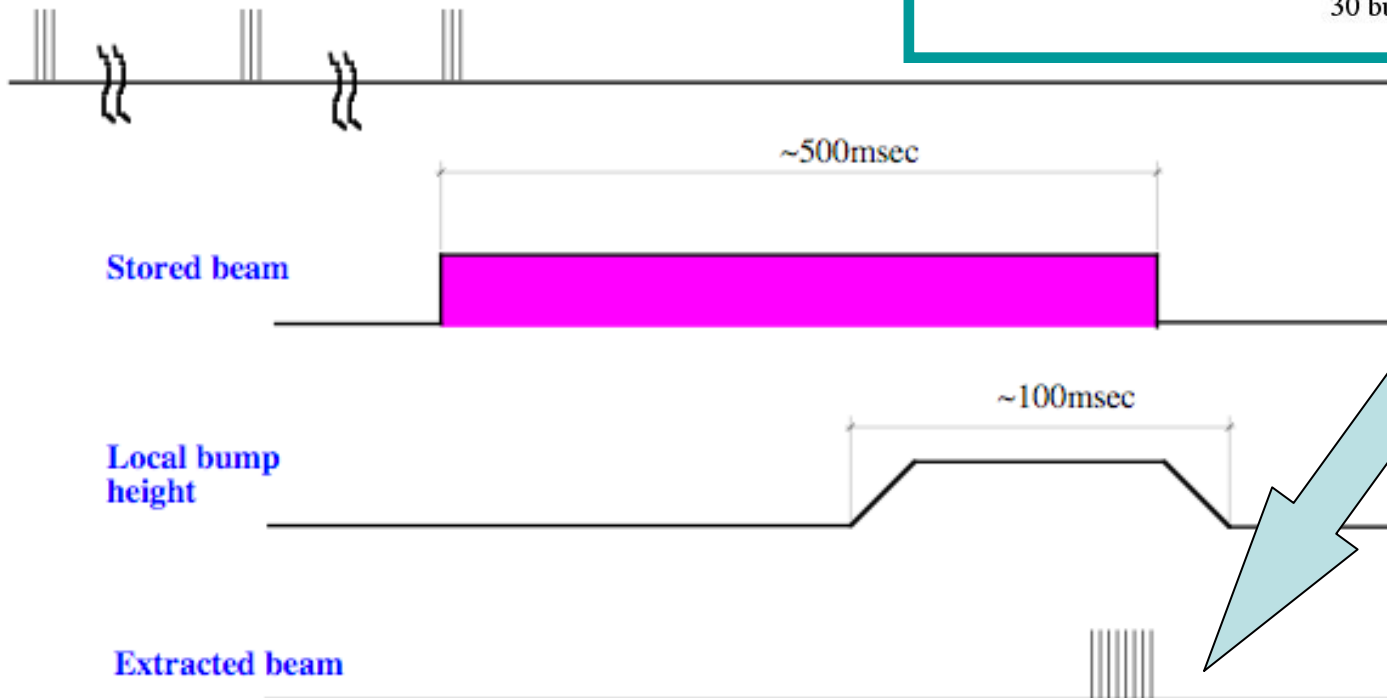

# Optics design of Orbit Bump with 7 Correctors

Auxiliary Septum location

16:04:31 Monday 12/03/2007

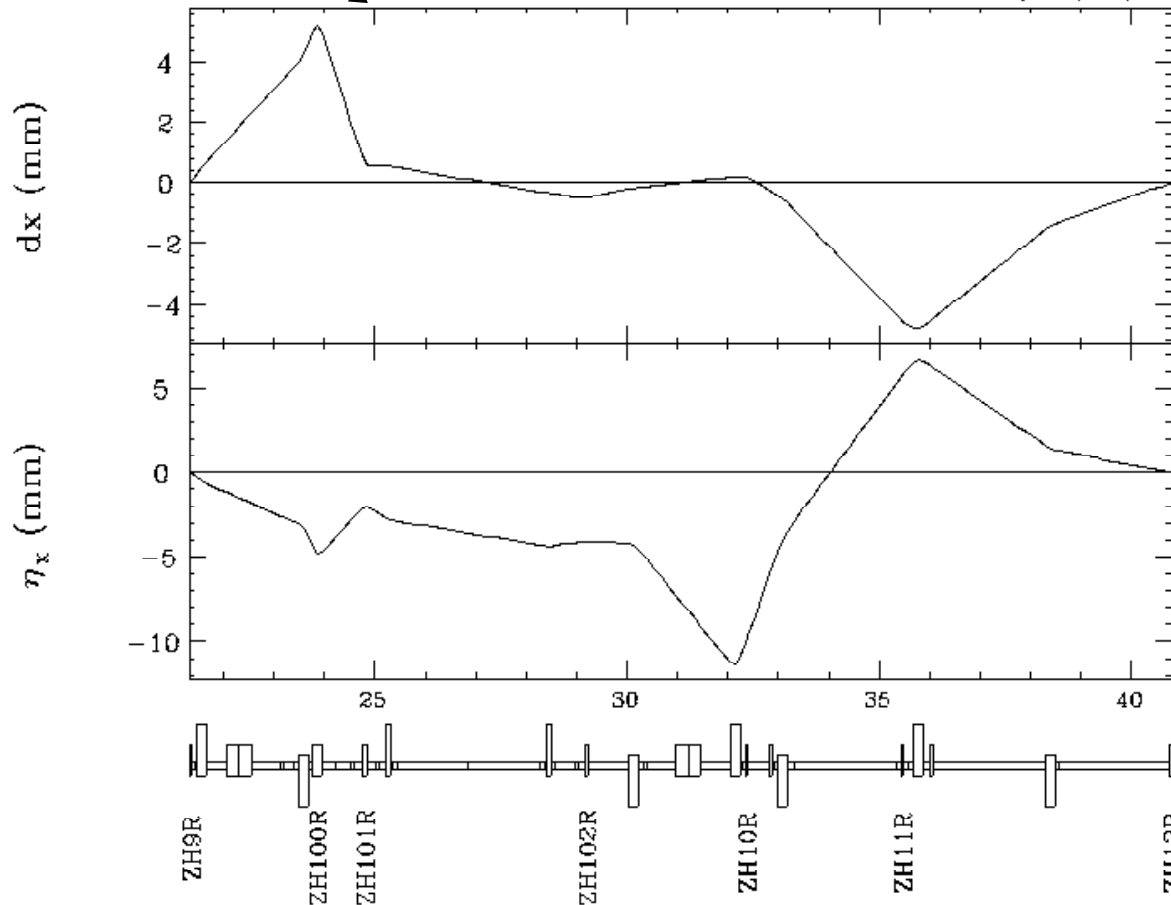

$dx=5\text{mm}@ZH100R$

ZH9R -.002320433716

ZH100R .010028367995

ZH101R -.005102712636

ZH102R -5.52689273E-4

ZH10R .001010243282

ZH11R -7.88468363E-4

ZH12R 5.883103424E-4

**Abs[dx] between septum and INJ.Kicker**

**( from LSEP.1to IIN) < 0.5 mm**

2008/9/19

*S.Kuroda*

# Power Supply Control for Pulse Bump orbit

The pulse current control, which is synchronized with the beam injection, is required for the steering magnets of the local bump orbit to keep a stable beam condition.

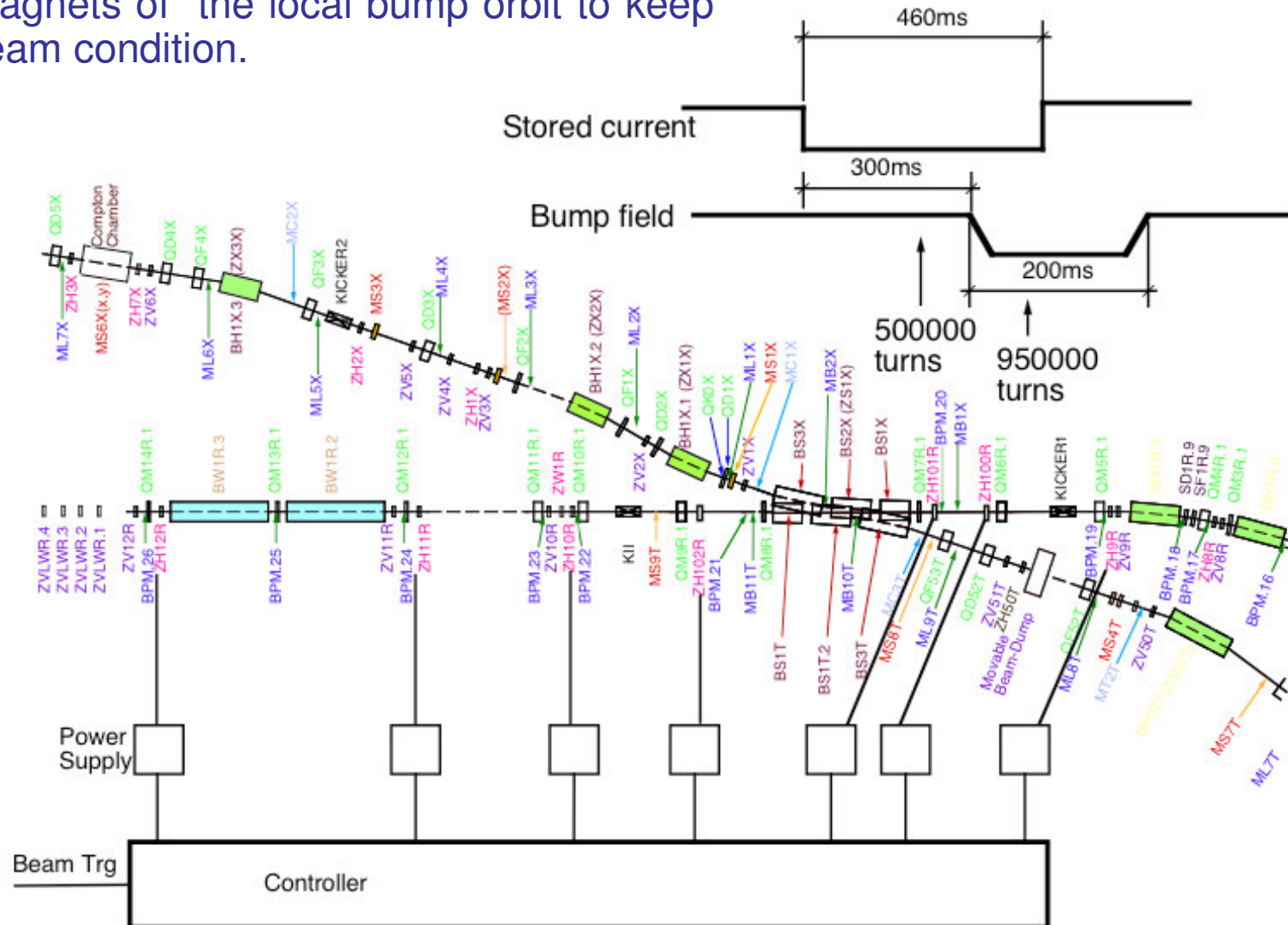

# Detail of power supply control

To avoid the beam loss at the injection timing by the bump orbit, the current control starts 200ms after injection, which correspond to about three damping time. The current ramp needs 120ms to keep the orbit during the ramping time. The beam is extracted at the flattop of the current.

*Injection*      *Extraction*

- Beam Injection
- Bump orbit start
- Current control
- Magnet current



100ms/div



# Bump Orbit Test Result

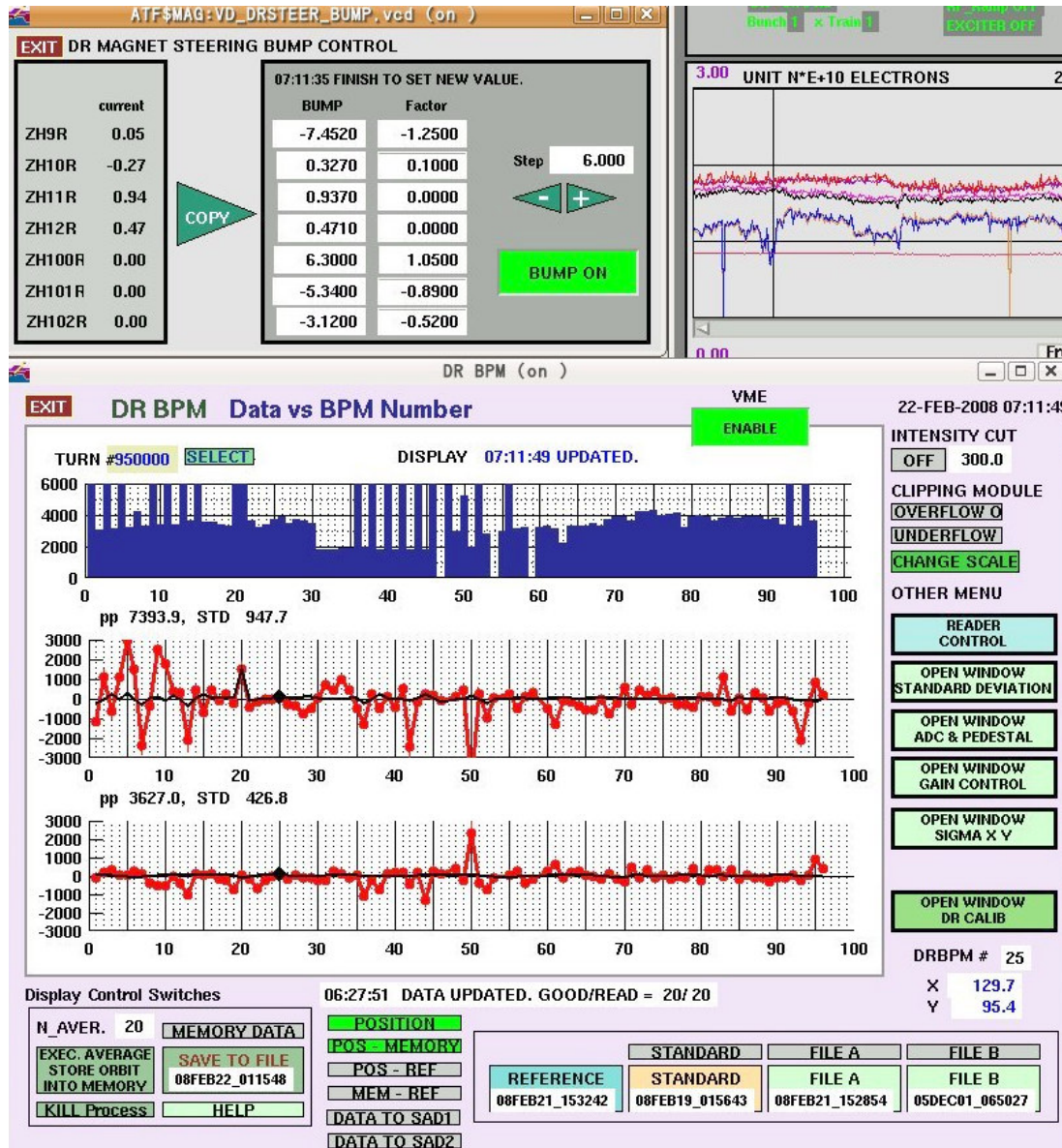

2008/9/19

The height of the bump is confirmed by the displacement at BM20 and the magnet currents.

There is no BPM at the location of the peak of the bump. BPM20 is located at 1m downstream of the peak of the bump. The calculation depicted about 2mm of displacement at the BPM20.

The picture shows the control window and the beam position of the damping ring. The black line in the horizontal beam position shows the displacement by the bump magnet from the COD. The measurement results show good agreement with the calculation and almost no leakage orbit at the other location. The dispersion correction is not enough at this condition.

There was no beam blow up for the vertical emittance and no beam loss at this experiment.

# Pulse train generator

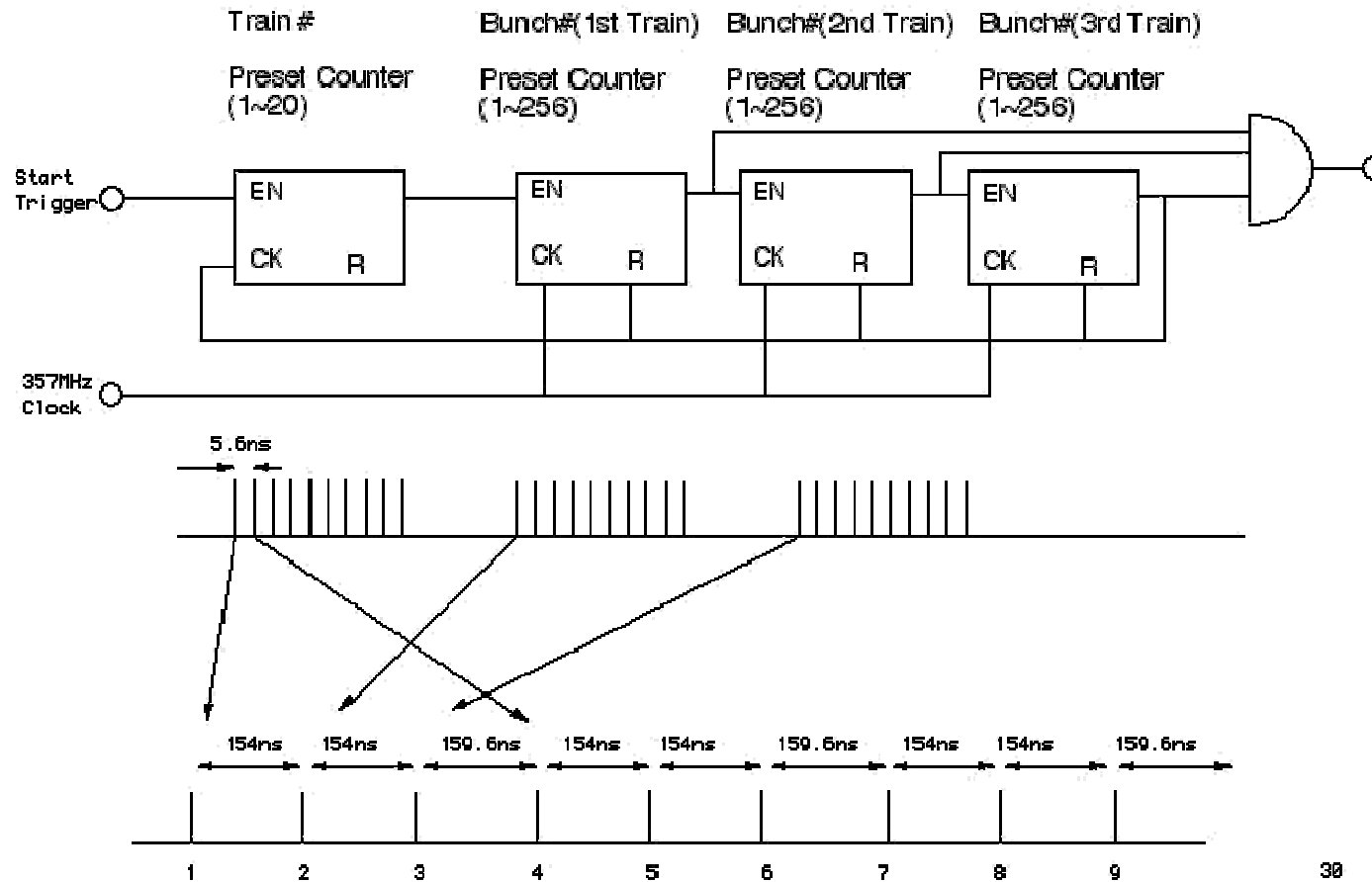

*Special timing pulses are required for the strip-line kicker. The pulse timing needs to shift one bunch spacing every three pulses interval. This circuit is under fabrication.*

# Trigger timing FB for Strip-line kicker

20080115 T.Naito

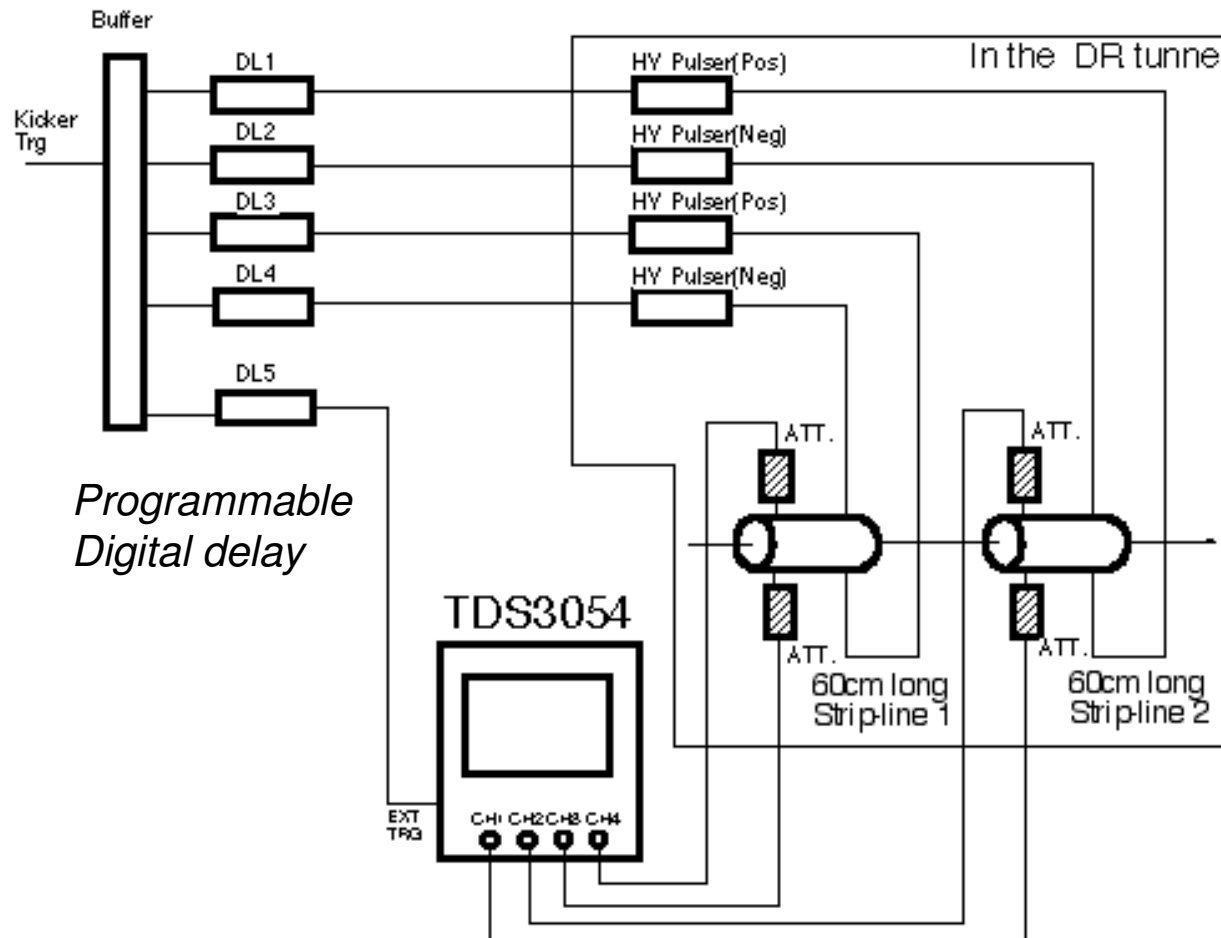

*Precise triggers for each pulser and the timing control is required. The pulse measurement by scope and the timing control by digital delays consist the trigger timing feedback. The step of the digital delay is 60ps. The trigger system could keep the pulse timing in the range of 100ps.*

# Timing drift and the FB result



The graph shows the pulse timing measurement and the delay setting of the feedback system. The pulser output drifted about 600ps in a day, which is compensated less than 200ps except for a bit error of the delay module.

2008/9/19

# Auxiliary septum magnet design and fabrication

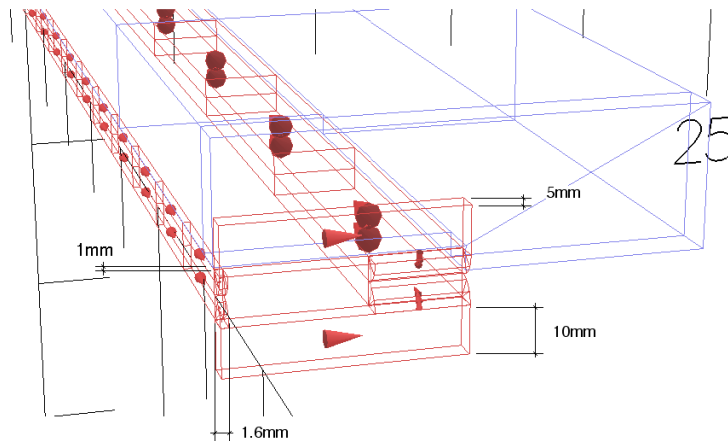
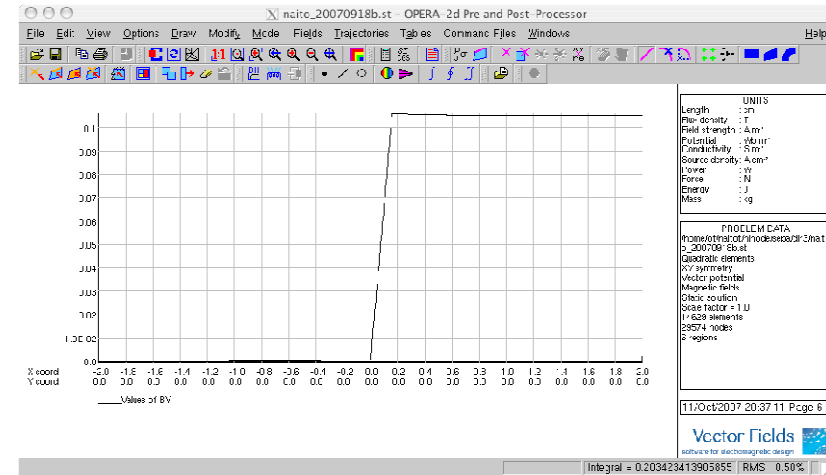
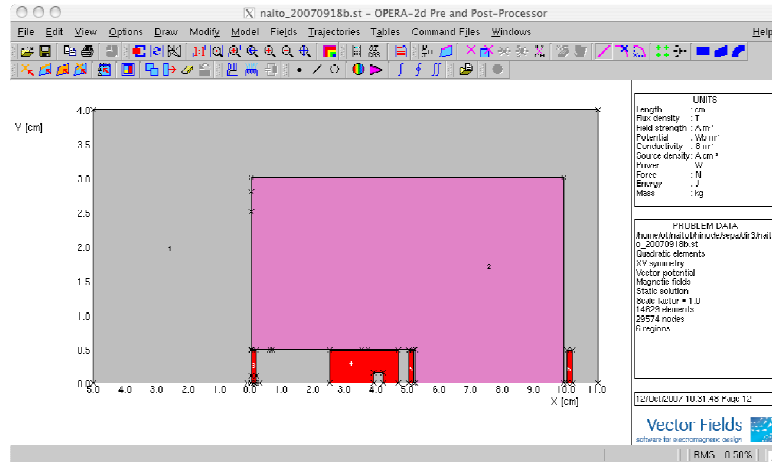

The design work of the auxiliary septum magnet was carried out by using OPERA 2D and 3D.

The designed auxiliary septum magnet has 1.6mm of a thin separator and 0.1T of bending field.

# Auxiliary septum

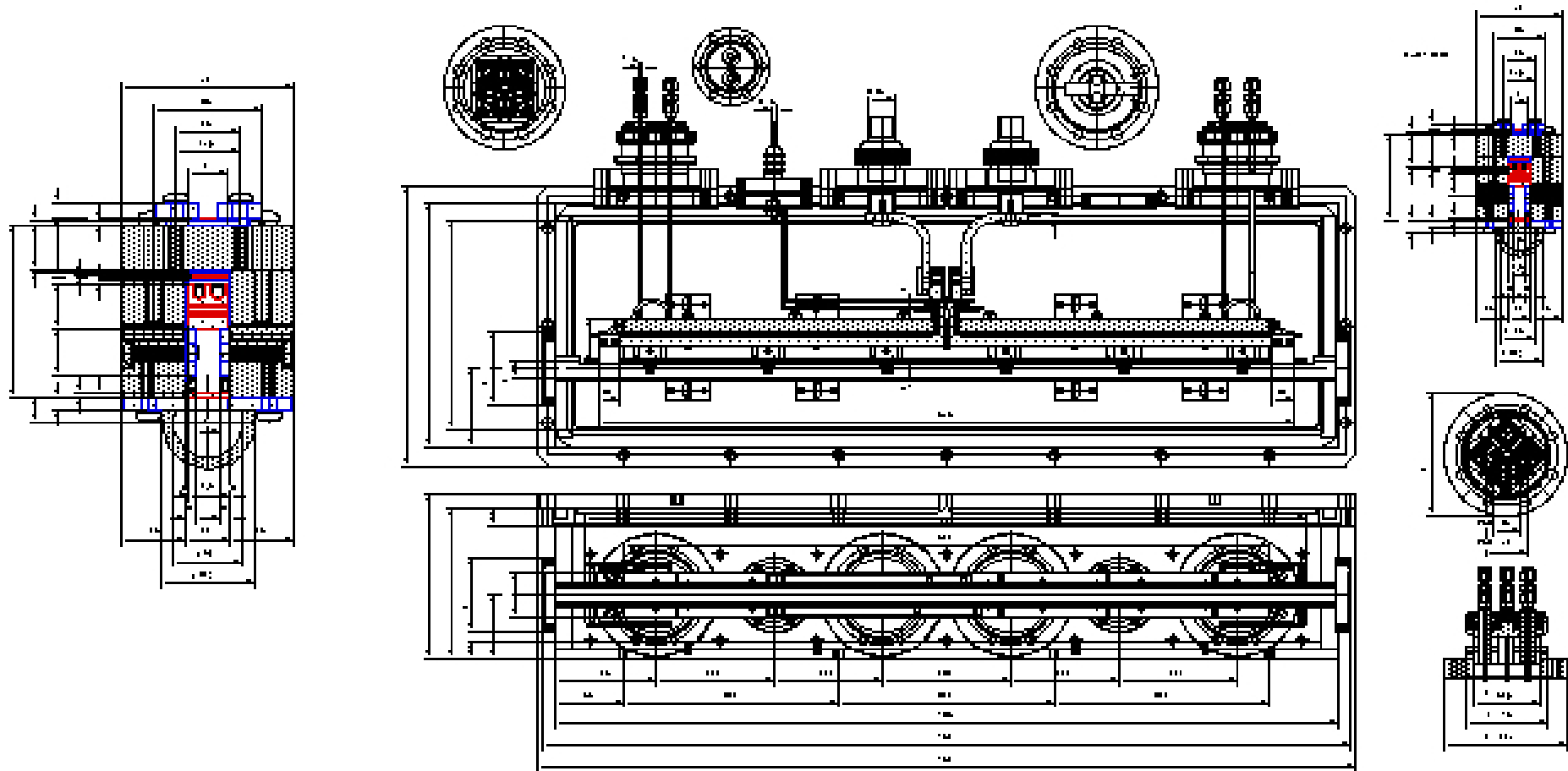

# EXT Orbit with Fast Kicker

*S.Kuroda*

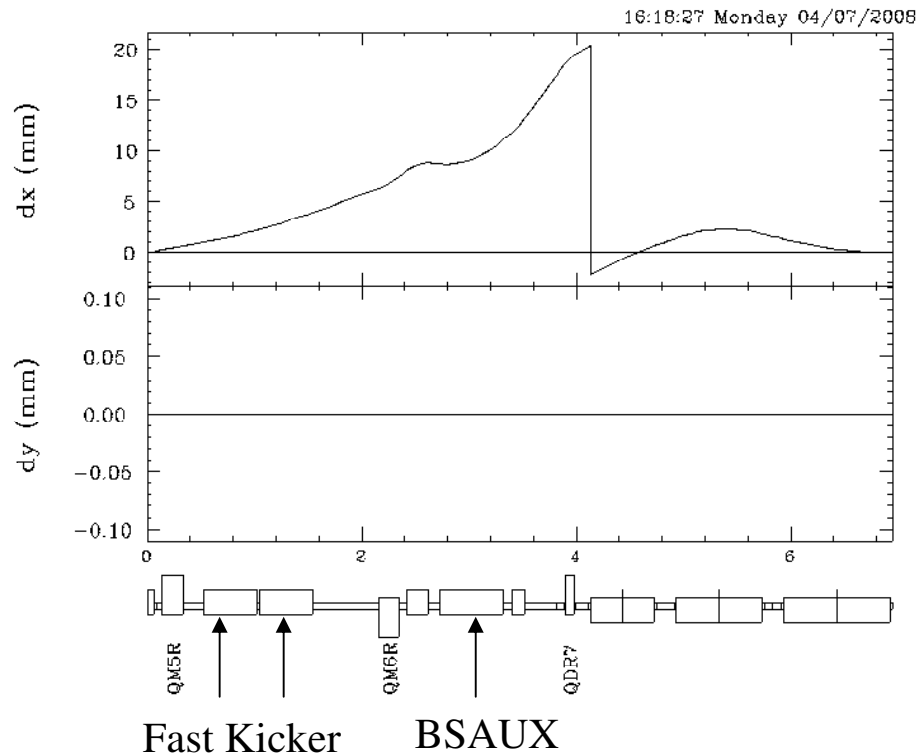

Fast Kicker Strength: 1mrad X 2

Correctors K0: ZH9R -0.002320433716

ZH100R 0.009876184722

ZH101R -0.005210348744

Free parameters; K0 of BSAUX, BS1-3X

Imposed Condition;

Abs[dx] < 3 mm in BS1-3X region

dx=dpx=0 at the end of BS3X

Results;

BSAUX K0=-.010280163677

BS1X K0 =.0011826626821

BS2X K0 =.0031361169236

BS3X K0 =-.0013134448462

BS1&2X is weaker by 8.4%, BS3X is stronger by 1.1%.

Orbit is measured from  
DR design orbit  
+ toward EXT

Orbit is measured from  
EXT design orbit  
- toward DR

2008/9/19

Physical aperture in septum region  
must be larger than  
3mm+orbit distortion(+beam size)<sup>23</sup>

# Beam extraction components

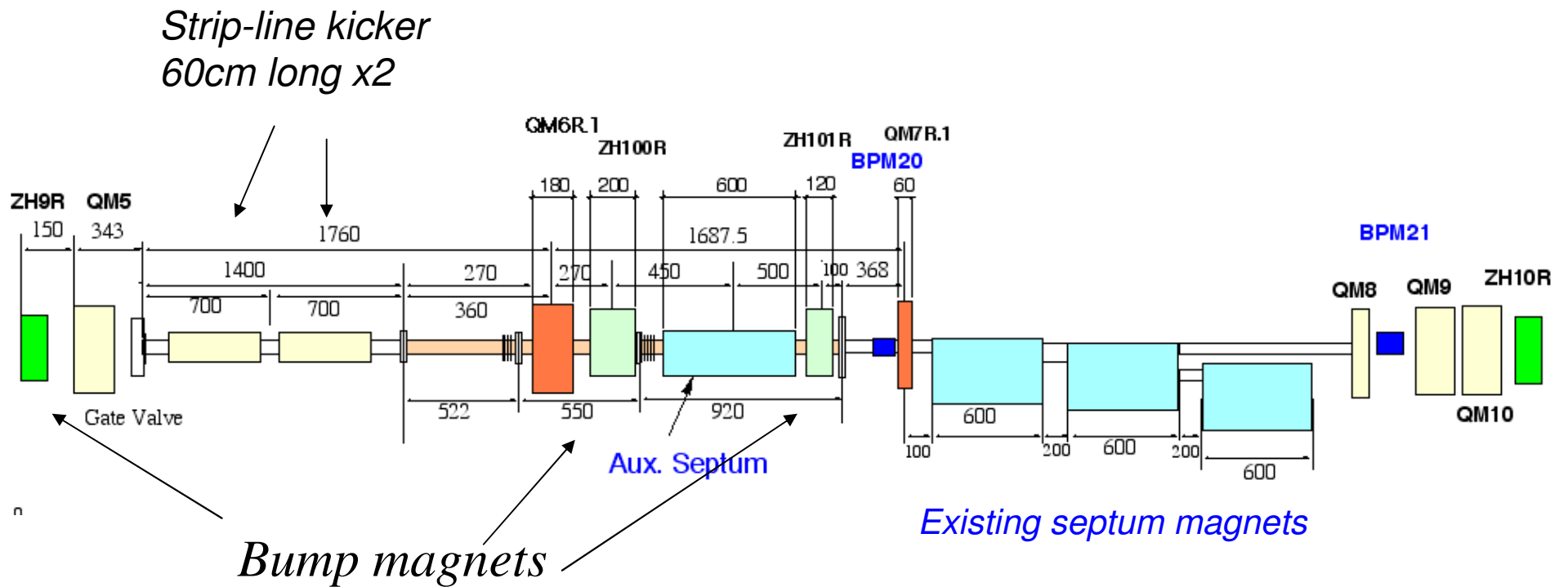



## ***Beam Extraction Test Schedule***

- Local bump orbit test Jan 2008
- 10kV fast pulser March 2008
- Fabrication of strip-line electrodes (60cm) November 2008
- Fabrication of Auxiliary Septum magnet October 2008
- Installation of strip-line and septum December 2008
- Beam extraction test Jan 2009

*Vacuum work, etc. 1 week*  
*Beam extraction test 2 weeks*