

ILC Damping Rings R&D at the Cockcroft Institute

Andy Wolski, Maxim Korostelev, Kosmas Panagiotidis

University of Liverpool Department of Physics

Oleg Malyshev

STFC/ASTeC

Norbert Collomb, John Lucas

STFC/Technology

ILC Damping Rings WebEx Meeting

22 June 2009

Research Goals

Lattice design (MK)

- Make necessary modifications and improvements to the present 6.4 km baseline lattice.
- Develop designs for the injection/extraction lines.

Vacuum system technical design and costing (OM/NC/JL)

- Develop technical design for vacuum system and magnet supports.
- Produce costing based on technical design.

Impedance model (MK)

- Develop impedance model based on technical design of vacuum system.
- Evaluate impact of impedance on beam dynamics.

Low-emittance tuning (KP)

- Evaluate techniques for low-emittance tuning based on experience at ATF, CsrTA, and other machines.
- Specify requirements for diagnostics and correction systems.

Lattice Design

- **Circumference of the DCO3 ring is the same as for DCO2 (6476.4 m, harmonic number 14042).**
- Total number of quads in the DCO3 ring is the same as for the DCO2 ring (690).
- Four additional arc cells are inserted in each arc, resulting in a total of 200 arc cells.
- **Injection and extraction sections are in one straight, with reflection symmetry.**
- FODO cells are inserted between the extraction and chicane to adjust both straights to the same length.
- All RF cavities (20 units) and wigglers (88 units) are in a single straight, opposite to the injection/extraction straight. This allows localization of the cryogenics system.
- RF cavities for the e+ ring and for the e- ring do not overlap each other.
- The circumference chicane is located downstream of the RF section to avoid synchrotron radiation into the RF cavities.
- Doglegs are absent in DCO3 design.
- On and off momentum dynamic aperture in the DCO3 lattice is a little larger than in the DCO2 lattice.
- Phase advance per arc cell can vary from 72 to 108 degrees but at horizontal phase advances higher than 104 degrees, DA becomes relatively small.

Lattice Design

DCO2

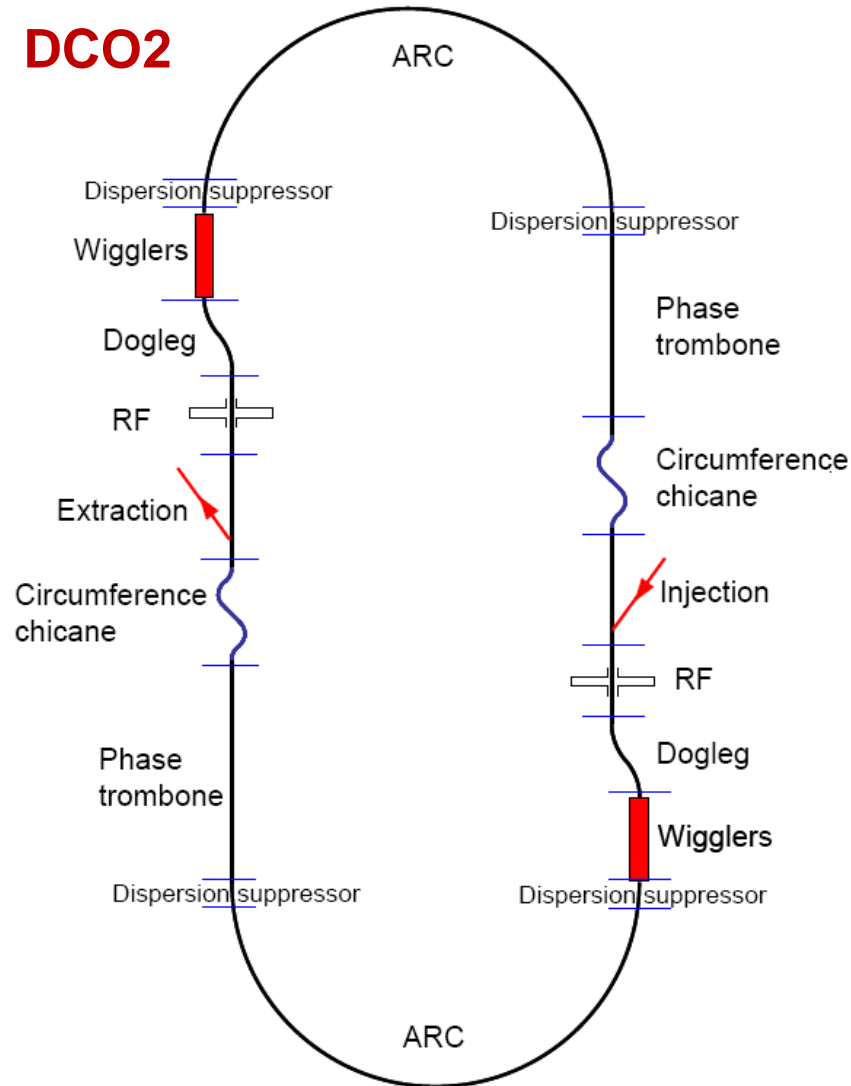

DCO3

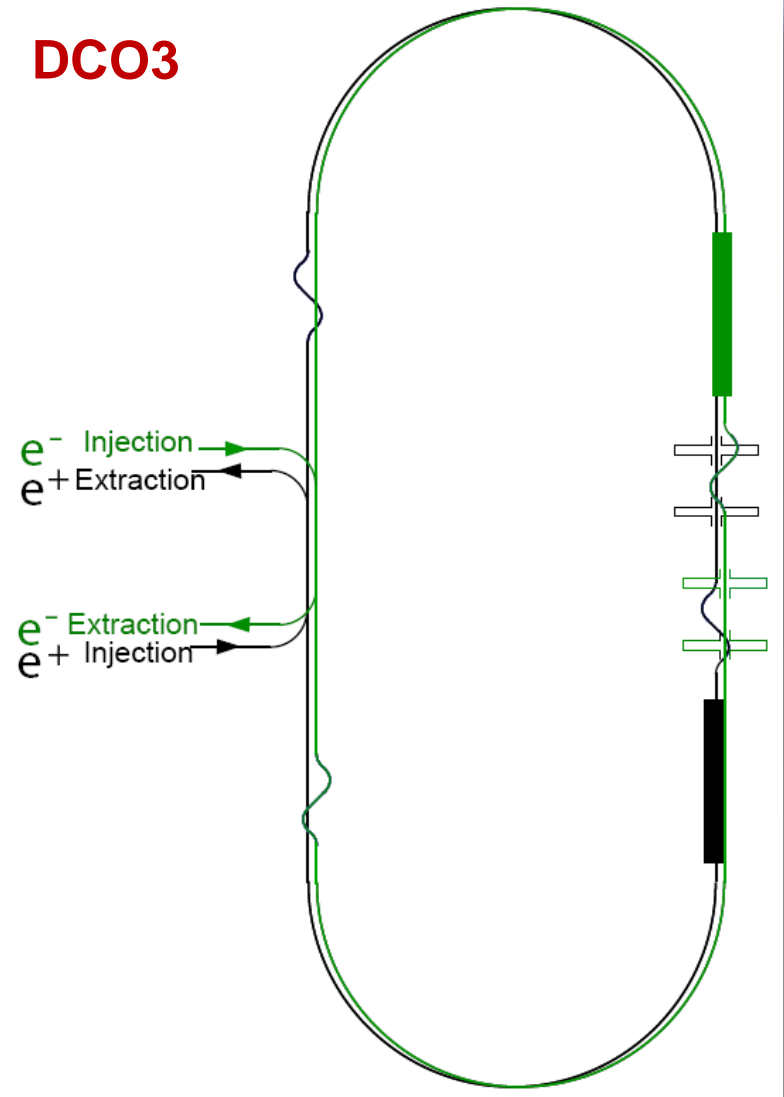

DCO2 and DCO3 Parameters

| | | |
|--------------------------|--------------------------|--------------------------|
| Beam energy | 5 GeV | 5 GeV |
| Circumference | 6476.4 m | 6476.4 m |
| RF frequency | 650 MHz | 650 MHz |
| Harmonic number | 14042 | 14042 |
| Transverse damping time | 21.0 ms | 21.1 ms |
| Type and # of arc cells | FODO with one dipole 192 | FODO with one dipole 200 |
| Total length of wigglers | 215.6 m | 215.6 m |
| Wiggler peak field | 1.6 T | 1.6 T |
| Relative damping factor | 9.7 | 10.08 |
| Energy loss per turn | 10.3 MeV/turn | 10.23 MeV/turn |

| Phase advance per arc cell | 72° | 90° | 100° | 72° | 90° | 100° |
|-----------------------------|-----------------------|-----------------------|-----------------------|-----------------------|-----------------------|-----------------------|
| Momentum compaction | 2.8×10^{-4} | 1.7×10^{-4} | 1.3×10^{-4} | 2.9×10^{-4} | 1.6×10^{-4} | 1.3×10^{-4} |
| Normalized horiz. emittance | 6.6 μm | 4.7 μm | 4.3 μm | 6.4 μm | 4.4 μm | 3.9 μm |
| RMS bunch length | 6.0 mm | 6.0 mm | 6.0 mm | 6.0 mm | 6.0 mm | 6.0 mm |
| RMS energy spread | 1.27×10^{-3} | 1.27×10^{-3} | 1.27×10^{-3} | 1.27×10^{-3} | 1.27×10^{-3} | 1.27×10^{-3} |
| RF voltage | 31.6 MV | 21.1 MV | 17.2 MV | 32.6 MV | 20.4 MV | 17.2 MV |
| RF acceptance | 2.35 % | 1.99 % | 1.72 % | 2.38 % | 1.96 % | 1.74 % |
| Synchrotron tune | 0.061 | 0.038 | 0.028 | 0.063 | 0.036 | 0.028 |
| Horizontal betatron tune | 64.12 | 75.12 | 78.12 | 61.12 | 71.12 | 76.12 |
| Natural horiz. chromaticity | -76.2 | -95.1 | -105.4 | -68.5 | -87.6 | -99.3 |
| Vertical betatron tune | 61.41 | 71.41 | 75.41 | 61.41 | 71.41 | 76.41 |
| Natural vert. chromaticity | -74.7 | -93.4 | -104.0 | -70.2 | -89.2 | -100.7 |

Dynamic Aperture: 72° Arc Cell

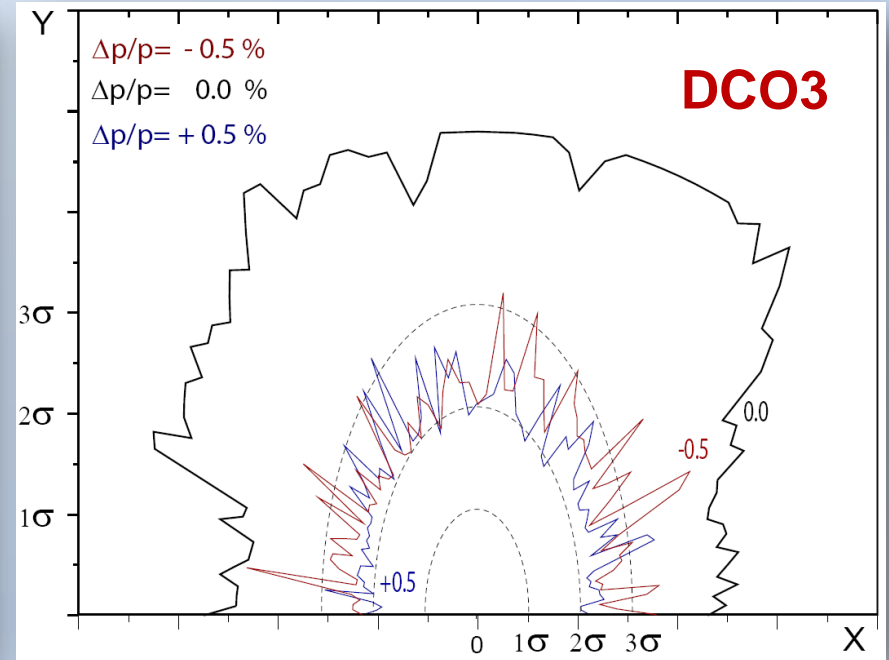
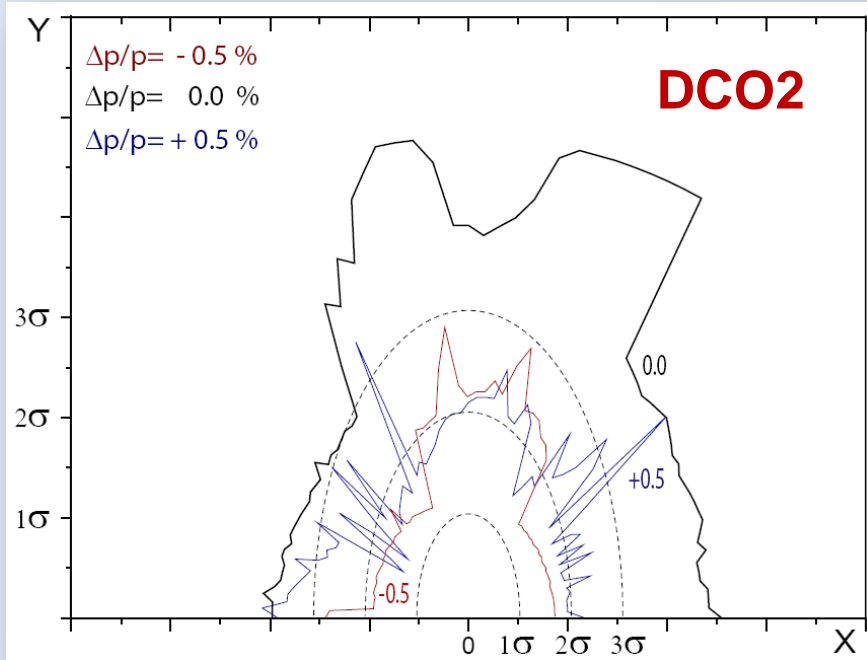

Larger phase advance gives smaller dynamic aperture.

Dynamic aperture in DCO3 appears to be acceptable up to about 100° .

Vacuum System Technical Design and Costing

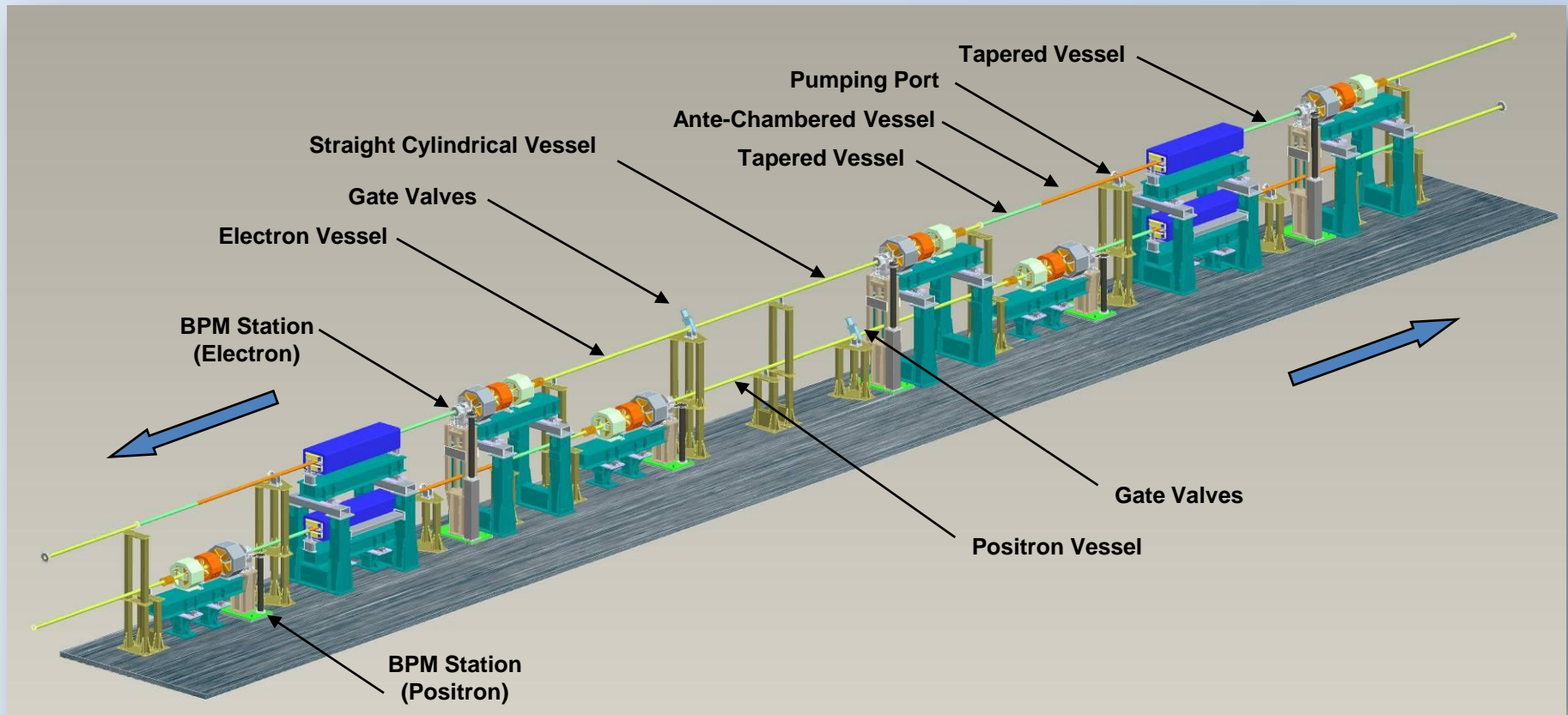

Arc cell technical design is complete (to the appropriate level of detail).

Quotes have been obtained from a variety of sources; costing information is presently being compiled, and will be entered in ICET soon.

Impedance Model

M. Korostelev, et al, "Beam coupling impedance in the ILC damping rings," proceedings PAC'09.

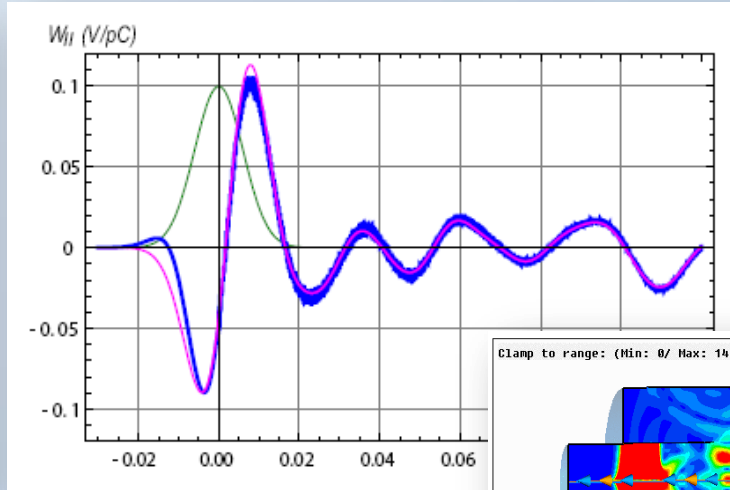
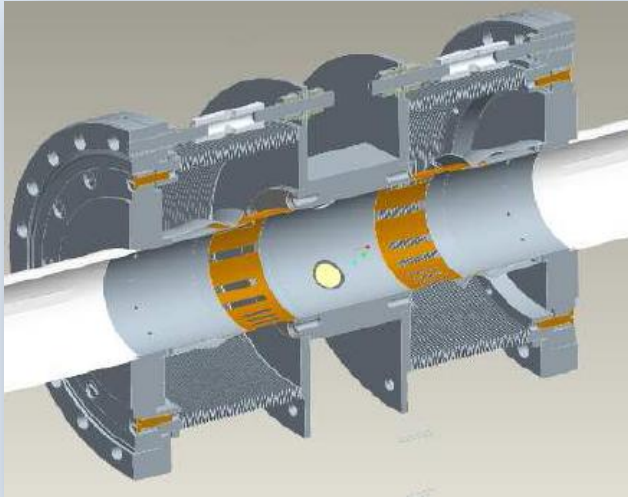

Original bpm model.

Wake function calculated from wake field computed using Microwave Studio.

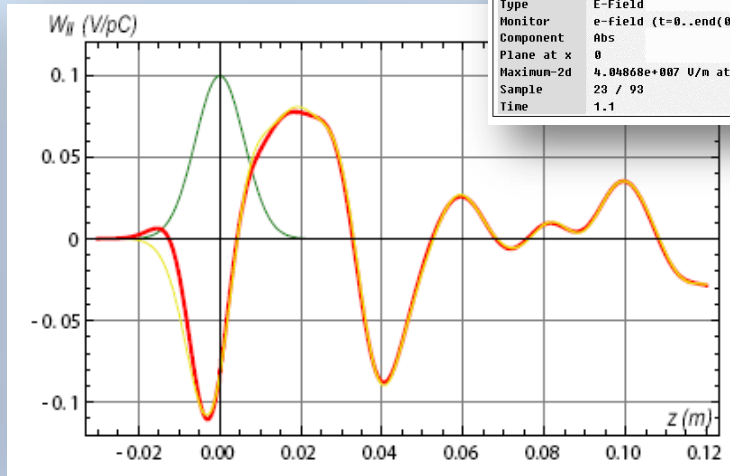
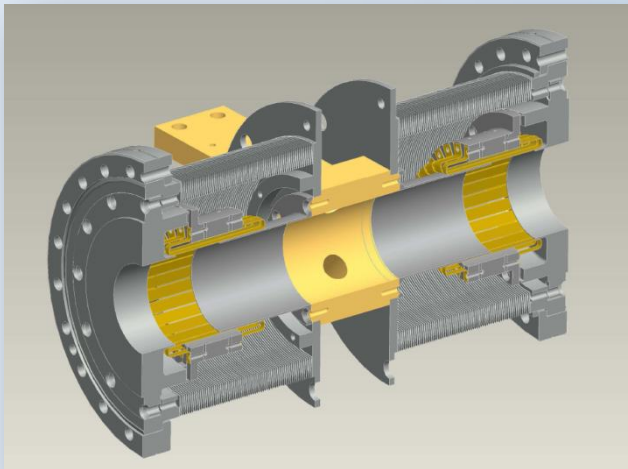
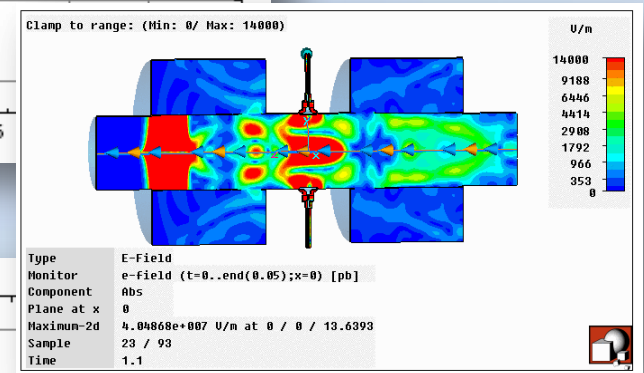

New bpm model (rf shield/bellows based on INFN-LNF design).

Potential Well Distortion

Simulations of longitudinal dynamics are being carried out using a parallel tracking code with 10^6 macroparticles.

Below the instability threshold, the equilibrium distribution from the tracking code can be compared with the profile obtained by solving the Haissinski equations.

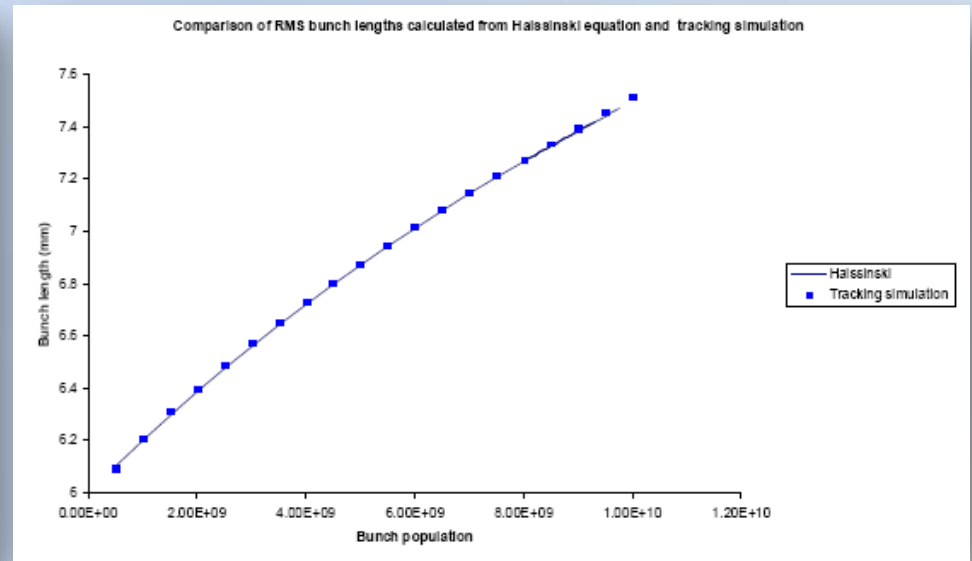
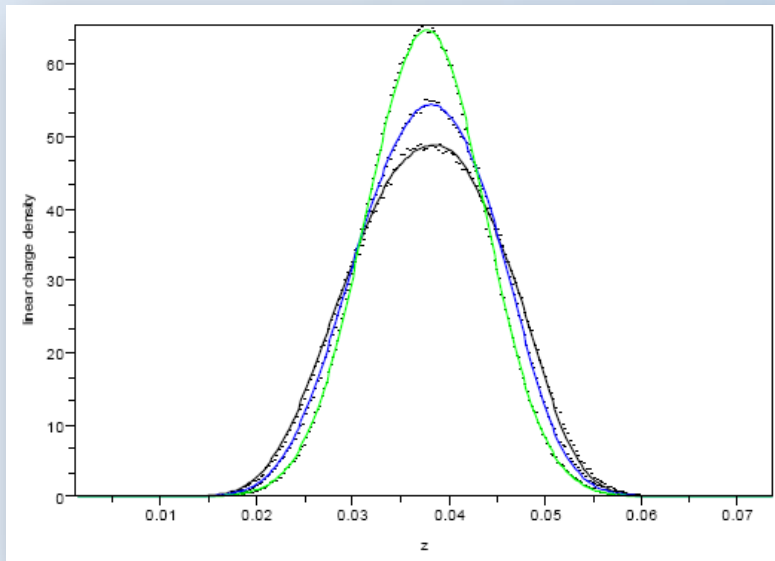

Beam Instability Threshold

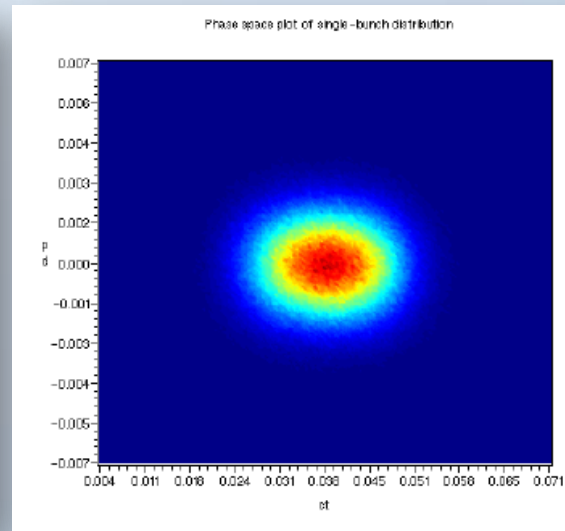
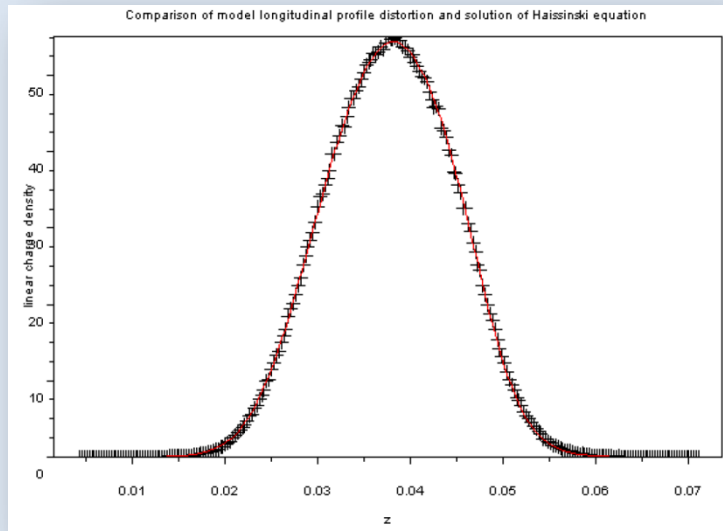

So far, simulations have been run only for an obsolete impedance model, and with 690 bpms: the instability threshold in this case is around 10^{10} particles per bunch.

Top: bunch population 0.5×10^{10} .

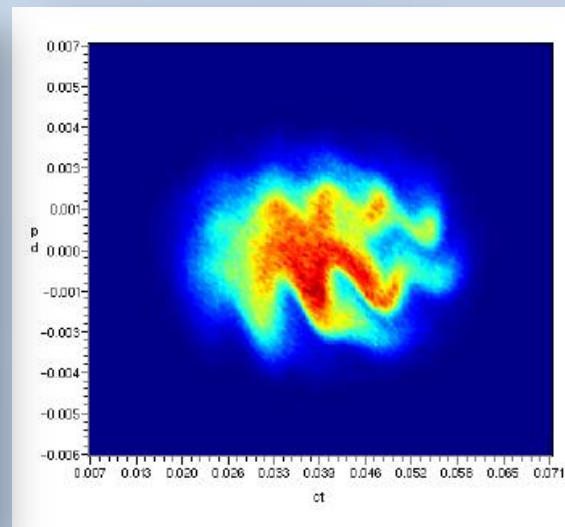
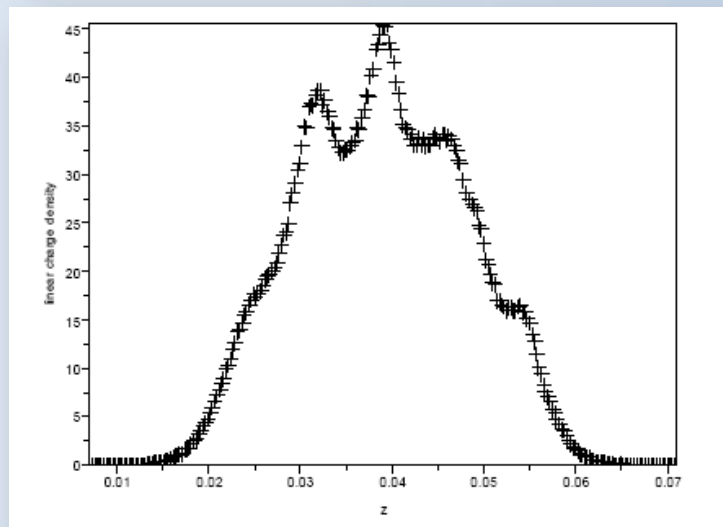

Bottom: bunch population 2.0×10^{10} .

Low Emittance Tuning

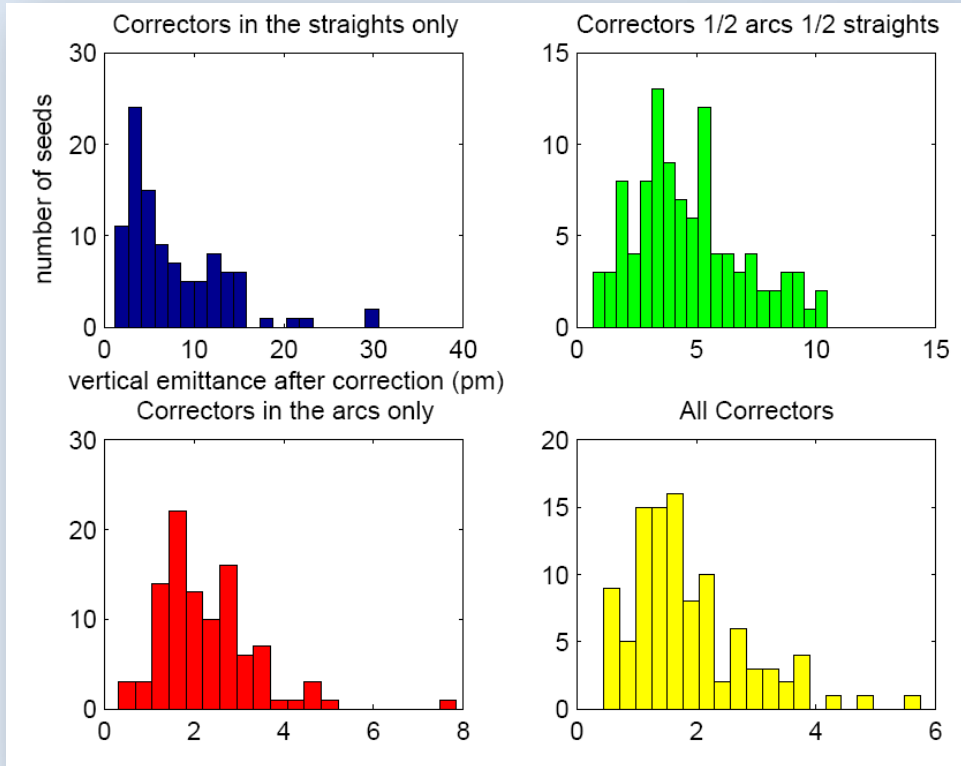

Orbit response matrix analysis has the potential for correcting the emittance in ATF to a few picometres.

Data collection is a time-consuming process: but simulations show that (under ideal conditions) we can reduce the data set by half without significantly impacting the results.

Low-Emittance Tuning

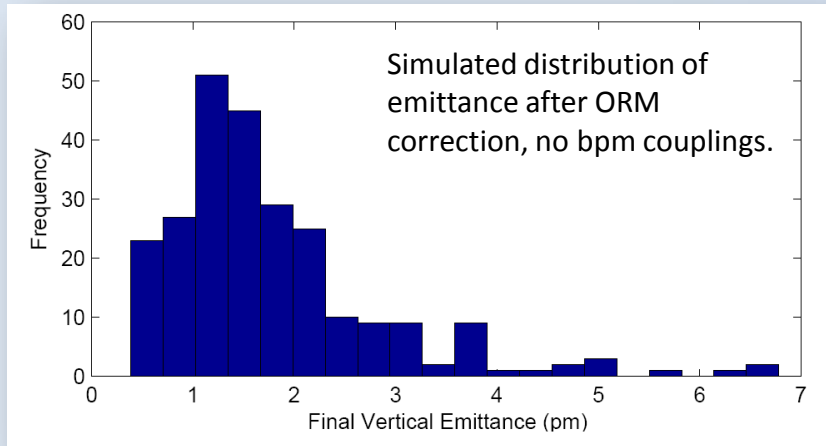

So far, orbit response matrix analysis has not achieved the results we had hoped for.

The reason could be a degeneracy in the ORM data between skew quadrupole strengths and bpm couplings.

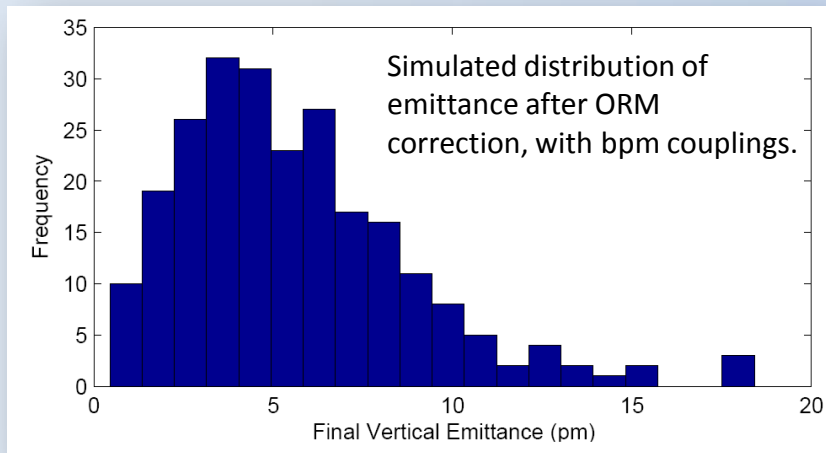

K. Panagiotidis and A. Wolski, "Possible limitations in coupling correction using orbit response matrix analysis," proceedings of PAC'09.

Next steps

Lattice design

- Modified 6.4 km baseline lattice (DCO3) is now essentially complete: minor improvements may be needed.
- We plan to develop designs for the injection/extraction lines: this requires guidance on the overall machine layout.

Vacuum system technical design and costing

- Compilation of the arc cell costing should be completed soon.
- We plan to start developing a technical design for the wiggler sections.

Impedance model

- Work on construction of an impedance model, and understanding the impact on the beam dynamics, is on-going.

Low-emittance tuning

- Recent work has led to a better understanding of the limitations of low-emittance tuning at ATF.
- We plan to complete our studies on the application of various tuning techniques to the ILC damping rings, and specification of the coupling correction system, by the end of this year.