



ILC Damping Rings: Engineering Model and Vacuum System Design

Norbert Collomb¹, Alan Grant¹, Maxim Korostelev², John Lucas¹,
Oleg Malyshev³, Alex Thorley², Andy Wolski².

¹*STFC Technology, UK*

²*University of Liverpool and the Cockcroft Institute, UK*

³*STFC/ASTeC and the Cockcroft Institute, UK*

ILC Damping Rings Collaboration WebEx
22 October 2008



Outline

- In these slides, we describe progress with:
 - **the engineering model for the damping rings, using the present baseline configuration and lattice;**
 - **design of the vacuum system;**
 - **studies of short-range wake fields (impedance modelling, and estimates of higher-order mode heating, potential well distortion, and longitudinal instability threshold.)**
- The engineering design and vacuum studies will provide essential information for:
 - **developing an improved cost estimate, and identifying cost drivers and potential for cost savings;**
 - **progressing design work for a range of subsystems, including magnets, magnet supports, conventional facilities, alignment...**
 - **understanding critical beam dynamics issues, including electron cloud, ion effects, acceptance, and low-emittance tuning.**



DCO lattice: structure and layout

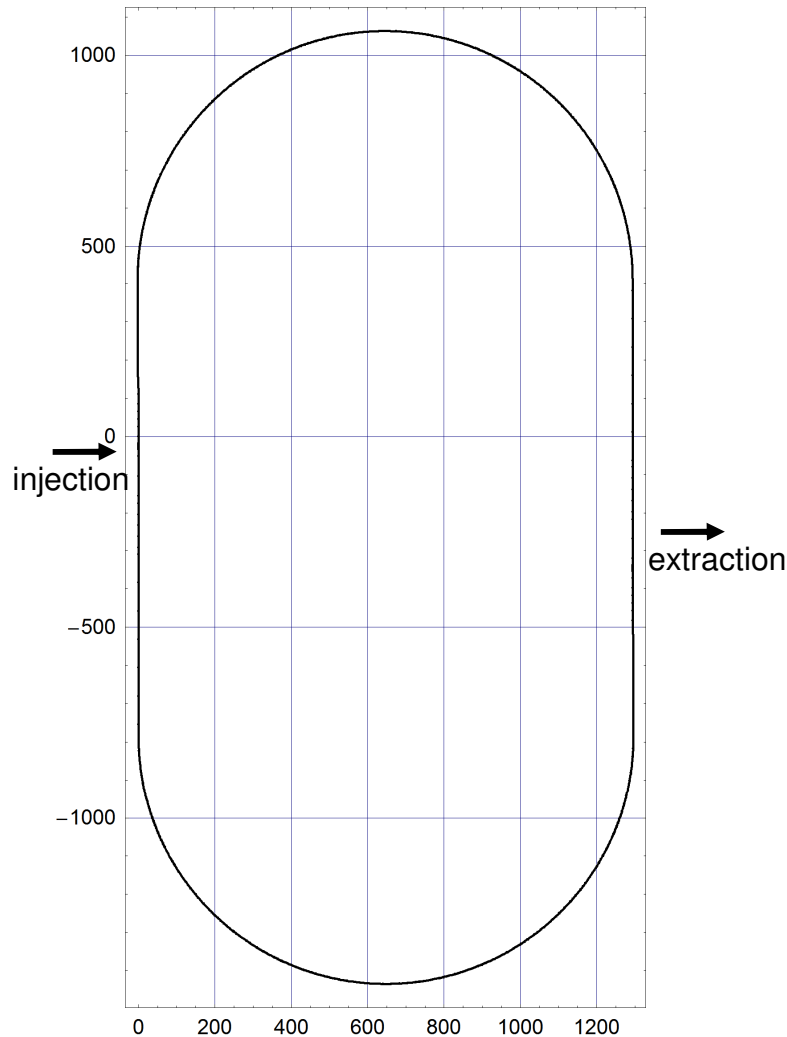

- Arcs consist of a total of 192 FODO cells
- Flexibility in tuning momentum compaction factor, given by phase advance per arc cell:
 - **72° phase advance:** $\alpha_p=2.8\times 10^{-4}$
 - **90° phase advance:** $\alpha_p=1.7\times 10^{-4}$
 - **100° phase advance:** $\alpha_p=1.3\times 10^{-4}$
- No changes in dipole strengths needed for different working points.
- Racetrack structure has two similar straights containing:
 - **injection and extraction in opposite straights**
 - **phase trombones**
 - **circumference chicanes**
 - **rf cavities**
 - **"doglegs" to separate wiggler from rf and other systems**
 - **wiggler**



Engineering model

- Work by John Lucas, Norbert Collomb, Alan Grant (STFC Technology).
- Developing a CAD model for mechanical integration of vacuum system, BPMs, magnets and supports.
- Goals:
 - to demonstrate engineering feasibility of lattice design;
 - to provide a basis for further design and beam dynamics studies and costing of vacuum, magnets, conventional facilities, etc.

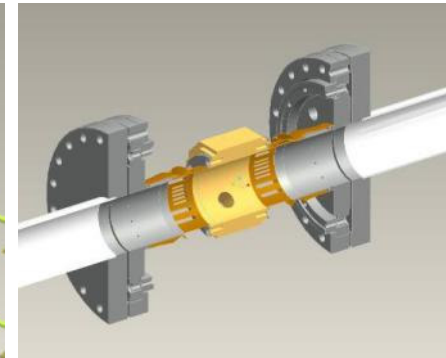
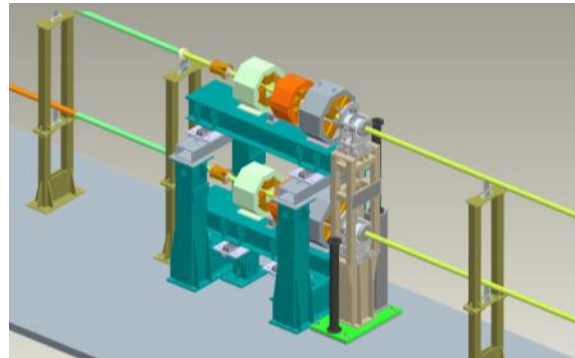
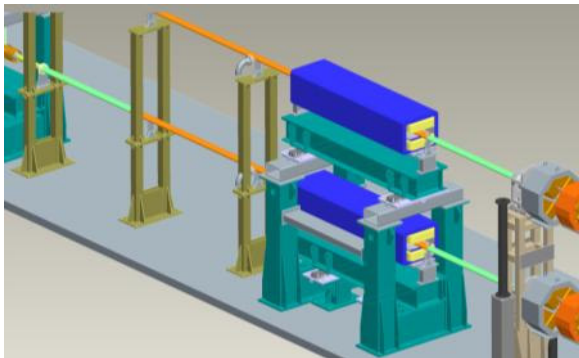



Vacuum system

- Work by Oleg Malyshev (STFC/ASTeC).
- Specifying chamber geometry, pumping technology, various components (flanges, bellows, valves...)
- Goals:
 - **to provide a basis for assessment of technical performance (including effects such as ion-induced pressure instability) and costing;**
 - **to provide a basis for design of other subsystems, such as magnets;**
 - **to provide a basis for beam dynamics studies, including electron cloud and ion effects, impedance effects, acceptance.**



Impedance modelling and instabilities

- Work by Maxim Korostelev and Alex Thorley (Liverpool/Cockcroft).
- Developing an impedance model based on technical designs of vacuum system components (BPMs, bellows, tapers...)
- The goal is to guide the vacuum system design, to ensure a sufficiently low impedance for operation safely below instability thresholds.

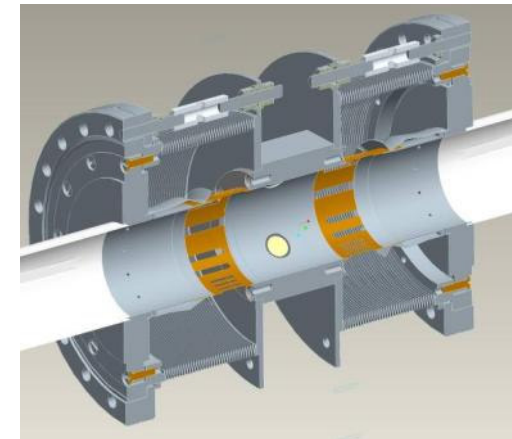
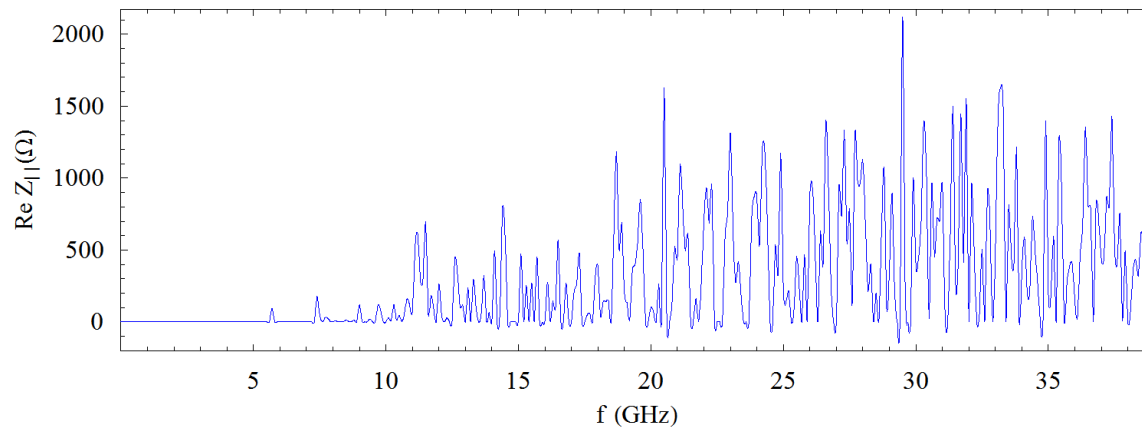



Other studies

- Long-range wake fields and jitter effects
 - Work by Kai Hock (Liverpool/Cockcroft)
 - Goals: to assess impact of long-range wake fields, specify requirements for bunch-by-bunch feedback systems, and estimate bunch-to-bunch jitter on the beam extracted from the damping rings.
- Low-emittance tuning
 - Work by James Jones (STFC/ASTeC) and Kosmas Panagiotidis (Liverpool/Cockcroft)
 - Goals: to specify requirements on alignment and stabilisation, design of low-emittance tuning system (numbers, locations, functionality and performance of instrumentation including BPMs and correctors), and develop effective low-emittance tuning techniques.



Engineering model: key features

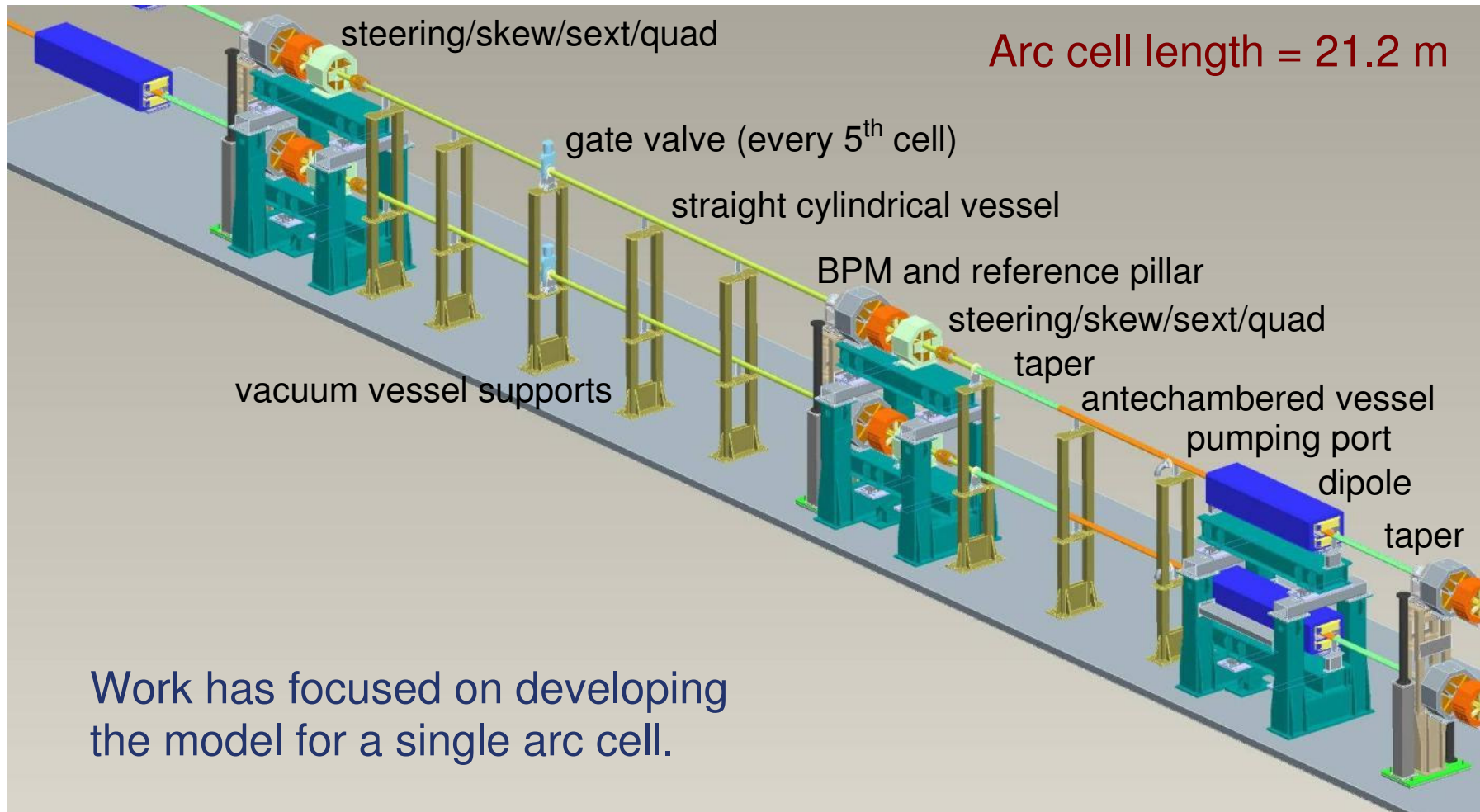

Work has focused on developing the model for a single arc cell.



Vacuum system: key features

- Pumping provided by NEG coating.
 - **Cost-effective solution for achieving the demanding vacuum levels needed to avoid ion instabilities.**
 - **Only one (small) ion pump required per arc cell, located downstream of the dipole.**
- "In-situ bake-out" system provided for activation of NEG coating (by heating to 180°C).
 - **Bellows and "sliding" chamber supports allow for thermal expansion.**
- Vacuum chamber supported independently from magnets.
 - **The aim is to minimise mechanical vibration of magnets.**



Vacuum system: key features

- Vacuum chamber mostly consists of straight cylindrical tube.
 - **Internal diameter 63 mm, wall thickness 2 mm.**
- Antechamber and cooling provided in dipoles.
 - **Intended to reduce build-up of electron cloud by reducing the number of photons in the main chamber.**
 - **Dipole chamber will consist of extruded vessel with antechamber, welded to machined "taper" sections.**
 - **A pumping port is included in antechamber downstream of dipole.**

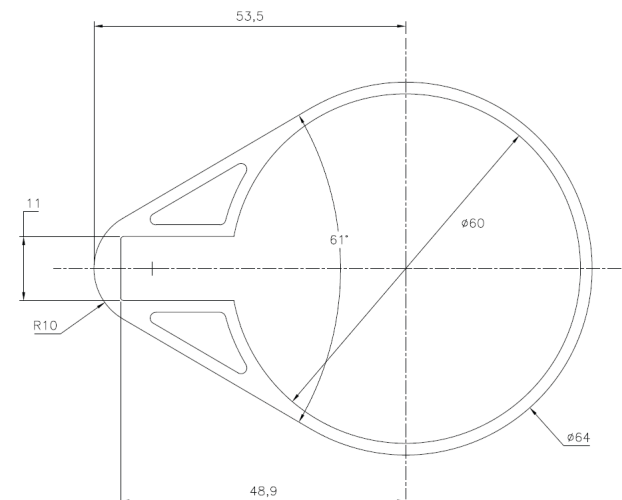
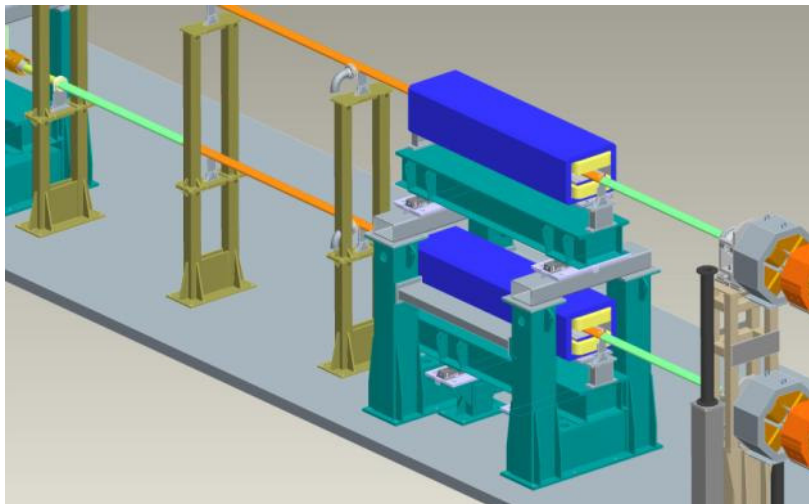



Vacuum system: key features

- BPM vessel will be independently supported.
 - **BPM is *not* fixed to any magnets.**
- Internal diameter of BPM housing is larger (by 2 mm) than ID of vessels on either side, to shield BPM buttons from synchrotron radiation.
- Bellows provide isolation from mechanical vibration in adjoining vessels.
- Linear encoders on adjoining "reference pillars" monitor any displacement of the BPM vessel (see next slide...)
 - **Based on the systems used at DIAMOND and SLS.**

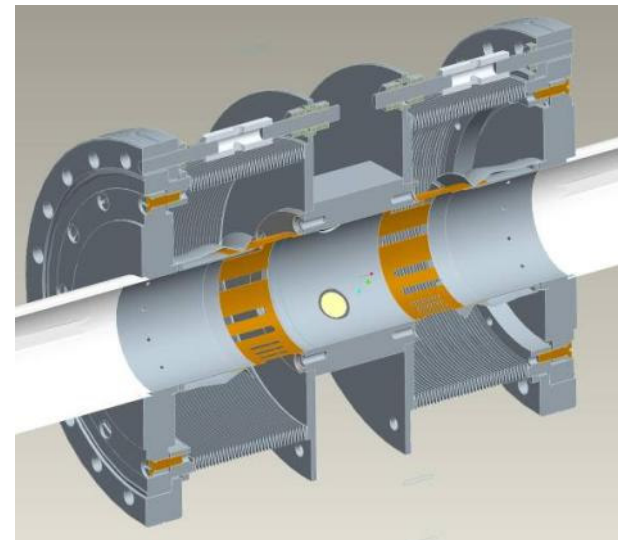
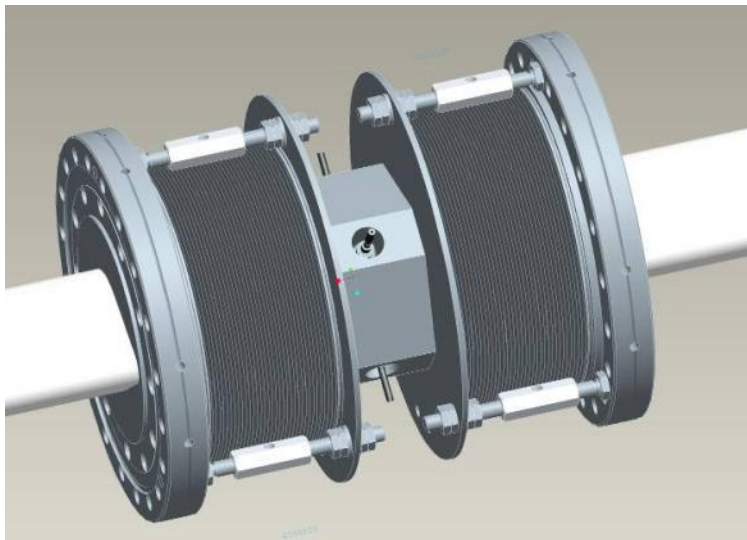



DIAMOND Light Source BPMs

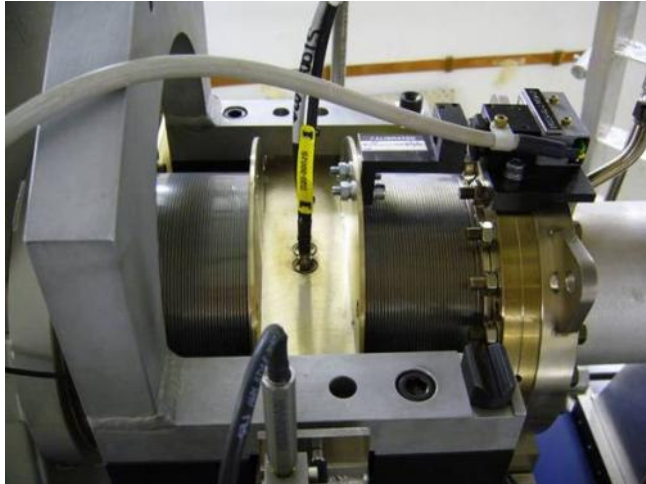

BPM and bellows chamber

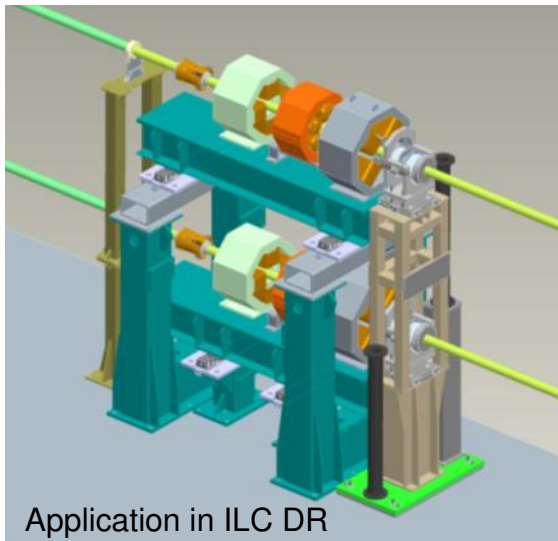

Application in ILC DR



Reference pillar supporting linear encoders

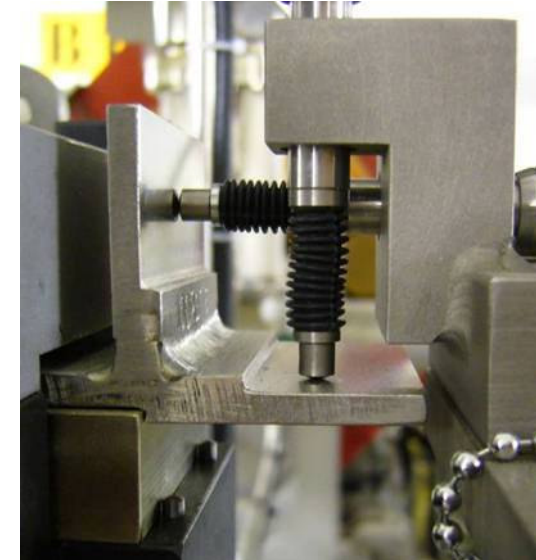

Linear encoders to monitor BPM position with respect to reference pillar



Design work in progress

1. Complete the present engineering model for the arc cell.
 - Address miscellaneous items (magnet stands...)
 - Allow for opposite beam directions in e^+ and e^- rings.
 - Include curvature in dipole, and perform ray tracing to evaluate synchrotron radiation power loads.
 - Optimise supports for magnets and vacuum chamber.
2. Provide technical designs of vacuum system components for beam dynamics studies.
 - Need to construct impedance model including BPMs, bellows, flanges, pumping ports, valves, tapers...
 - Need to model electron cloud build-up using latest codes.
 - Provide apertures information for magnet designs (impacts power requirements for damping rings...)
3. Make preliminary cost estimate of vacuum system, to identify cost drivers and to highlight areas for potential cost savings.
4. Commence design work for long straight sections.
 - Includes injection/extraction, wiggler, RF...



Ion-induced pressure instability

- NEG coating provides an effective technical solution for avoiding ion-induced pressure instability, allowing large spacing between ion pumps.
- Safety margin allows for lack of experimental data (ion desorption yields) in the parameter regime of the damping rings.

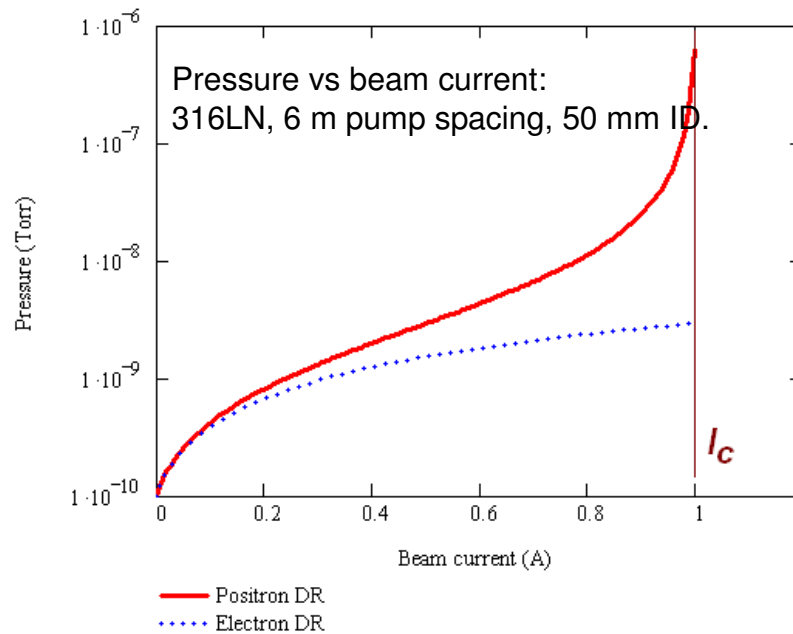

Vacuum chamber	I_c (A)	I_c/I_{max}	Dominant gas species	Stable or not
Distance between pumps L = 6 m, ID = 50 mm				
316LN	1.0	2.5	CO	Yes
Pure Al	0.5	1.25	CO	No
Ti alloy	1.1	2.8	CO	Yes
Distance between pumps L = 6 m, ID = 60 mm				
316LN	1.24	3.1	CO	Yes
Pure Al	0.64	1.6	CO	No
Ti alloy	1.4	3.5	CO	Yes
Distance between pumps L = 10 m, ID = 50 mm				
316LN	0.47	1.2	CO	No
Pure Al	0.24	0.6	CO	No
Ti alloy	0.53	1.3	CO	No
Distance between pumps L = 40 m, ID = 50 mm				
NEG coated	5	12.5	CH ₄	Yes

Oleg Malyshev (STFC/ASTeC).



Impedance modelling

- The goal is to develop an impedance model, including most of the major contributions from:
 - **BPMs, bellows, tapers, flanges, valves, pumps, rf cavities...**
- Where possible, the impedance model will be based on technical designs for the various components.
 - **The intention is to validate the model, and identify components that need an improved design to reduce impedance.**
- Presently, we are using HFSS to model the impedance.
 - **HFSS is a commercial code, working in the frequency domain.**
- The wake field is calculated from the impedance, then used in a one-dimensional tracking code to determine the instability thresholds.
 - **We approximate the wake function by a wake field calculated from an impedance extending to high frequency (compared to the frequency spread of the bunch spectrum.)**
 - **We also plan to use a Vlasov solver to determine the evolution of the longitudinal distribution.**



Impedance model: BPM + tapers

- The impedance was calculated for a BPM plus tapers on either side.
- Subsequently, modifications have been made to simplify the design of the vacuum system:
 - **One BPM in each cell has straight cylindrical tube on each side.**
 - **The other BPM in each cell has a straight cylindrical tube on one side, and a taper on the other side.**
- These modifications should also simplify the impedance calculation.

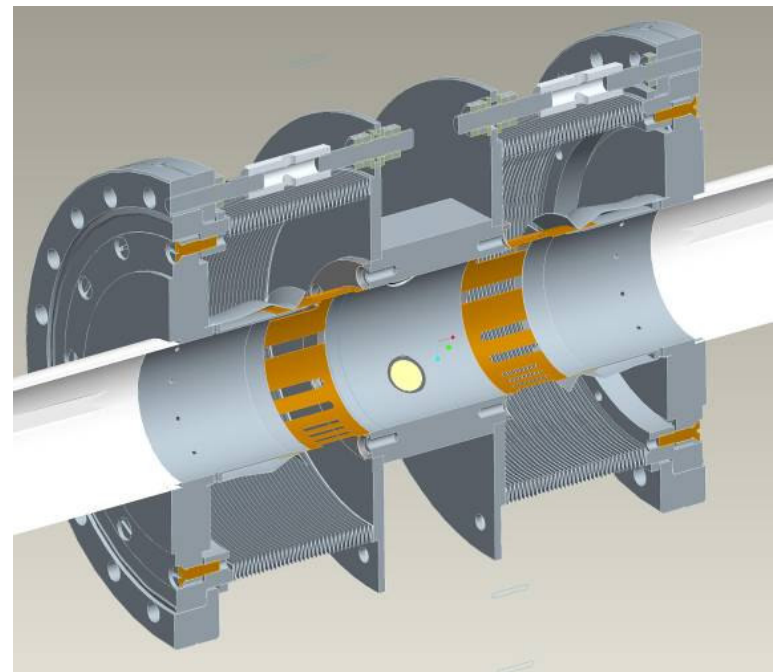
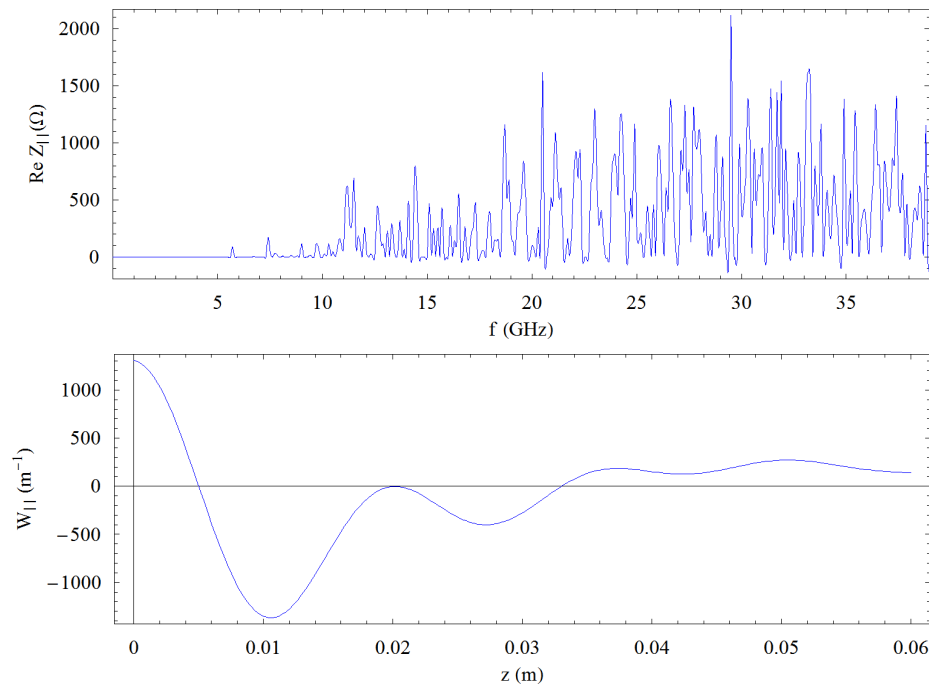



Loss factor and potential-well distortion

- The impedance can be used to estimate the power load from higher-order mode heating.
 - **For the nominal stored current (400 mA) and nominal bunch length (6 mm rms), the power load for a single BPM/taper section could be of order 1 kW.**
 - **We are in the process of calculating the impedance using modified technical designs, to identify the features of the design that make the major contributions to the impedance.**
- The wake function was used in a (one-dimensional) tracking code to estimate the effect of the BPM impedance on the equilibrium bunch distribution, as a function of bunch population.
- The results were compared with an estimate found by solving the Haissinski equation for the same wake function.
- Note: maximum specified operational bunch population is 2×10^{10} . Above a bunch population of $\sim 1.3 \times 10^{10}$, the Haissinski algorithm failed to converge.



Potential-well distortion

Bunch population 10^9

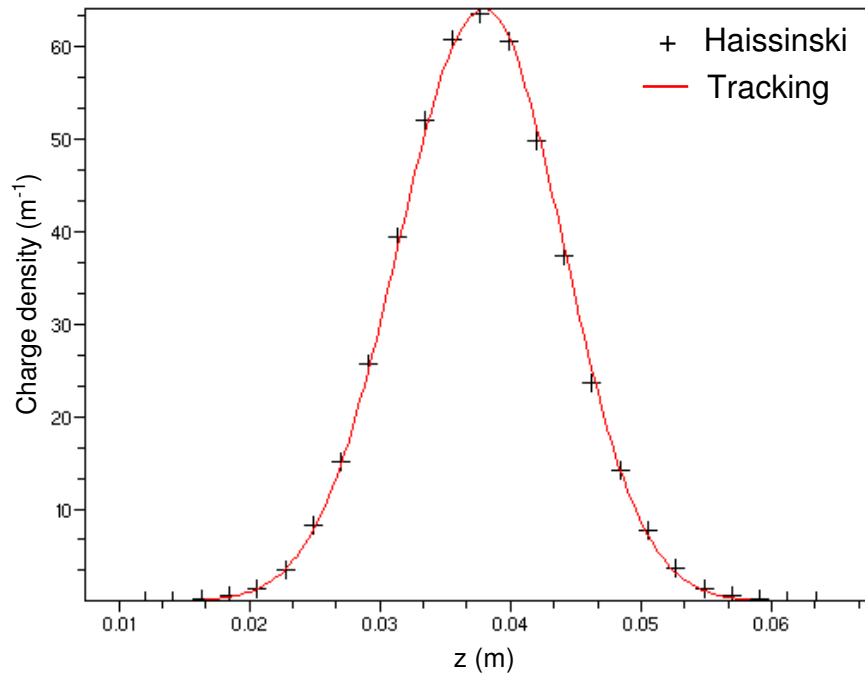

Bunch population 1.3×10^{10}

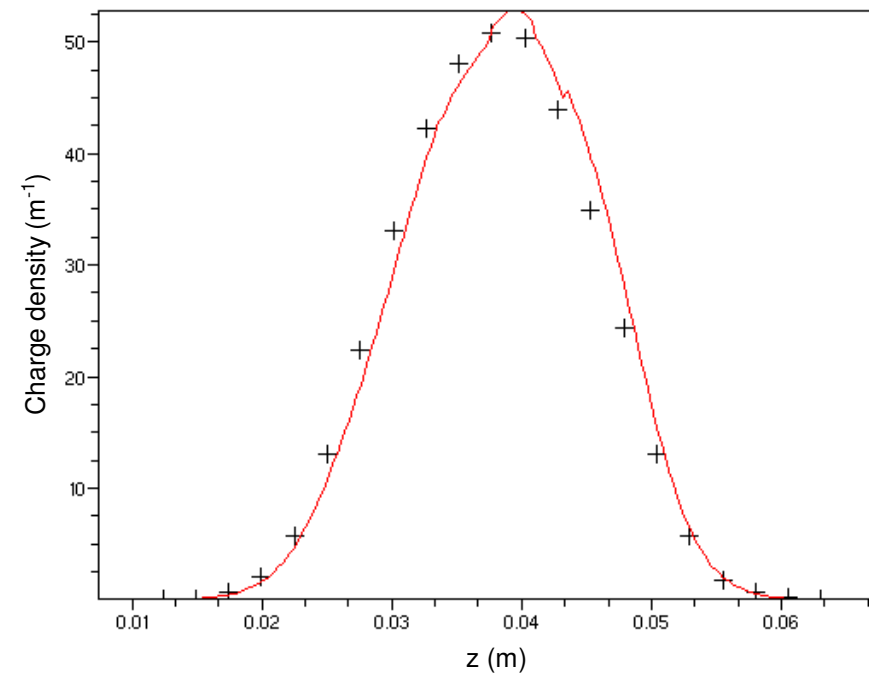



Longitudinal instability threshold

Averaging the rms energy spread over the final 300 turns of tracking gave an indication of an instability threshold at a bunch population of around 1.3×10^{10} . However, the energy spread grows fairly slowly with bunch charge above this threshold.

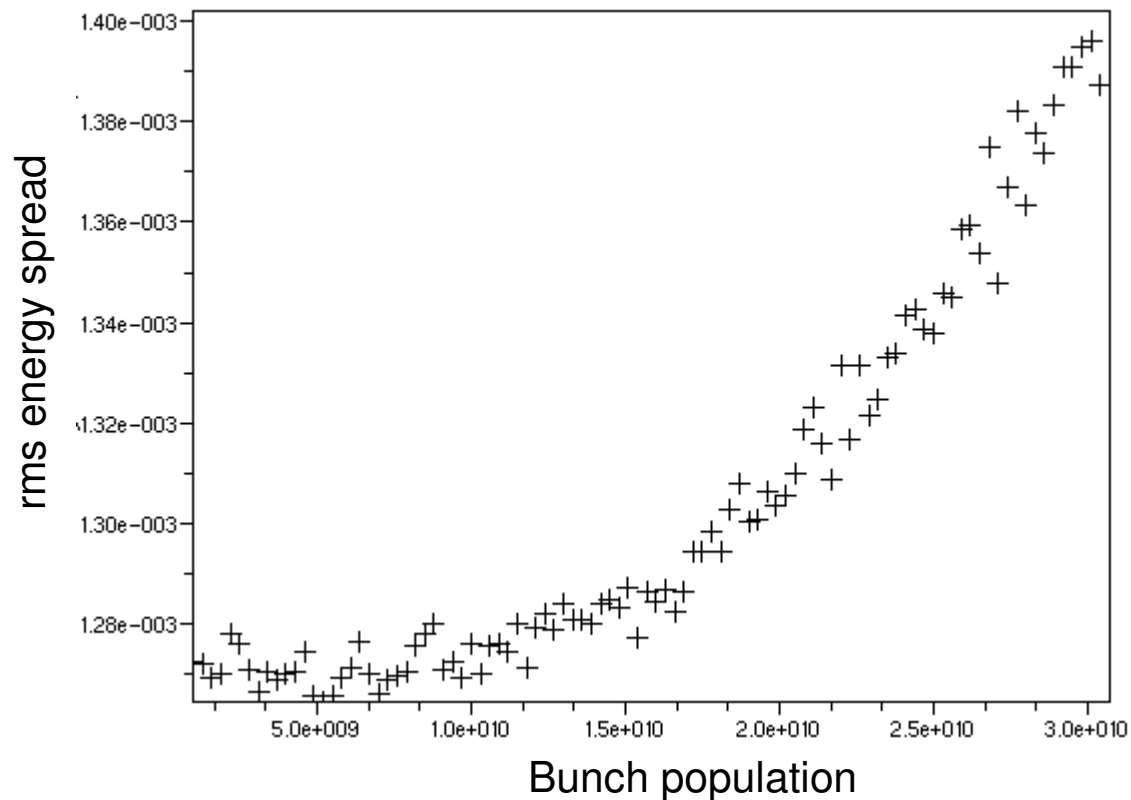



Impedance studies in progress

1. Improve accuracy of HFSS impedance calculation.
 - **Wake field does not completely vanish *ahead* of the bunch.**
 - **Accuracy should be improved by adapting mesh for different frequency ranges.**
 - **Techniques will be benchmarked against other codes (such as ABCI) in simple cases.**
 2. Perform impedance calculations for updated technical designs of vacuum system components.
 - **Identify design modifications needed to reduce impedance.**
 3. Update calculations of HOM heating, potential-well distortion, and instability thresholds using latest impedance models.
 4. Assess instability thresholds using tracking code, and benchmark using Vlasov solver.
- Note: low-emittance tuning studies also in progress should indicate number of BPMs actually needed (< two per arc cell).



Summary: engineering model and vacuum design

- Significant progress has been made with the vacuum system design and engineering model for the arc cells.
- The model will provide essential information required for further design work (magnets, conventional facilities...) and beam dynamics studies (including electron cloud and ion effects).
- The next steps are clearly defined in the present plan:
 1. **Complete the present engineering model for the arc cell.**
 2. **Provide technical designs of vacuum system components for beam dynamics studies.**
 3. **Make preliminary cost estimate of vacuum system, to identify cost drivers and to highlight areas for potential cost savings.**
 4. **Commence design work for long straight sections.**



Summary: impedance modelling

- Work is under way on impedance modelling.
- Impedance studies are linked closely with the work on the engineering model and vacuum design.
- Initial estimates have already indicated improvements needed in the designs of the BPM/taper sections in the arcs, to reduce impedance.
 - **There is the possibility of high HOM power loads, and instability threshold below the specified operating current.**
- Next steps are clearly defined in the present plan:
 - 1. Improve accuracy of HFSS impedance calculation.**
 - 2. Perform impedance calculations for updated technical designs of vacuum system components.**
 - 3. Update calculations of HOM heating, potential-well distortion, and instability thresholds using latest impedance models.**
 - 4. Assess instability thresholds using tracking code, and benchmark using Vlasov solver.**



The “minimal machine”

- The main concern at the moment is the impact of a possible change in the baseline configuration, associated with the “minimal machine”.
- An option being considered is to reduce the damping rings circumference from ~ 6 km to ~ 3 km.
 - **Initial peak luminosity would be reduced by a factor of 2.**
 - **Nominal average current, bunch charge, bunch length etc. in the damping rings would remain the same as at present: but number of bunches would be halved.**
- No “official” lattice design exists at present...
 - **...though we do have a 3 km lattice from the 2005 Configuration Studies.**
- Path to a decision on whether or not to change the baseline configuration is not yet completely defined.
 - **Discussions needed at ILC08 (Chicago, 16-20 November).**



DR Working Group Charge (1 & 2)

1. Review current status and schedule of CEsrTA, including simulation and experimental work for electron cloud characterisation/suppression and low-emittance tuning. Review the priorities of the various tasks, and update the plans for the future CEsrTA program.

2. Review ATF status and plans (4th Meeting of the ATF International Collaboration Board). Agenda:
 - Report of 5th and 6th ATF Technical Board Meetings (A. Wolski).
 - ATF Status Report (N. Terunuma).
 - ATF2 Status Report (T. Tauchi).
 - ICB Business (J.M. Paterson): recommendations for the activities and program at ATF/ATF2.



DR Working Group Charge (3)

3. Review recent progress with ILC damping rings R&D, particularly in regard to:

- critical risk-mitigating R&D, such as the fast injection/extraction kickers;
- machine design and cost reduction, including configuration issues related to the central injector (in joint discussion with CF&S and other related working groups).

Identify and prioritise future objectives and necessary resources.



DR Working Group Charge (4)

4. Prepare a plan for the remainder of the Technical Design Phase, including:
 - identification of goals to be achieved by the Accelerator Advisory Panel review in April 2009;
 - identification of studies needed to allow re-baselining of the ILC design by January 2010 (including studies of Minimum Machine options);
 - outline of studies to be completed (including specification of milestones and required resources) for the TD Phase 1 interim report, to be produced by July 2010.



DR Working Group Schedule

	8:30 – 10:00	10:30 – 12:00	13:30 – 15:30	16:00 – 18:00
Monday	CesrTA			Low-Emittance Tuning
	Status, Schedule and Recent Results	Electron Cloud Simulations	Electron Cloud Experimental Planning	
Tuesday	ATF International Collaboration Board 4	ILC Damping Rings R&D Updates and Discussions	Central Injector Layout (joint with CF&S and other WG)	
Wednesday	ILC Damping Rings R&D Updates and Discussions			Planning for the TDP (including Minimum Machine)



Contributions

- We welcome contributions on all aspects of the damping rings program:
 - **CesrTA**
 - **ATF**
 - **General damping rings R&D, including ILC and CLIC.**
- Please contact the conveners if you would like to make a presentation, or if you have any suggestions or comments on the program.